

# NAVAL ORDNANCE AND GUNNERY

## VOLUME 1 NAVAL ORDNANCE

Prepared by the Department of Ordnance and Gunnery  
United States Naval Academy · Edited and produced by the  
U. S. Navy Training Publications Center, under direction  
of the Bureau of Naval Personnel

# Part 1

NavPers 10797-A

UNITED STATES GOVERNMENT PRINTING OFFICE

WASHINGTON: 1957

This 1957 Edition is Revised From the 1955 Edition

---

For sale by the Superintendent of Documents, U. S. Government Printing Office

Washington 25, D. C. --- Price \$1.75

## PREFACE VOLUME 1

*Naval Ordnance and Gunnery* (1957) is a basic textbook on the subject of naval weapons and their control. Prepared for use primarily as a classroom text for midshipmen at the United States Naval Academy and in the Naval Reserve Officers Training Corps, it will also serve to support other officer and officer candidate training programs and will have general use as a reference book.

The text is limited to a treatment of fundamental concepts and principles of ordnance, with enough data on typical weapons and control systems for the purposes of the training programs for which it is intended. It is not intended to replace technical and doctrine publications of the Bureau of Ordnance and the Office of the Chief of Naval Operations.

The present edition is a revision of *Naval Ordnance and Gunnery* (1955). The present edition is issued in three volumes: 1, *Naval Ordnance*; 2, *Naval Fire Control and Gunnery Organization*, and 3, *Confidential Supplement*. These are all subtitles, appearing in conjunction with the general title, *Naval Ordnance and Gunnery*.

Revision of this publication, including the addition of new material, was accomplished by officers attached to the Department of Ordnance and Gunnery, U. S. Naval Academy, working in conjunction with the Training Division, Bureau of Naval Personnel, and the U. S. Navy Training Publications Center, Washington, D. C.

# CONTENTS

	<i>Page</i>		<i>Page</i>
Historical foreword.....	vii	<b>Chapter 8—Semiautomatic weapons</b>	
<b>Chapter 1—Introduction to ordnance and gunnery</b>		A. General.....	158
A. General.....	1	B. Five-inch 38-caliber assemblies.....	158
B. Scope of the text.....	3	C. Five-inch 54-caliber assembly.....	189
<b>Chapter 2—Explosives</b>		<b>Chapter 9—Automatic weapons</b>	
A. Introduction.....	7	A. Introduction.....	192
B. Explosive reactions.....	7	B. 20-mm aircraft gun.....	192
C. Service explosives: propellants.....	11	C. 40-mm guns and mounts.....	198
D. Service high explosives and primary explosives.....	15	D. 3"/50 rapid-fire guns and mounts.....	201
<b>Chapter 3—Ammunition</b>		<b>Chapter 10—Automatic control equipment</b>	
A. General.....	18	A. Introduction.....	214
B. Propelling charge.....	20	B. Synchros.....	215
C. Primers.....	25	C. Electric-hydraulic systems.....	222
D. Projectiles.....	28	D. Amplidyne follow-up system.....	231
E. Fuzes and tracers.....	33	E. Other types.....	235
F. Bombs.....	38	F. Shipboard tests of automatic control equipment.....	239
<b>Chapter 4—Armor and penetration</b>		<b>Chapter 11—Rockets and guided missiles</b>	
A. Types of armor.....	41	A. Rockets and the rocket principle.....	242
B. Penetration.....	44	B. Rockets fired from surface craft.....	249
<b>Chapter 5—Elements of guns and mounts</b>		C. Aircraft rockets.....	296
A. Introduction.....	46	D. Guided missiles.....	259
B. Features of modern naval guns and mounts.....	46	<b>Chapter 12—Torpedoes</b>	
C. Conclusion.....	80	A. Introduction.....	271
<b>Chapter 6—Gun barrels and interior ballistics</b>		B. Head section of a Mark 15 type torpedo.....	274
A. Introduction.....	82	C. Air system of a Mark 15 torpedo.....	277
B. Elements of gun design and maintenance.....	82	D. Superheating system of a Mark 15 torpedo.....	291
C. Interior ballistics.....	89	E. Main engine of a Mark 15 torpedo.....	294
D. Erosion.....	92	F. Control systems of a Mark 15 torpedo.....	300
E. New developments in gun design.....	94	G. Tail section of a Mark 15 torpedo.....	307
<b>Chapter 7—Turret installations</b>		H. Aircraft torpedoes.....	310
A. Introduction.....	97	I. Other types of torpedoes.....	312
B. Gun and breech assembly.....	99	J. Above-water torpedo tubes.....	314
C. Slide assembly.....	109	<b>Chapter 13—Mines</b>	
D. Elevating, training, and sight gear.....	110	A. General.....	317
E. Ammunition handling.....	113	B. Aircraft mines.....	323
F. Turrets equipped with case guns.....	121	C. Mine warfare.....	324
G. 6"/47 dual-purpose gun and turret.....	123		
H. 8"/55 rapid-fire gun and turret.....	137		

# CONTENTS

	<i>Page</i>		<i>Page</i>
<b>Chapter 14—Antisubmarine weapons</b>		<b>Appendix A</b>	
A. Antisubmarine warfare.....	327	Safety precautions.....	348
B. Depth charges.....	328	<b>Appendix B</b>	
C. Depth bombs.....	333	Velocity-loss data curves (5"/38 gun)....	354
D. Throwing weapons.....	335	<b>Index</b> .....	360
E. Nets and booms.....	343		

# HISTORICAL FOREWORD

## Introduction

The usefulness of a Navy rests primarily upon the fact that it can use offensive and defensive weapons effectively at sea. Ships of the Navy are often referred to as floating gun platforms. This definition is too limited, as the experience of World War II indicates that ships are equally effective in carrying and employing torpedoes, mines, depth charges, rockets, and guided missiles, as well as airplanes, which with their weapons greatly extend the fighting range of the ship. The importance of weapons to the Navy is indicated by the fact that most line officers serve at least one tour of duty in a gunnery department and that much of the professional training of line Naval officers is occupied with the study of ordnance and gunnery.

The detailed story of the development of weapons from the caveman's club to the guided missile of today is beyond the scope of the present book, but, for the purpose of establishing perspective, a brief review of some of the most significant steps is presented here and in certain of the later chapters, as appropriate.

## Ancient weapons

Although man, compared to most animals, is a fairly large and powerful creature, he is weakly armed in proportion to his size. He lacks not only horns and claws, but even the big canine tusks owned by his cousins the apes. A million years ago, when he began his climb towards civilization, he probably knew how to throw stones and to hit with a stick. All his many weapons developed since have had the same purpose; to kill, wound, or otherwise subdue his enemy. These weapons enable the warrior to attack his opponent at a greater distance than if he had to depend on hands and teeth alone, and, storing energy which is released all at once when the weapon strikes, to damage the victim more severely than is possible by biting and kicking.

The bow, invented at the beginning of the Neolithic Age, fulfilled both these functions. Before that time men used a device called a spear-thrower, a stick with a hook or spur at the end. They held the spear-thrower in the same hand that held the javelin or throwing-spear, with the hook of the thrower engaging a hollow in the butt of the javelin. Then they threw with an overhand motion, letting go the javelin

so that the thrower acted as an extension of the arm. The bow, having much greater range and accuracy, spread over most of the world and drove out the spear-thrower except among a few isolated tribes. A few peoples developed more specialized missile weapons, such as the boomerang, the sling, the pellet-bow, and the blow-gun. The natives of Borneo not only make a blow-gun for shooting poisoned darts, but also equip it with a sight and a bayonet.

The discovery of metals about 6,000 years ago brought about a revolution in weapons, since they could be made of copper or bronze more quickly than of stone, and since the material allowed a greater variety of forms. For instance, swords became practical for the first time though some peoples had previously tried to make them by edging a flattened wooden club with sharpened stones or sharks' teeth.

A typical bronze-age battle comprised a few well-armed nobles on each side, each protected by a helmet and a big leather shield, poking at one another with bronze-pointed spears, while behind them howling mobs of the common people hurled stones and insults. The nobles' swords of bronze or (later) of iron were so soft that after a bit of hard fighting, the swordsman had to take time out to straighten the kinks out of his weapon.

As metallurgy improved, not only did the quality of the weapons improve, but also more men could afford armor. Thus began the long conflict between armor and armor-piercing weapons that has continued ever since. When King Darius of Persia sent an amphibious expedition against Greece in 490 B. C., the Greeks beat the Persians at Marathon, not because they were braver, but because they had good bronze armor. The unarmored Persian archers had always been able to mow down their enemies from a distance; now, however, their arrows merely bounced off the helmets and breastplates of the Greek soldiers, and when the latter got in among them with spears there was nothing for the Persians to do but run.

Although nowadays science and invention are closely connected, this was not so in former times. Science was the vague speculations of priests and philosophers, while practical inventions were created slowly and under great handicaps by unknown common men. Moreover, most societies were very conservative about new ideas, so that brilliant inventions were often not adopted because of inertia, ignorance,

or distrust, or because they might impair somebody's vested interest.

For instance, the ordnance department, a group charged with improving weapons and devising new ones, was invented as early as 400 B. C., but failed to become an established institution until modern times. At that time Dionysios, the dictator of Syracuse, was planning to attack the Carthaginian colonies in Sicily. He therefore hired philosophers and skilled artisans at high wages, entertained them with wine, women, and song, and told them to devise something to beat the Carthaginians, or else. The experts accordingly invented the first catapult—a kind of overgrown crossbow on a pedestal, shooting 6-foot arrows. After the war one of these arrows was taken to Sparta as a curio, where a certain Archidamus, seeing it, cried: "O Heracles, the valor of man is at an end!" That is the first recorded protest against the mechanization of warfare.

Although such outcries have been heard with increasing frequency ever since Archidamus' time, they have done little to retard the evolution of weapons. When the crossbow came into general use in medieval Europe it was considered such a fiendish weapon that in 1139 the Catholic Church issued an edict against it, but with little effect. Similarly, objections have been raised more recently against submarine warfare, gas, and the atomic bomb.

#### Transition to modern weapons

In the Classical or Greco-Roman Age warfare reached an extraordinarily high degree of organization, with phalanxes of 20,000 spearmen, archers and slingers, war-elephants, armored siege-towers, catapults, incendiary bombs, and warships with crews of a thousand men or more. After the fall of the Roman Empire in the 5th and 6th centuries, the art of war declined in Europe almost to the howling mob stage out of which classical warfare had grown. For several centuries really skilled warfare was found only in the Byzantine Empire, that revived eastern half of the Roman Empire in Asia Minor and the Balkans. This superior military skill enabled the Byzantines century after century to roll back waves of Huns, Arabs, Russians, and other invaders before they finally went down before the combined attacks of Turks, Slavs, and Western European Crusaders.

The 4 or 5 centuries from the fall of the West Roman Empire to the rise of Western European civilization, though known as the Dark Ages because of its political disorganization and general illiteracy, witnessed a number of important inventions such as the wheeled clock, the iron horseshoe, and the rudder. In the 13th and 14th centuries appeared two of the most important inventions in the history of warfare:

the iron-casting furnace and the gun. Until the 13th century all iron was wrought iron, with a low carbon content and hence too high a melting point to be cast with the types of furnace available.

#### Gunpowder and early guns

Near the middle of the 13th century, Friar Roger Bacon gave the western world its first useful formula for gunpowder. This formula, which probably came from the Chinese by way of some Arabian manuscript, was followed by the discovery of the principle of the gun, a weapon which revolutionized the art of war.

Early books on gunnery attribute the discovery of the principle of the gun to Friar Bertholdus, nicknamed "The Black," of Freiburg, Germany. The friar was trying to turn mercury into gold, according to report, when he put a quantity of saltpeter in his mixture. The resulting explosion blew the top off his kettle, and probably some of the overhead with it. He repeated the experiment often enough to get the idea of the gun.

Early guns were crude and unpredictable, often more dangerous to the gunner than to the enemy. For a long time after the invention of the gun, many persons argued quite sensibly that bows were more efficient. They probably were. The crossbow bolt could penetrate the knight's armor; the early gun couldn't. The archer with the long bow could shoot several times while the gunner was loading and firing a single round.

The ballistics of early guns, which fired stone projectiles, was largely a matter of guesswork and observation. Powder was mixed on the spot by the gunner; artisans fashioned projectiles from local materials; and the mount was built at whatever spot it was needed. The only part of the gun carried on early campaigns was the barrel.

The ineffectiveness of the early guns is indicated by a record of an attack on a European town which says, "A knight besieged the town and fired at it with thunder guns. It did no harm."

The noise, the smoke, and the flame of the guns undoubtedly had a disastrous effect on the enemy. The horses were gun-shy, as a matter of record. An eyewitness to the battle of Crecy in the 14th century spoke with enthusiasm about the performance of "divers wooden and leathern tubes, called bombard, which with a great flash of light and a noise like God his thunder, threw little iron balls to frighten the horses."

Stone projectiles were replaced by bronze balls early in the 14th century, and these in turn were supplanted by lead or iron balls by the middle of that century. The mortar, which hurled a projectile a short distance on a high trajectory over hills or walls, was invented

by 1354. The mortar required less powder, was less likely to burst, and required fewer horses to transport it.

Canister shot, which later won battles for Napoleon, was first used about 1400. Balls, bottles, knives, and random items of small hardware were put in a container and fired from a gun. The container opened in flight and sprayed exposed parts of the enemy's anatomy with considerable effectiveness. Grape shot, also an antipersonnel weapon, was a later development. The first exploding shell was used prior to 1418, but this type of projectile did not become popular until the reign of Henry VIII of England. Heated shot was used at Cherbourg in 1418.

Although guns appeared on ships for the first time in the 15th century, firepower had been a factor in naval battles since well before the Christian era. The tactics were to maneuver a galley close to the enemy and attempt to ram him, overturn him, board him by means of grappling hooks, or shave off his oars by a close run. An alternate procedure was to catapult flaming sulphur, pitch, niter, or petroleum on the enemy ship, row away, and watch the fire. The first recorded naval use of a tube containing gunpowder which, when ignited, shot out a projectile occurred in 1453, when the Spanish opened fire with cannons and arquebuses at point-blank range on the Moslem fleet at Preveza. The Turkish fleet fell apart. Although such incidents awakened the slowest thinkers to the importance of naval gunnery, the pike, the cutlass, and the grappling hook were not to become obsolete until the 20th century.

The battle of Pavia in the early 16th century further proved the usefulness of guns as weapons of war. The Spanish put a few "firebearing" troops among their pikemen and proved to the French that a knight's armor was no longer a protection. The usefulness of the gun was evident. The French equipped their troops with arquebuses and returned to defeat the Spanish at Serisoles in 1544. Victory favored the army with the most effective combination of guns and other weapons. Two and a half centuries later, Napoleon could say "Le feu est tout." ("[Gun] fire is everything.")

Henry VIII of England was the first ordnanceman. The number of different sizes and kinds of guns in use in his army and navy annoyed the good monarch to the extent that he issued an "ordnance" which catalogued and attempted to standardize the types used. The title of this directive, corrupted to "ordnance," is the modern term that includes weapons of all types, ammunition, and associated equipment.

The Flemings had an international monopoly in the munitions business in the time of "Good King Hal." Coming from one of Europe's habitual battlegrounds,

they turned early to the manufacture of ordnance and were artists by Henry's time. Every king who wanted a good gunnery department imported gunners from Flanders at the gunners' own prices.

The Flemings formed a guild of "master gonners," who jealously guarded the secrets of gunnery and sold their services to the highest bidder. Henry's "gonners" wore billowing pantaloons and hats with flowing plumes, and were a swashbuckling, proud, and clan-ish lot.

These "gonners" earned their pay and prestige; they lived a dangerous life. An early book on gunnery opened with the maxim, "A gonner must love and serve God." The wick fuses they used burned "as long as it taketh to recite the Apostles' Creed."

The guns most used at the time were the culverin and the demiculverin. A later version of these guns pounded the Spanish Armada into the sea before the Spanish could get within their own battle range.

The early land version of the culverin weighed 4,000 pounds and required 16 teams of horses to move it. The sea-going demiculverin weighed 3,600 pounds and could shoot 1,950 yards, although its effective battle range (point-blank) was about 80 yards. The muzzle velocity of these guns was on the order of 500 foot-seconds, whereas our modern big guns launch projectiles at about 2,500 feet a second. The demiculverin took a 4½-inch iron shot, and the tube was 10½ feet long.

Loading the big guns was at best a dangerous operation, especially when "bombes" or fused projectiles were used. To get the picture of an early operating condition let us rephrase an old manuscript to reproduce an Ordnance Pamphlet as Henry's "gonners" might have written it:

"To charge ye peece of ordnance Gonner-like, set ye barrel of powdre on ye windward side of ye peece, have ye helper hold ye same at an angle and thrust ye Ladle into ye powdre, filling it half full. Fixing ye thumbe just over ye staffe of ye ladle, thrust it into ye muzzle of ye peece, causing ye powdre to turn out of ye Ladle cleanly. Shake ye Ladle thrice, so that no powdre returne in it—for that be a foule faulte in a good gonner; then thrust ye powdre home with ye tampion on ye other end of ye staffe. Have ye helper holde his thumbe over ye touch-hole whilst tamping. Then taking a rounde wadde of hay or raveled rope, thrust it on top of ye powdre, again tamping home. Then place ye shoote atop of ye wadde."

The gunner was warned to stand to one side when he loaded a gun, lest stray sparks from a previous loading ignite the powder and "spoil" him. Soaping out the gun solved the problem of stray sparks, but added further steps to the loading operation.

Firing the gun was even more dangerous. Resuming our Ordnance Pamphlet:

"In giving fire to any great peece of Ordnance, such as Cannon, Culverin, or such like, it is requisite that ye Gonner thereto appointed first see that ye peece be well primed, laying a little powdre about ye touch-hole as a traine, and then to be nimble in giving fire, which as soon as he espieth to flame, he ought with quicknesse to retire back three or four yardes out of danger of the reverse of ye wheels and carriage of ye peece; for oftentimes it happeneth that the wheels or axle-tree doth break and spoile ye Gonner that giveth fire, not having ability to move himself from the danger of ye same; yea, I did see a Gonner slaine with the reverse of the wheele of a culverin, which crushed his legge and thigh in peeces, who, if he had had a care, and nimbleness withal, might have escaped ye misfortune. Also, if ye burning powdre be dankish, or ye cole of ye matche not cleare, ye Gonner can not speedily give fire; and therefore behooveth he fore-see it; or if he hold ye linstocke in which his fired matche is tied long over ye touch-hole, ye violent flame issuing thereout is liable to spoile him, or some thereof, throwing ye linstocke or staffe wherewith he gives fire out of his hans. I have seen ye linstocke and matche blown out of a Gonner's hans more than 80 yardes from ye peece by ye violent blaste of ye fire issuing out of ye touch-hole of ye peece in giving fire to ye same. And it is to be noted, that ye wider ye touch-hole of ye peece, ye greater ye flame that doth issue out thereat, which causeth ye peece to work lesse effecte than she would having a lesser touch-hole."

Is there any wonder that the early gunner was cautioned to be a God-fearing man?

By modern standards, the "master gonner" didn't know much about the science of gunnery. Asked to explain what happened to the powder in firing, one expert of 1540 replied, "The powdre mixture, when burned, changeth into a strong wind." This theory was not improved upon from his day to the 19th century. It has been said that hardly a single Ordnance Pamphlet would be needed to fit one of Drake's men to serve aboard one of Nelson's ships.

The culverin and the demiculverin weren't the only big guns that the early gunner had to handle. An old report tells of a gun made by the Mohammedans from a Flemish design. The "Big Bombard," fired at Cairo, threw a 400-pound stone projectile more than two miles. The reporter adds, "By God, if I had not seen it myself, I should not have noted it in my history, so unbelievably unusual and great was it."

Early gunners were not military personnel, but served as civilian advisers, like our modern technicians. Gunnery officers were not given military rank in France until 1732, and in England they remained civilians until 1790.

Less than 200 years ago, naval guns were fired at point-blank range, and fire control was largely a matter of skillful seamanship. The captain of the ship had to maneuver his vessel within shouting distance of the enemy to make a hit probable. Range of early naval guns was spoken of as "pistol shot" and "half pistol shot." Not only were fire control devices nonexistent, but the dispersion of the guns was such as to make complicated sighting mechanisms useless. The development of fire control in the modern sense had to wait until the 19th and 20th centuries, when refinements in the manufacture of guns and a detailed study of the trajectory made possible accurate long-range shooting. Today it is possible to hit a moving target many miles away.

The foregoing pages give a brief description of some of the steps in the long history of the development from the primitive tools of the savage warrior to the complex technological developments used by the gunnery department of today. Many minds have played a part in this development. Discoveries in one branch of the science have necessitated furious research in other branches.

The greatest improvements in the gun itself have consisted of increases in range, accuracy, and destructive power. These improvements have been accompanied by development of fire control equipment and operational procedures.

War has been the major factor in the development of the science of gunnery. Every war necessitates not only the development of new weapons, but the improvement and adaptation to new uses of existing ones. World War I resulted in the development of accurate methods of surface fire; World War II perfected the vastly more difficult problem of antiaircraft fire control. Similar developments were made in mines, rockets, torpedoes, and bombs, as well as the unique device of the carrier-based airplane as an extension of the striking power of the ship.

Many interesting devices are on the Bureau of Ordnance drawing boards now, and some are ready for evaluation by the Fleet. If the science of ordnance and gunnery continues to develop at the pace of the last 50 years, we may well stand in as much awe of it in the near future as would one of Henry's "gonners" if he were ordered to man a modern fire control radar.

## Chapter 1

# INTRODUCTION TO ORDNANCE AND GUNNERY

## A. General

### 1A1. Definition of terms

This text is concerned with the study of Naval Ordnance and Gunnery. Together, the terms "ordnance" and "gunnery" embrace weapons and their use.

Ordnance comprises the physical equipment pertaining to weapons. This equipment is further classified as explosive ordnance, including such elements as gun ammunition, torpedoes, mines, bombs, rockets, and the like, and inert ordnance, which includes projecting devices (such as guns, launchers, and release gear), protective armor, and all the equipment needed to operate and control weapons. Aboard ship it refers to all elements that come under the general term "ship's armament."

Traditionally, gunnery is the art and science of using guns. However, in the sense used in this book, the term is broadened in agreement with modern usage, to include the operation and control of all elements of armament. Gunnery is concerned with the practical use of ordnance.

### 1A2. Navy Department responsibilities for ordnance and gunnery

Within the Navy Department, the responsibility for ordnance material rests chiefly in the Bureau of Ordnance. As defined by *Navy Regulations*, 1948:

"The Bureau of Ordnance shall be responsible for the following, except as otherwise prescribed in these regulations or by the Secretary of the Navy:

"The design, development, procurement, manufacture, distribution, maintenance, repair, alteration, and material effectiveness of naval ordnance; the research therein; and all pertinent functions relating thereto, including the control of storage and terminal facilities for, and the storage and issue of, ammunition and ammunition details."

The Bureau of Ordnance maintains field activities which contribute to the performance of its mission. These field activities include research activities, such

as the Naval Ordnance Laboratory and the Naval Proving Ground, inspection facilities, manufacturing plants, such as the Naval Powder Factory and the Naval Gun Factory, and various storage and distribution facilities.

The operational use of weapons is controlled by the Chief of Naval Operations through the fleet and force commanders, with appropriate liaison with the technical bureaus concerned. This control includes cognizance over operational and team training.

The Bureau of Ships and the Bureau of Aeronautics are concerned with the problems of design caused by the installation of ordnance on ships and aircraft, respectively, and their plans are coordinated with those of the Bureau of Ordnance in the satisfactory solution of these problems.

The Bureau of Naval Personnel is charged with the responsibilities for training both officers and enlisted personnel as individuals in the performance of their professional duties, except as otherwise assigned, and for the procurement, distribution, and record keeping of all personnel of the Navy. Training programs for all gunnery personnel, except aviation, are maintained by this Bureau.

### 1A3. Department of Defense responsibilities

In ordnance and gunnery, as in all other matters, the Navy functions not alone but as one member of a team. The Army and the Air Force both maintain ordnance establishments and both are interested in the art of gunnery. Ordnance equipment is usually developed by and procured by the service primarily interested. Doubtful or borderline cases are assigned to one service or another; for development work, by the Research and Development Board; for manufacture and procurement, by the Munitions Board.

There are hundreds of cases in which an item of ordnance equipment is used by all three services. For instance, the Navy and the Air Force both use Army rifles and pistols; the Air Force carries Navy mines, and

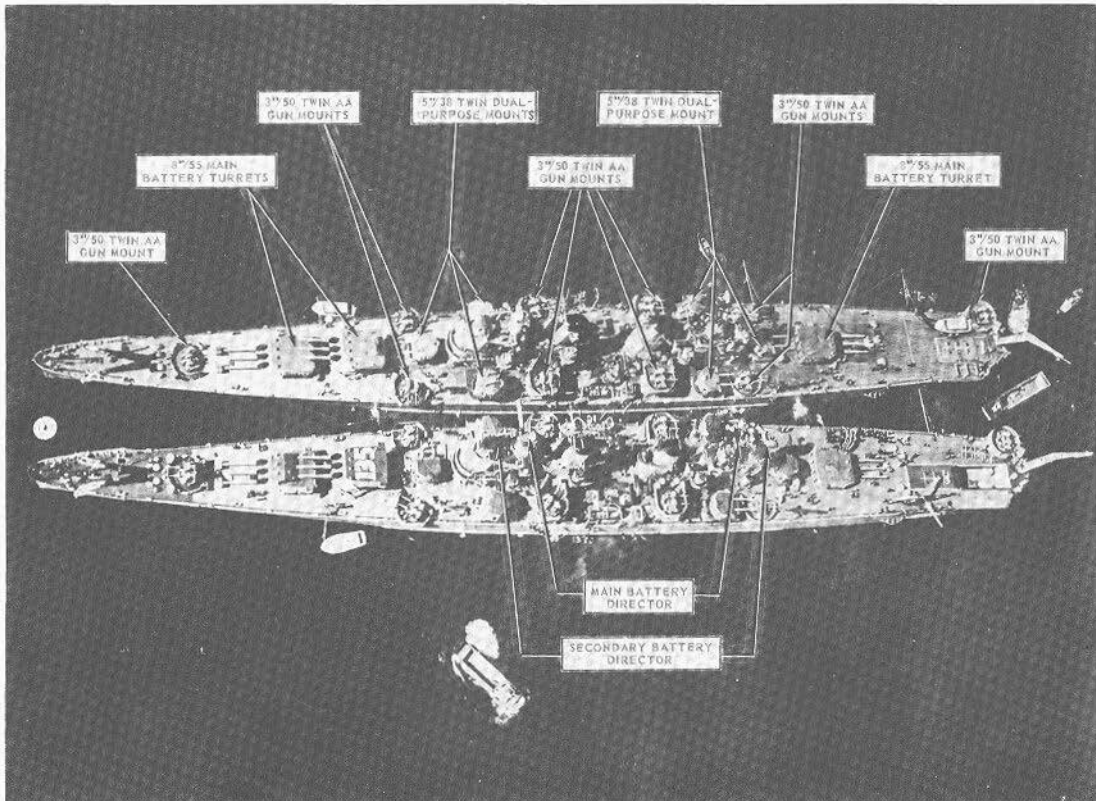

FIGURE 1B1.—Armament arrangement on a cruiser.

the Navy, Air Force bombs; the Army uses some Navy projectile fuzes, and the Navy, several Army rocket fuzes. When one service develops and procures a device for another, it usually furnishes all appropriate spare parts, tools, and instructional material as well.

Neither the Marine Corps nor the Coast Guard maintains ordnance departments. Each of these services has upon occasion developed and procured highly specialized equipment for itself; ordinarily, however, they are dependent for their ordnance upon the Army, Navy, and Air Force.

#### 1A4. Function of the gunnery department aboard ship

The requirements for battle are the basis for the organization of the combatant ship. Under *Navy Regulations*, 1948, in ships whose offensive charac-

teristics are primarily related to ordnance or aircraft, one of the major command departments is the gunnery department, headed by the gunnery officer. He is concerned primarily with the maintenance, upkeep, and operation of all the equipment in the ship's armament (with the exception of that of the ship's aircraft in ships having an air department). His department is organized into divisions, the number and function of which depend upon the class and purpose of the ship.

In auxiliary vessels, and certain other types whose offensive characteristics are not primarily related to ordnance and aircraft, gunnery is a secondary function of the deck department, which is headed by the first lieutenant. In this case such ordnance equipment as is carried is the responsibility of the first lieutenant, usually exercised through a gunnery officer who is one of his assistants.

## B. Scope of the Text

### 1B1. General

This text is planned to satisfy several needs. It is intended as a training text for midshipmen and officer candidates. It will be useful to gunnery department officer personnel as a reference and as a guide in the gunnery aspects of shipboard organization. And it is intended to serve as a convenient reference for all officers, other than those in the gunnery department, who have occasion to deal with any aspect of United States naval weapons—fiscal, supply, passive, defensive, etc.

This text is not intended to supersede or supplant official publications of the Chief of Naval Operations, the Bureau of Ordnance, or the Bureau of Naval Personnel with regard to doctrine, weapons and ammunition, shipboard organization, or shipboard operations. The reader is referred to official publications of these authorities for instructions on these matters. This text will, however, serve as an introductory guide to the official publications on these matters.

### 1B2. Presentation of the subject

It is difficult to present a clear understanding of the structure of ordnance mechanisms without some consideration of their operational use. Similarly, the successful study of gunnery depends upon a thorough understanding of the weapons and instruments used. In this book a compromise is effected: Volume 1 concentrates upon the study of weapons, with minimum reference to control, while volume 2 assumes knowledge of the first part and is concerned with fire control.

Emphasis has been placed upon functional operation of basic systems rather than upon the details of a wide

variety of individual instruments. This book was not written for the maintenance man or the repair technician. Ordnance Pamphlets are available for all equipment discussed in this text and should be consulted when more detailed information is required.

### 1B3. Naval weapons

The weapons to be discussed in the first part of the book include:

**Guns.** A gun typically consists of a tube, closed at one end, from which a projectile is fired by the burning in an enclosed space of a propellant charge. Guns are general-purpose weapons used against ships on the surface, aircraft, shore installations, and personnel.

**Rockets.** The rocket is a self-propelled weapon whose absence of recoil makes it particularly suitable for firing from small craft or aircraft.

**Guided missiles.** These are new weapons under current development. They may travel great distances with heavy loads, and self-propelled, and contain a mechanism capable of directing their own flight.

**Torpedoes.** A torpedo is a self-propelled underwater missile used against ships.

**Mines.** Mines are typically static weapons used to hinder enemy operations.

**Depth charges.** These are antisubmarine weapons which are exploded at a set depth or by proximity to a submarine.

**Bombs.** The term bombs covers all missiles dropped from aircraft except torpedoes, mines, and guided missiles.

**Chemicals.** This term is used to describe a variety of solids and gases which can be fired in projectiles

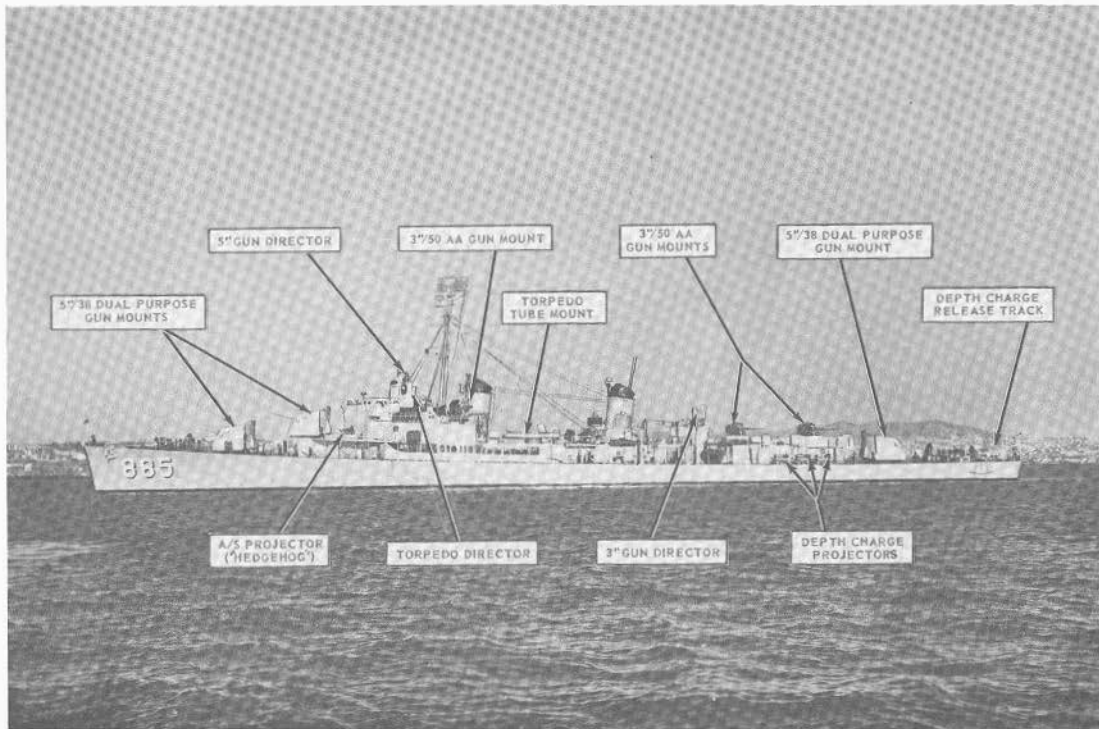

FIGURE 1B2.—Arrangement of weapons on a destroyer.

from guns or mortars or dropped from aircraft. In World War II they were used chiefly for screening and as incendiaries.

#### 1B4. Ballistics

Ballistics is the science of projectile motion. It falls naturally into two aspects; *interior* ballistics, which treats of the motion of the projectile within the bore of the gun, and *exterior* ballistics, which considers the action of the projectile in flight.

Each of these fields is the subject of careful and detailed study by specialists. Their findings are of enormous importance in gun design and in the development of fire-control instruments. A general understanding of ballistics is essential to the naval officer afloat, so that he may achieve the best results with his ordnance equipment.

#### 1B5. Fire control

The practical application of exterior ballistics, and the methods and devices used to control guns and other weapons are known as fire-control. The second part of the book treats of this subject in some detail, but a brief listing of some types of fire control equipment at this point may help the student form a better picture of the ordnance equipment found aboard most ships.

*Rangefinders.* Rangefinders are optical instruments used to measure the distance to the target.

*Radar.* Radar, using electronic means, provides more accurate ranges and, in addition, may measure bearing and elevation of the target.

*Directors.* Directors are mechanical and electrical instruments which control guns from a remote station. They are usually located at a higher level than the guns to provide greater range and better visibility.

*Rangekeepers and computers.* Rangekeepers and computers are mechanical and electrical, or electronic, instruments which automatically and continuously compute information needed to direct gunfire.

*Stable elements.* Stable elements are gyroscopically controlled mechanisms which measure movement of the ship with respect to the horizontal and compensate for the effect of this motion.

*Transmission systems.* Transmission systems are used to send information from one station to another; for example, to transmit gun orders automatically from the computer to the gun mount.

#### 1B6. Identification of ordnance equipment

Each assembled unit of ordnance equipment is identified by a name, a mark number, a modification number, and a serial number. This information is stamped either on the equipment itself or an attached plate. Whenever a basic change in design is made, a new mark number is assigned. Modification numbers

are added when a minor alteration of design has been made. Individual units of identical design have the same name, mark, and modification numbers, but have different serial numbers.

An example will help to illustrate the use of this identification system: Computer Mark 1 Mod 0 is the first computer designed. The Computer Mark 1 Mod 1 is similar to the Computer Mark 1 Mod 0, but differs in some details. Serial numbers are usually assigned on the basis of finished assemblies. The name of a gun includes its caliber, as 5-inch 38 caliber Gun Mark 12 Mod 1.

When the Navy uses items of Army ordnance, the Army nomenclature is retained. In Army nomenclature, **M** corresponds to Mark, **A** to Modification; for example, the Carbine M1A1.

In referring to a piece of ordnance, the information required for identification depends upon the circumstances. If reference is made to functions only, the name, mark, and modification will be sufficient. If, however, spare parts are being requested from the Bureau of Ordnance, the serial number may also be necessary.

#### 1B7. Knowledge of material

The operation of much ordnance equipment calls for detailed knowledge. Some details are included in this text, but the officer working with the gear should not be content with the coverage given here.

Shipboard installations can seldom be disassembled for the purpose of instruction, but a young officer should miss no opportunity to observe the disassembly of equipment for repair. At other times, he must study pamphlets, blueprints, ordnance circular letters, and other sources. He should not be satisfied until he is entirely familiar with the equipment assigned to his charge.

This information is essential to the gunnery division officer, not only because of his responsibility for the equipment itself, but also because he is responsible for the training of the enlisted men assigned to him for the operation and maintenance of the equipment. Without this knowledge, he will lack the necessary confidence, and his men will be quick to notice his deficiencies. Of course, much confidence can and must be placed in the senior petty officers, but this does not relieve the division officer of his responsibility.

#### 1B8. Care of material

The Bureau of Ordnance issues complete instruction for proper maintenance of ordnance material. These instructions should always be consulted and followed in detail.

All ordnance material is carefully manufactured, usually to close tolerances. Any careless treatment is likely to damage seriously a valuable piece of equipment, disabling it when it may be needed most. In using any fine apparatus, it is wise to be governed by common sense. The equipment was built to function. If it does not, something is wrong, and physical forcing will cause trouble. Levers, knobs, buttons, and switches should not be touched by a person who does not know what they will do. The *Bureau of Ordnance Manual* states:

"The permanent damage done in a single day of experimentation by inexperienced personnel has frequently exceeded that which, with proper care,

might be expected during the entire normal life of the material."

#### **1B9. Safety precautions**

Over a period of many years, various rules have been established to prevent casualty to personnel through carelessness or improper use of equipment. These rules are called Safety Precautions and are published by the Bureau of Ordnance, having the full force of regulations. They have been formulated through actual experience with ordnance, and are revised as needed.

Selected safety precautions are included in appendix A of this book.

## Chapter 2

# EXPLOSIVES

## A. Introduction

### 2A1. Fundamental ideas

The value of ordnance lies in its power to destroy. This depends on the use of explosives more than on any other factor. The gun projectile reaches the target because of the energy released by the propellant charge; it disrupts defenses and harasses enemy personnel primarily to the extent that the bursting charge it carries is effective. Mines and torpedoes tear holes in the steel skin of a ship because of the force released

by the great quantity of high explosives they contain.

One of the most important aspects of the history of ordnance is the development of explosives from the weak and unstable gunpowder of Roger Bacon to the highly specialized explosives of today. The latest discovery was nuclear fusion and its release of tremendous explosive energy.

The present chapter is confined to a discussion of the characteristics, use, and handling of chemical explosives currently used in the United States Navy.

## B. Explosive Reactions

### 2B1. Preliminary

Most people know that chemistry and physics are sciences which deal with *matter* and *energy*, and that matter and energy are closely related. Chemistry deals with the composition and changes in composition of substances, and a chemical change is a definite permanent change of certain properties, with the formation of new substances. Such changes are always accompanied by a gain or loss of energy. Whenever a chemical change takes place, there is a chemical reaction.

An explosion is one kind of a chemical change. It is a rapid and violent release of energy, produced by the rapid chemical decomposition and oxidation of any of several substances called *explosives*. It is true, of course, that the term explosion is often applied to violent releases of energy not involving explosive substances. In the explosion of a boiler, for example, the water (or steam) is not considered an explosive substance. But in this text, the term explosion is reserved to describe a chemical reaction that produces heat, and forms decomposition products, some or all of which are gases. An explosion is simply a rearrangement process, whether it is a rapid burning (as in some explosives) or a violent detonation (as in others).

Many modern explosives are based on chemical compounds containing nitrogen. Though nitrogen itself is chemically a relatively inert gas (it makes up

most of the atmosphere), its oxidized form combines with other elements to form (among other products) more or less unstable chemical compounds which explode violently in the sense of the word as used in this

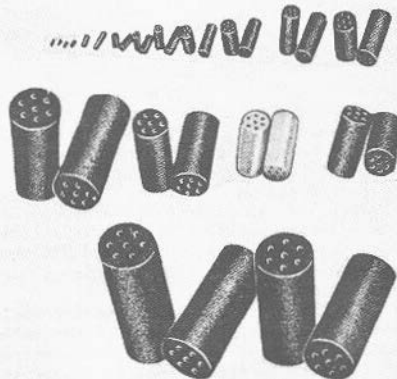

FIGURE 2B1.—Smokeless powder grains (caliber .30 to 16"/50); the two white grains are SPCG powder.

text. This violent explosion (or decomposition and rearrangement) liberates large amounts of heat and produces large volumes of gases, which expand and occupy a great deal more space than the explosive did originally. An explosive reaction, therefore, always produces a sudden rise in pressure because of the formation of gases and their expansion by the heat liberated in the reaction. The sound and shock waves associated with an explosion are caused by this sudden rise in pressure.

It will be seen later that the rise in pressure may be comparatively slow or it may be so fast as to be almost instantaneous. But whether an explosion is fast or slow, it is a decomposition and rearrangement of substances and is therefore basically a chemical reaction.

For a discussion of atomic explosives, see volume 2 of this course.

## 2B2. Classification of explosive substances by reaction

Explosive substances include a large number of chemical compounds and mixtures. The greater number of military explosives fall into the following groups.

1. *Explosive inorganic compounds.* Lead azide is an example. Lead azide is used as the detonator in major-caliber fuzes, because its relatively low sensitivity permits the projectile to penetrate armor plate before the detonator functions.

2. *Explosive organic compounds.* In this group are the main military explosives. It includes nitrated derivatives of the carbohydrates (example: nitrostarch), and the nitrated derivatives of aromatic compounds, such as trinitrotoluene (TNT). The prefix *nitro* appears in the chemical names of several modern explosives, such as *nitroglycerin*, *nitrocotton* (the main component of smokeless powder), *trinitrophenol* (picric acid), and others.

3. *Mixtures.* This group includes mixtures formed by oxidizable and oxidizing bodies, solid or liquid, neither of these being explosives separately. Black powder is an example.

With regard to their type of *reaction*, however, explosives are classified as *low* (sometimes called *burning* or *progressive*) and *high*. This speed of burning or breaking up is considered the most important characteristic of an explosive substance.

A *low* explosive reaction is a true burning, which proceeds from point to point throughout the explosive substance, accelerated by the heat and pressure produced. Since a low explosive burns, it builds up pressure comparatively slowly, delivering a powerful but controlled push to the projectile, following through all during the projectile's movement in the bore. Low explosives always contain a source of oxygen, and one

or more combustible elements such as carbon or hydrogen. Because the explosive itself contains all the oxygen required for the reaction, the combustion can proceed without support from outside sources. Among the well-known burning explosives are black powder, ballistite, United States Navy smokeless powder, and Cordite.

**NOTE:** The term "low explosive" is no longer recognized by specialists as a distinctive term denoting a class of explosives, since many explosives of this type can be made to react like high explosives under certain conditions. However, the term continues to be used in this text because the classification, though perhaps no longer accurate enough for the specialist, is still a useful concept for the student.

*High* explosives give rise to reactions that proceed almost instantaneously throughout the explosive mass. They produce their pressure (with a shattering effect) almost instantaneously, in what is called a detonation. If a high explosive were to be used for a propellant in a cartridge case, all its energy would be used in shattering the gun before the projectile had a chance to move. Combustible elements and oxygen are usually, but not always, present in high explosives. These substances are characterized by unstable molecules that include weakly attached parts such as nitrate and nitro groups. The initiating impulse brings about a breaking down of the chemical bonds, and a molecular rearrangement occurs so rapidly that the evolution of hot gases is almost simultaneous throughout the mass. Some examples of high explosives are: TNT, RDX, HBX, tetryl, and ammonium picrate.

*Primary* explosives, like high explosives, detonate when initiated, but they are extremely sensitive and, as a class, have less power, weight for weight, than high explosives. However, there is no abrupt, sharp dividing line between primary and high explosives. Primary explosives are used chiefly to initiate explosive trains. Primary explosives in current use in the Navy include lead azide, mercury fulminate, lead styphnate, diazodinitrophenol (DDNP), tetracene, and nitromannite.

## 2B3. Classification of explosive substances by composition

From the standpoint of their composition, explosives may be divided into *explosive mixtures* and *explosive compounds*.

Explosive mixtures are an intimate mixture of distinct substances, carefully prepared and mechanically conglomerated in varying proportions. Explosive mixtures must have some oxygen supplier such as nitrate or chlorate, and some combustible such as carbon or sulphur. Black powder is a typical example of an explosive mixture.

Explosive compounds are homogeneous substances whose molecules contain within themselves the oxygen, carbon, and hydrogen necessary for combustion. Whereas the characteristics of explosive mixtures can be varied by changing the proportions of the components, the elements constituting an explosive compound are always present in the molecules in the same proportions. Therefore, the nature of the explosive compound cannot be changed by varying the quantities of the constituent elements. Explosive compounds of different characteristics can be obtained, however, by nitrating the basic substance to different degrees. Explosive compounds consist very largely of organic compounds (hydrocarbons) into which nitric ( $-\text{NO}_2$  or  $-\text{O}-\text{NO}_2$ ) groups are introduced by the process of nitration. Examples of explosive compounds produced by nitration are cellulose nitrate, nitroglycerine, TNT, ammonium picrate, tetryl, and RDX.

#### 2B4. Characteristics of explosive reactions

The most important characteristics of explosive reactions are as follows:

1. *Velocity.* An explosive reaction differs from ordinary combustion in the velocity of the reaction. This is also the basis for differentiation between high and low explosives. The velocity of combustion of explosives may vary within rather wide limits, depending upon the kind of explosive substance and upon its physical state. The burning rate of colloidal cellulose nitrate powders used as propellants in modern guns is in the order of 24 centimeters per second at average gun pressures, whereas the velocity of reaction of high explosives ranges from about 2,000 to 8,500 meters per second.

2. *Heat.* An explosive reaction is always accompanied by the rapid liberation of heat. The amount of heat represents the energy of the explosive and hence its potentiality for doing work. It may be supposed that the quantity of heat given off by an explosive reaction is large, but this is not necessarily the case. A pound of coal, for example, yields five times as much heat as a pound of nitroglycerine. However, coal cannot be used as an explosive, because it fails to liberate heat with sufficient rapidity.

3. *Gases.* The principal gaseous products of the more common explosives are carbon dioxide, carbon monoxide, water vapor, nitrogen, nitrogen oxides, hydrogen, methane, and hydrogen cyanide. Some of these gases are suffocating; some are actively poisonous. The gases from low explosives are rarely dangerous, since they usually escape at once into the open and are dissipated and diluted with air. Generally speaking, the commonly used high explosives produce a large proportion of noxious gases, which are particularly

dangerous, since under normal conditions of use these gases do not dissipate rapidly. Projectiles filled with high explosives often burst after penetration into confined spaces from which the gases are not easily evacuated.

Some of the gaseous products of explosive reactions are themselves flammable, or form explosive compounds with air. Among these are hydrogen, carbon monoxide, and methane. The flame at the muzzle of a gun when it is fired results from the burning of these gases in air. Similarly, residues of the explosive mixture remaining in the gun, or blown back by adverse winds, have been known to ignite when brought into contact with air as the breech is opened. The ignition may come from the high temperature of the gas or from the burning residue in the gun bore. The resulting explosion may transmit flame to the rear of the gun, producing what is called a *flareback*. Flarebacks may ignite fresh powder charges being served to the gun. This danger has led to the adoption of gas-expelling devices on guns installed in enclosed compartments or mounts.

4. *Pressure.* The high pressure accompanying an explosive reaction is due to the formation of gases which are expanded by the heat liberated in the reaction. The work which the reaction is capable of performing depends upon the volume of the gases and the amount of heat liberated. The maximum pressure developed and the way in which the energy of the explosion is applied depend further upon the velocity of the reaction. When the reaction proceeds at a low velocity, the gases receive heat while being evolved, and the maximum pressure is attained comparatively late in the reaction. If, in the explosion of another substance, the same volume of gas is produced and the same amount of heat is liberated, but at a greater velocity, the maximum pressure will be reached sooner and will be quantitatively greater. However, disregarding heat losses, the work done will be equal. The rapidity with which an explosive develops its maximum pressure is a measure of the quality known as *brisance*. A *brisant explosive* is one in which the maximum pressure is attained so rapidly that the effect is to shatter material surrounding it or in contact with it.

#### 2B5. Sensitivity of explosive substances

The amount of energy necessary to initiate explosion is the measure of the sensitivity of the explosive. Sensitivity is an important consideration in selecting an explosive for a particular purpose. For example, the explosive in an armor-piercing projectile must be relatively insensitive; otherwise the shock of impact would detonate it before it had penetrated to the point desired. Again, if the molecular groups in the explosive

are in such unstable equilibrium that the reaction starts spontaneously, or in response to a slight blow, the substance can have no practical application whatever.

It was originally considered that the power of an explosive was measured by the sensitivity and that the most powerful explosives were the most sensitive. Investigation has proved that this is not true. TNT is a good example of a very powerful explosive which under ordinary circumstances requires a severe shock to initiate explosion.

## 2B6. Initiation of explosive reactions

An explosive reaction is initiated by the application of energy. The preferred method of initiation depends on the characteristics of the individual explosive. However, in accordance with the dual classification of explosives into *low* and *high*, the two methods of initiation commonly distinguished are:

1. *By heat.* Low explosives are commonly initiated by heat; and the resulting reaction is a burning process, which occurs on the exposed surfaces of the substance and progresses through the mass as each layer is consumed. Some high explosives will react when sufficient heat is applied, especially if heat is applied suddenly throughout the mass. Initiation by percussion (direct blow) or by friction is simply another form of initiation by heat derived from the energy of the blow or friction.

2. *By shock.* High explosives, such as the main charges of mines or torpedoes, in general require the sudden application of a strong shock or detonation to initiate the explosive reaction. This detonation is usually obtained by exploding a smaller charge of a more sensitive high explosive that is in contact with or in close proximity to the main charge. The smaller charge can readily be exploded by heat or shock.

It has frequently been demonstrated that detonation of an explosive mass can be transmitted to other masses of high explosive in the near vicinity, without actual contact. The second explosion occurring under these conditions is said to be initiated by *influence*, and it has been generally accepted that the initiating effect is the result of the passage of an explosive percussion wave from one mass to the other. The second explosion is called a *sympathetic explosion*. The distance through which this action may take place varies with the kinds of explosive, the intervening medium, and certain other conditions. The tremendous energy of the percussive wave in an underwater explosion is evidenced by the immediate upheaval of the water when the explosion occurs. The geyser-like eruption which occurs shortly afterwards is caused by the rise of the gases of the explosion to the surface.

## 2B7. The explosive train

Modern explosive devices, even of simple types, very rarely contain one explosive or explosive component only. They commonly apply the principle of chain reaction, in which a chain or train of elements functions in sequence. The first part of the train, called the *initiator*, *primer*, *cap*, or *detonator*, begins the action when set off by an electric current, shock, heat, friction, or some other stimulation. The heat or shock of explosion of this first part of the train sets off one or more succeeding parts in sequence. Depending on their functioning, these are called *ignition*, *booster*, or *auxiliary* charges. The final link in this intermediate sequence (which may consist of one or more such links) ignites or detonates the main (*burst*, *disrupter*, or *propellant*) charge.

There are two main types of explosive train, depending on the purpose and nature of the main charge. Propelling or impulse charges are low explosives intended to develop, through rapid burning, energy to be used for propulsion. An explosive train for a propelling charge generally begins with a primer which produces a hot flame. This sets off the ignition charge (composed of a flame-producing explosive—black powder). Last in the explosive train is the propellant powder or grain itself, which burns to produce the hot high-pressure gases which propel the gun projectile or rocket.

In the explosive train designed to detonate a high explosive, the sequence of operation in general depends on the transmission and amplification of shock rather than a hot flame. The initiating device contains a sensitive explosive which produces shock when set off; the initiating shock sets off the booster or a series of boosters or auxiliaries; the magnified shock detonates the main charge. The booster may be composed of the same explosive as the main charge, but in more sensitive form. Thus, granulated TNT, which is more sensitive than the cast variety, is used as a booster in depth charges.

## 2B8. Classification of explosives according to service use

Naval explosives may be classified according to the use to which they are put:

1. *Propellants and impulse explosives.* These explosives are used to propel projectiles from guns, to propel rockets, launch torpedoes, launch depth charges from projectors, and catapult aircraft. They are all *burning* or *low* explosives. Examples are smokeless powder, ballistite, Cordite, and black powder. Figure 2B1 shows smokeless powder grains of various sizes.

2. *Disrupting explosives.* Explosives of this classification are all employed to create damage to the target under attack. They are all of the *high* explosive

type and are used alone or as part of the explosive charge in mines, bombs, depth charges, and torpedo warheads, and in projectiles as a burster charge. There is a wide variety in this category, but the more common examples are RDX, TNT, ammonium picrate, and tetryl.

3. *Initiating (primary) explosives.* As explained in article 2B6, the initiation of an explosive reaction requires the application of energy in some form. Propellants are commonly ignited by the application of flame, while disrupting explosives are set off by a severe shock. Many primary explosives can be used for initiating either propellants or disrupting explosives, because they produce both a flame and a shock when exploded.

The device used to initiate the burning of a propellant explosive is called a *primer*. A simple primer consists of a small amount of lead azide and a small charge of black powder in a container. When fired, the primer produces the long, hot flame required to ignite the propellant.

## C. Service Explosives; Propellants

### 2C1. General

The primary function of a propellant is to provide pressure which, acting against the object to be propelled, will accelerate the object to the required velocity. This pressure must be so controlled that it will never exceed the strength of the container in which it is produced (e. g., guns, torpedo tubes, and depth charge projectors). The control of pressure produced by propellants and impulse charges is treated in considerable detail in the chapter on interior ballistics.

It would be possible to use any explosive for propellant purposes if the velocity of explosion could be controlled. Investigations of this problem led to the development of smokeless powder as we know it today. Nitrate cotton, the main constituent of smokeless powder, is a high explosive by itself and entirely unsuitable as a projectile propellant. However, it was discovered that this high explosive could be colloidized with an ether-alcohol mixture to produce a "burning" explosive. Only a small number of chemical compounds can be so treated as to permit control of the velocity of explosion. Furthermore, the substance in its final state must not only be efficient, but must be safe in use, easy to handle, and stable under varying conditions of storage for protracted periods of time.

Smokeless powders of one form or another are now used almost universally for propellant charges. For military purposes (especially for guns larger than small arms) they may be considered to be of two

The device used to initiate the reaction of a disrupting explosive is called a *detonator*, and in most cases it consists of a charge of lead azide or lead styphnate either alone or with granular TNT or tetryl in a container. When fired, the detonator produces the shock necessary to initiate the explosive reaction.

4. *Auxiliary explosives.* Large propellant charges and relatively insensitive disrupting explosives require an intermediate charge, so that the flame or shock of the initiating explosive may be increased to ensure proper reaction of the main explosive charge. The intermediate or auxiliary explosive used with propellants is called an *ignition charge* and consists of a quantity of flame-producing black powder sufficient to engulf the propellant grains. The auxiliary explosive used with disrupting explosives is called a *booster* and consists of a quantity of more sensitive high explosive, such as tetryl or granular TNT. The booster increases the shock of the detonator to a degree sufficient to explode the disruptive charge.

classes: (1) single-base powders, and (2) multi- (double or triple) base powders.

In the single-base powders, cellulose nitrates (referred to hereafter as nitrocellulose) form the only explosive ingredient. The other materials present in single-base powders are included to obtain suitable form, desired burning characteristics, and stability.

In the double- or triple-base powders, nitroglycerin is present to assist in dissolving the nitrocellulose during manufacture, as well as to add to the explosive qualities. The single-base nitrocellulose powders produce a greater volume of gas, but less heat than the double-base powders. From a thermodynamic standpoint, single-base nitrocellulose powders are somewhat less efficient, because of their lower burning temperatures. But they have the advantage of causing less wear in the gun bore than double-base powders do. Present triple-base powders, however, have a large proportion of the "cool"-burning explosive nitroguanidine; they therefore produce maximum temperatures comparable to those of single-base powders. Triple-base powders also have other advantages, which are mentioned in article 2C5.

### 2C2. Smokeless powder manufacture

The smokeless powder used by the United States Navy is a uniform ether-alcohol colloid of carefully purified nitrocellulose to which is added a small quantity of diphenylamine to assist in preserving the chemical stability of the powder. The principal raw

materials used in the manufacture of United States Navy smokeless powder are:

1. *Cotton.* The cellulose material to be nitrated consists of bleached and purified short-fibered cotton, which is 90 percent pure cellulose.

2. *Acids.* A mixture of about 1 part nitric acid to 3 of sulphuric acid by weight is used in the nitrating process.

3. *Ether and alcohol.* A mixture of ethyl ether and ethyl alcohol is used as a solvent for the nitrocellulose.

4. *Diphenylamine.* This substance, used as a stabilizer, has a slightly alkaline reaction and is incorporated in the powder to neutralize any acid products which might be formed as a result of gradual decomposition of the powder. Since it thus prevents decomposition from becoming progressive, it adds to the stability of the powder.

The principal steps in the manufacture of United States Navy smokeless powder are as follows:

1. *Preparing the cellulose.* The purified cotton is passed through picking machines which tear apart the knots and tangles, and then through driers which reduce the moisture content to about 1 percent, moisture being undesirable in the nitrating process.

2. *Nitrating.* The cotton and acids are thoroughly mixed and agitated in nitrators. The cotton is converted into nitrocellulose containing about 12.6 percent nitrogen. This is commonly called "pyro." After nitrating, the pyro and excess acids are sent to a centrifugal wringer below the nitrator, where the spent acids are removed.

3. *Purifying.* The pyro is immersed in water and run through flumes to boiling tubs where it is given a preliminary boiling for about 40 hours to remove the remaining free acids. It is then transferred to pulpers which cut and grind it to the desired consistency. The pyro is then boiled in water in poaching tubs for 12 hours, during which time the water is changed at regular intervals.

4. *Dehydrating.* After the final stage of purification in the poaching tubs, the pyro is transferred to the dewaterers (large rotary filters equipped with wet vacuum pumps) and to centrifugal wringers which remove water. The remainder of the water is forced out by placing the pyro in the cylinder of a hydraulic press and forcing alcohol under pressure through it. The pyro cake formed is subjected to a final pressure treatment to remove excess alcohol, leaving only sufficient alcohol for making the desired colloid.

5. *Mixing.* The compressed pyro cake is now placed in rotating drums and block breakers and broken up into a coarse, fluffy mass. It is then put into mixing machines where ether and diphenylamine are added. The charge is mixed for about 30 minutes,

during which it becomes partially dissolved or colloided by the ether and alcohol.

6. *Granulation.* After mixing, the charge is reformed into a block and taken to a press where it is first forced through the small holes of a strainer (macaroni) press to ensure a thoroughly mixed and uniform colloid and to eliminate lumps and foreign matter. It is again reblocked and taken to a graining press, where it is forced through the die and extruded in the form of a continuous cord of circular cross section with seven longitudinal perforations. The cord immediately passes to the grain cutter, which cuts it into grains of uniform length. In this form, it is known as "green" powder and is still fairly soft and pliable because of the excess of solvents which it contains.

7. *Drying.* After a special heat treatment for recovery of most of the solvents, the green powder is removed to large *dry houses*, where the solvent content is reduced to a predetermined amount. The drying process takes 4 to 6 months, depending on the percentage of residual volatiles desired and the size of the grain required. The percentage of residual volatiles remaining in each powder after drying varies from 3 to 7 percent, being greater in the larger granulations. After drying, the powder is blended with other poacher lots to make up one uniform lot of powder. Samples of this lot are proof-fired, and after acceptance the lot is assigned an index number. It is then ready for issue to the Fleet.

### 2C3. Characteristics of smokeless powder

Grains of smokeless powder have a hard, smooth finish and look very much like horn. When new, the grains are amber in color and are translucent. As the powder ages, its color becomes dark brown, then black, and finally opaque. These changes do not indicate any loss of stability.

Smokeless powder is subject to a very gradual chemical decomposition which may in time be a source of danger (spontaneous combustion) unless measures are taken to arrest such action. Like many explosive compounds, smokeless powder is in a state of unstable chemical equilibrium and is readily acted upon unfavorably by impurities which may be present with it. If decomposition takes place in any particle, the decomposition products will include nitrogen oxides which have an acid reaction and will facilitate further decomposition. The use of diphenylamine, whose action has already been explained, has greatly increased the stability life of smokeless powder. A powder which may have become *chemically* dangerous through partial decomposition is not dangerous for use in a gun, since a part of the decomposition which should take place in the gun, with sudden evolution

of heated gases, has already taken place and the powder has lost a corresponding number of heat units.

Excessive heat has a most unfavorable influence upon the stability of smokeless powder. At temperatures below 60° F., the stability is not appreciably affected, but at temperatures above 70° F., the rate of decomposition rises quickly, becoming high at 90° F., and dangerously accelerated at temperatures over 100° F. Precautions must therefore be taken to ensure the maintenance of a uniformly low temperature in the magazines in which powder is kept.

Since the presence of moisture favors decomposition of smokeless powder, the containers in which it is stored are made airtight, and every effort must be made to maintain their tightness. A leaky container may not only admit undesirable moist air to the powder, but may also permit the loss of volatiles through evaporation, especially if the air in the container is subjected to alternate expansion and contraction due to change in temperature. Such a loss of volatiles will increase the speed of burning of the powder to such an extent that excessive pressures will be produced in the gun. In this event the powder is *ballistically* dangerous.

#### 2C4. Triple-base powder manufacture

Triple-base powder, commonly called Cordite N or SPCG, is composed of four principal ingredients—nitrocellulose (19 percent), nitroglycerine (a little under 19 percent), nitroguanidine (55 percent), and ethyl centralite (a little over 7 percent). Of these 4, the first 3 are explosives. Ethyl centralite (also called carbamate) is the stabilizer. A small amount of potassium sulfate may be added as a flash inhibitor, and for some calibers other ingredients may be added in small amounts.

The manufacturing process is in general similar to that for pyro powder. It begins with passing the dehydrated nitrocellulose through a block-breaker screen (or this may be done before the nitrocellulose reaches the Cordite production plant). Then the other dry ingredients (except the ethyl centralite) are mixed with the nitrocellulose for 6 minutes. Next, a mixture of nitroglycerine and acetone (which desensitizes the normally very touchy nitroglycerine) is added to the dry mix, and mixing continues for another half hour. Then the ethyl centralite is added and mixing goes on for another 3 hours. More acetone and alcohol may be added if required during this step. This stage may end with maceration of the mix, if required.

The mix, which is by now mostly in colloid form, next goes to a "macaroni" press which squeezes it through strainers to remove uncolloided nitrocellulose and bits of foreign matter that may be present. The

"macaroni" is then pressed again into blocks, and is extruded through dies to give the final grain cross section. After this the extrusions are cut to proper grain length, and the powder goes to the final stages of its processing.

The "green" powder next goes through a combined screening-drying stage, in which clustered grains are separated, undersize grains and dust are screened out, and forced dry-air currents remove volatiles. After drying, the powder is blended with other lots and packed.

#### 2C5. Characteristics of triple-base powder

Triple-base (Cordite) powder grains resemble in size and shape conventional pyro powder grains for the same caliber, except that they have smooth, chalk-white surfaces. After considerable time in storage, the surface color may tend to yellow, but this is not a sign of deterioration.

Triple-base powders are far more stable in storage than equivalent pyro powder, partly because of their relatively low nitrocellulose content, partly because of their extremely small content of volatile components, and partly because of their low hygroscopicity. They are much more suitable as gun propellants than double-base powders like ballistite (described below) because nitroguanidine, in contrast to the mixture of nitroglycerine and nitrocellulose in double-base powders, is a "cool"-burning explosive. The gases produced by a triple-base powder with nitroguanidine have much less erosive effect than those of a double-base powder. Triple-base powders also have advantages in reduced production cost and reduced residue after burning, although they do in general require a larger variety of ingredients than pyro powder. They are also less sensitive to high temperatures in stowage.

#### 2C6. Shipboard tests and inspections of smokeless powder

The *Bureau of Ordnance Manual* gives the required periodic tests and inspections prescribed for smokeless powder aboard ship in order to ensure its safe storage.

For each index of powder aboard ship, a sample is provided in a glass bottle with a tight glass stopper, and is stored in the magazine containing that powder index. These *magazine samples* provide a means for daily visual examination of each powder index on board. A strip of methyl violet paper is kept in each sample bottle. Oxides of nitrogen, emanating as a gas from decomposing smokeless powder, will discolor the paper, changing it from violet to white. Such a change is a warning that the powder in the bottle and

the powder of which it is a sample have begun to decompose.

Additional signs of decomposition which may be noted by daily visual examination are:

1. Discoloration of grains, especially grains with orange or yellow spots, or grains differing markedly in color.

2. Grains showing fine cracks, especially if they lack their normal gloss.

3. Friable or easily crumbled grains. This applies especially to the discolored spots on grains and to the off-colored grains.

4. The unmistakable presence of nitrous fumes as determined by sight or smell immediately on opening the container. Only in the very worst cases are the reddish-brown colored fumes likely to be visible. Care should be taken not to mistake the normal ether-alcohol odor for the characteristic pungent odor of the oxides of nitrogen.

5. The metal of the container showing signs of a green or white corrosion on the inside.

6. The powder is in a soft or mushy condition.

Conditions 1, 2, and 5 indicate some decomposition has taken place, but the powder may still be usable. Surveillance tests should be made immediately to determine the extent of decomposition. Conditions 3 and 4 indicate advanced decomposition; the powder should be turned in to an ammunition depot for disposition. Powder in condition 6 is very dangerous and should be thrown overboard immediately.

The surveillance test consists in putting a sample of the powder in a tight, glass-stoppered bottle into an electrically heated surveillance oven, and exposing it to a constant temperature of 65.5° C (150° F.). The sample under test is examined once daily until red fumes appear, or 60 days elapse. If the red fumes appear within a minimum time as specified in OP 4 for that particular powder (for example, 16 days for 5"/38 powder), notify the Bureau of Ordnance and request disposition instructions.

If fumes appear after the minimum period specified by OP 4, but before 60 days, the powder is reasonably safe, but surveillance tests must be conducted at frequent intervals. If red fumes do not appear in 60 days, the powder is safe.

Surveillance testing equipment is carried at present on relatively few types of ships—BB's, CA's, CL's, CAG's, AD's, and several types of carriers. The equipment is optional on AE's. Other types of ships send samples to ammunition depots for test.

In general, Cordite type (triple-base) powders are not tested in surveillance equipment. At present, Cordite powders are subjected to methyl violet paper tests just as pyro powders are. However, because triple-base powders contain less than 20 percent nitro-

cellulose, and are much more stable than pyro, violet paper is not as reliable an indicator of triple-base propellant stability as it is for pyro powders. Improved indicators and test methods are now under development.

### 2C7. Black powder

Black powder (originally called gunpowder), the oldest of explosives, has undergone little change in its composition from earliest times to the present. It consists of a mechanical mixture of approximately 75 percent saltpeter (sodium nitrate), 15 percent charcoal and 10 percent sulphur, although these proportions may be varied somewhat, depending on the use for which the powder is intended. First used in guns in the early 12th century, black powder was the only propellant for firearms until the latter half of the 19th century, when nitrocellulose powders were developed.

Black powder is unsuitable as a propellant for several reasons:

1. It leaves a large amount of residue, thus fouling the gun bore.

2. It makes large quantities of black smoke when it burns.

3. Its high temperature of combustion causes rapid erosion of the gun bore.

4. Its velocity of reaction is too rapid, even with very large granulations.

Although black powder possesses practically unlimited chemical stability if stored in airtight containers, it deteriorates irregularly when exposed to moisture, which it absorbs readily. Black powder is not affected by moderately high temperatures, nor is it subject to spontaneous combustion at ordinary storage temperatures. It is, however, highly flammable and very sensitive to friction, shock, sparks, or flame. It is extremely quick and violent in its action when ignited. The larger the granulation of black powder, especially when pressed or cut into pellets, the slower the rate of burning. Black-powder dust is exceedingly dangerous, and its accumulation during the handling of any black powder should be prevented. *Black powder is the most dangerous of all explosives handled aboard a man-of-war.*

The uses of black powder are dependent on the size of its granulations. In the order of decreasing grain size, the types and uses of black powder in the United States Navy are as follows:

1. *Grained.*—Torpedo and depth-charge impulse charges.

2. *Granular.*—Ignition charges for propellants and for saluting charges.

3. *Fine-grain.*—Primer charges; expelling charge in illuminating projectiles.

4. *Meal.*—Pyrotechnics and fuzes.

### 2C8. Solid rocket propellants

Solid rocket propellants are double-base compositions with added ingredients for plasticizing, control of burning rate, and reduction of flash. Gas pressure during burning is about one-tenth of that in a gun barrel, and erosion effect is not important in this application.

A typical propellant grain is made up of a composition identified as Type N-2 (JPN), and its main ingredients are nitrocellulose (slightly over 51 percent) and nitroglycerine (a little less than 43 percent). It also contains two plasticizers to ensure homogeneity of composition (these are diethylphthalate, around 3 percent, and a trace of Candelilla wax), about 1 percent of stabilizer (ethyl centralite), a little over 1 percent of potassium sulfate to reduce flash, and a small amount of carbon black to control burning rate. There are a number of other compositions also used for rocket propellant grains, but they are classified, and this one will serve as a specimen for study.

As manufactured, the propellant is produced in the form of a sheet about 5 inches wide, 33 inches long, and 0.06 to 0.09 inch thick. To be converted into the grain which actually goes into the rocket motor, several sheets are rolled into "carpet rolls" and put into a press. Under high temperature and pressure

the propellant is extruded from the press through a die that gives it the cruciform (cross-shaped) or hollow cylindrical cross section required for the particular motor concerned. The charge is extruded as a homogeneous length of propellant, which is then cut and trimmed to grains of appropriate length. The grains are then turned in a special lathe to give them the proper dimensions for mounting in the motor. Single extruded rocket propellant grains range in size up to 60 inches in length and 6 inches in diameter.

From 1 to 4 grains of ballistite propellant are used as the propelling charge in a rocket motor. The grains are designed to burn at a uniform rate to provide a uniform thrust during burning. In cruciform grains provided with suitable plastic inhibitor strips the burning area, and hence the rate of gas production and the thrust, tend to remain constant throughout the burn time. In hollow cylindrical grains, plastic inhibitors bonded to the grain limit the burning area during the first part of the burn period. Cylindrical grains have holes at regular intervals to equalize the pressures inside and surrounding the cylinder.

Single grains for JATO units or for use as missile sustainer propellants are made as large as 25 inches in diameter and 10 feet long. Such grains are made by a casting process, and may contain ingredients other than the double-base mixture described above.

## D. Service High Explosives and Primary Explosives

### 2D1. General

The list of substances which can be grouped under the term *high explosives* is a long one which, however, may be materially reduced by eliminating explosives not suited for military purposes. The following conditions must be considered in choosing a military high explosive. Depending upon its use, it must:

1. Have proper insensitivity to withstand:
  - a. Shock of gunfire.
  - b. Shock of impact against armor, if used for projectile filler.
  - c. Shock of handling.
2. Have maximum power.
3. Have stability to withstand adverse storage conditions, heat, moisture, etc.
4. Be easy to handle, load, and manufacture.
5. Produce proper fragmentation.
6. Be cheap and available in quantity.

A number of high explosives are derived from coal-tar products. When coal is subjected to destructive distillation, coke, gas, and coal tar are obtained. Coal tar is a heavy liquid of a complex nature, which on further distillation will yield aromatic hydrocarbons

(benzene, toluene, xylene, naphthalene, and anthracene) and aromatic alcohols (phenol and cresol). From these substances, or from other substances obtained from them, explosives may be made by nitration.

High-explosive charges are usually loaded by melting and pouring, if the kind of explosive substance used permits this treatment. This gives greater density of the charge and hence greater explosive effect in a container of given volume.

### 2D2. TNT (trinitrotoluene)

TNT, the most familiar of all military high explosives, is obtained from the nitration of toluene in three successive steps. TNT is a white crystalline substance when pure, and varies in shade from a light yellow to a dirty brown when impurities are present. When pure, it melts at about 80.5° C. (177° F.). TNT is neutral in reaction and, even under unfavorable conditions of moisture and temperature, does not form sensitive compounds by combination with metals. It has high chemical stability even when subjected to temperatures as high as 150° F. for considerable periods of time, and can withstand great variations in temperature.

TNT is relatively insensitive to shock, friction, or pressure. When ignited, unconfined, it burns slowly with a dense black smoke and without explosion. However, in a hot fire it will explode with violence. TNT can be melted and cast into any form desired. This property makes it a very convenient substance for explosive charges. The rate of detonation of TNT is about 7,000 meters per second.

In a cast form, TNT is rather difficult to detonate and usually requires a booster such as refined granular TNT to provide the shock necessary to ensure complete high-order detonation. TNT is not, however, as insensitive as one may suppose. Small particles of TNT have been known to detonate when scraped with a knife.

The presence of moisture in TNT adds greatly to the difficulty of detonating it and probably decreases its explosive force. It is, therefore, of greatest importance that TNT boosters be kept dry.

A dark-brown oily liquid frequently separates out of cast TNT, and may exude from the containers after a period of storage. This *exudate* consists of isomers of TNT and lower nitrotoluenes. (Isomers are substances having the same chemical formula but with molecular arrangements and melting points different from those of the original substance.) Such exudates are relatively insensitive, but when mixed with an absorbent cellulose material, form a low explosive which is easily ignited, burns rapidly, and may even be detonated. An accumulation of exudate is considered both a fire hazard and an explosive hazard. Exudates discovered when cast TNT is inspected should be immediately removed. Large cast TNT charges must not be stowed on wooden or linoleum-covered decks, nor on any material that is likely to absorb the exudates. Exudate may be removed with carbon tetrachloride or alcohol, or, if discovered before it hardens, by water and a stiff brush. Because of its sensitivity, exudate must never be removed by steel scrapers, nor should soap or other alkaline solutions be used to remove it.

TNT has many uses. It may provide main disrupting charges in projectiles, torpedo war heads, depth charges, mines, bombs, grenades, boosters, demolition charges, etc. It is more frequently used as a component in other explosives. For fuzes and boosters, only a refined granular or crystalline TNT of high melting point is used. For large charges such as those in mines, bombs, etc., cast TNT of one of the lower grades and lower melting points is ordinarily used. TNT is not sufficiently insensitive to be a satisfactory filler for armor-piercing projectiles.

TNT may be mixed with other materials for certain applications. For example, TNT, with its relatively low melting point (80.5° Centigrade when pure) can

be *cast-loaded*—that is, it can be poured into the burster cavity of a projectile and permitted to harden. Many other high explosives have melting points too high for this technique. But by using TNT as a vehicle, it is possible to cast-load a mixture of TNT and some other explosive. Thus a mixture of TNT and RDX (to be discussed below) can be cast-loaded.

Two other fairly common mixtures including TNT are *amatol* and *tritonol*. *Amatol* is a mixture of TNT and ammonium nitrate, and is used in large aircraft bombs. The mixture is less expensive than straight TNT. *Tritonol* is a mixture of TNT and aluminum powder. In this and other mixtures containing aluminum powder, the aluminum has the effect of improving the brisance of the explosive components, although it does not significantly affect the power of the explosive.

### 2D3. Explosive D (ammonium picrate)

This explosive, patented in 1888, was for many years the secret high explosive of the United States. Its particular importance as a military explosive lies in its marked insensitivity to shock and friction. It is only slightly inferior to TNT in explosive strength. It is a crystalline powder of light-yellow color which is loaded in projectiles by pressure tamping. It is only slightly hygroscopic, but, when wet, forms sensitive and dangerous picrates with copper and lead. Although it does not form dangerous compounds with iron, it does cause corrosion; the interiors of projectiles are therefore painted or varnished before being filled. It has high chemical stability, even when subjected for considerable periods of time to temperatures as high as 150° F. It cannot be melted and cast like TNT.

Explosive D is made by saturating a hot solution of picric acid (trinitrophenol) with ammonia water (ammonium hydroxide) or ammonia gas. This results in neutralizing the acid, which is shown by the formation of crystals. This solution, when the reaction is complete, is dumped into crystallization tanks, where the ammonium picrate crystallizes out. The crystals are removed, drained, and screened. The powder is then ready for packing.

Explosive D is used primarily as a burster charge for large-caliber armor-piercing projectiles, and armor-piercing bombs, as it will withstand the shock of impact against any thickness of armor. The advantage of this is, of course, that the armor-piercing projectile will have partially or completely penetrated the plate before it is detonated by the fuze action.

Aboard ship, Explosive D is found only in loaded projectiles or bombs and requires no special care, except to see that the projectile rooms are kept thoroughly dry and at moderate temperatures. In case of fire in the vicinity of projectiles, care should be taken

that they do not become heated to a high temperature. No special tests or inspections of Explosive D are required afloat.

#### 2D4. Tetryl (trinitrophenylmethylnitramine)

This high explosive is another aromatic nitrocompound. It is a yellow crystalline substance usually produced by the nitration of dimethylaniline.

Tetryl is more powerful than TNT and more sensitive to shock. It is stable at all ordinary temperatures, melting at 130° C. (266° F.). Tetryl is an excellent explosive for booster charges, especially in mines and torpedo war heads, which do not have to undergo the heavy shock of firing. Sometimes a mixture of tetryl and a primary explosive is used as a detonator.

#### 2D5. RDX

This high explosive, known also as "Cyclonite" and "Hexogen", is a fairly recent development. It is a fairly sensitive explosive, and is more powerful than either TNT or Explosive D. It is produced by the nitration of hexamethylenetetramine, an organic compound derived from ammonia and formaldehyde. Purification is accomplished by crystallization from acetone. The crystals are then coated with beeswax or similar waxes to reduce the sensitivity of the material. In this form, RDX is insensitive enough to permit handling. Further additions of less sensitive materials are necessary before it can be used as a military explosive. The forms in which it appears in service are:

1. *Composition A.* A mixture of about 91 percent RDX and 9 percent beeswax or synthetic wax. Since this composition has about the same sensitivity as Explosive D but is more powerful, it is now being used as a projectile filler in place of Explosive D.

2. *Composition B.* A mixture of about 60 percent RDX, 40 percent TNT, and less than 1 percent wax. It is used as a projectile and bomb filler.

3. *Composition C.* A plastic mixture of about 90 percent RDX and 10 percent emulsifying oil—used to advantage as a demolition explosive because of its plastic form.

#### 2D6. HBX

There are in service use two varieties of HBX—HBX-1 and HBX-3. HBX-1 is a cast explosive, consisting of a mixture of RDX, TNT, aluminum powder,

and a desensitizer composed chiefly of wax. It is stable, relatively insensitive to impact, and more powerful than TNT. It is used in rocket heads as a burster charge.

HBX-3 differs from HBX-1 in having a much larger proportion of aluminum powder to increase its brisance. It is otherwise similar to HBX-1, but has much greater destructive effect underwater. It is therefore used in depth charges and other underwater explosive devices.

#### 2D7. Primary explosives

Primary explosives are used in the early part of the explosive train, where sensitivity is important. For many years fulminate of mercury was the most important explosive used for this purpose. Because of its relatively poor keeping qualities, particularly under higher temperatures and in the presence of even a small amount of moisture, it is gradually being eliminated. Ammunition now being procured does not contain mercury fulminate.

The important primary explosives used in U. S. naval ammunition today are lead azide, lead styphnate, DDNP, tetracene, and nitromannite. To ignite a propellant, the primary elements in an explosive train must produce a hot flame of sufficient temperature, size, and duration for reliable action. To detonate a high explosive, the primary elements in the train must produce a shock sufficient to detonate the succeeding elements. The primary explosives mentioned above are used in these applications.

Detonators and primers differ chiefly in the auxiliary ingredients used to produce the effects desired. Thus, oxidizing agents such as nitrates or chlorates are added to increase impulse (shock effect) and sensitivity; abrasives like ground or powdered glass increase sensitivity to firing pin action; fuels such as antimony trisulfide increase flame energy. Explosive binders like nitrocellulose or nitrostarch are used to provide structure for the primary mixture and to hold it in place, and graphite or other electrical conductors are used to increase conductivity for electrical initiation. These components are used in various combinations, depending on the characteristics desired in the initiator.

For details concerning specific primary explosives and the design of explosive trains, see the *Ordnance Explosive Designer's Handbook*, published by the Navy as NOLR/1111.

## Chapter 3

# AMMUNITION

## A. General

### 3A1. Definitions

*Ammunition* is the complete assemblage of the component parts, or *ammunition details*, which, together, make up a charge or round for any type of weapon.

Ammunition details include primers, boosters, detonators, powder, powder bags, cases, fuzes, projectiles, etc.

### 3A2. Classification of ammunition

Ammunition is classified by type stowage. The classification consists of the following types:

1. Gun ammunition.
2. Bomb-type ammunition.
3. Rocket-type ammunition.
4. Guided missiles.
5. Pyrotechnics.
6. Chemical ammunition.
7. Demolition material.
8. Miscellaneous.

### 3A3. Gun ammunition

Gun ammunition comprises 4 types: bag, semifixed, fixed, and small arms. The distinction between the first 3 depends on the manner in which the charges are assembled. In *bag* ammunition, the primer, propelling charge, and projectile are separate units. In *semifixed* ammunition, the primer and propelling charge are contained in one unit, while the projectile is separate. In *fixed* ammunition, all 3 components are assembled in 1 unit. *Small-arms* ammunition will not be discussed in this text.

### 3A4. Bomb-type ammunition

Bomb-type ammunition is characterized by thin-walled containers, loaded with relatively large bursting charges. This ammunition depends for its effect upon the destructive blast of the explosive, rather than any penetrating qualities of the container. Included in the group are torpedo war heads, mines, depth charges, and some aircraft bombs. Some bombs are discussed in this chapter; for further information on

bombs, see *Naval Airborne Ordnance*, NavPers 10826. Other bomb-type ammunition is taken up in chapters 12-14 of this text.

### 3A5. Rocket ammunition

A rocket consists essentially of a *head* and a *motor*. The head may be solid or may contain a bursting charge. The motor contains fuel, either in the form of a large grain of powder or a liquid. The burning of the fuel releases the energy necessary for propulsion. To stabilize its flight, the rocket either has fins on its after end, or is made to spin by exhausting the motor gases through canted nozzles. Rockets are described more fully in chapter 11.

### 3A6. Guided missiles

A guided missile is an unmanned vehicle moving above the earth's surface, whose trajectory or flight path is capable of being altered by mechanisms within the vehicle. Guided missiles include, besides such control mechanisms, explosive war heads and power plants, usually of the rocket or jet type. For additional data on this subject, see chapters 11 and 29.

### 3A7. Pyrotechnic ammunition

Pyrotechnic ammunition may be classified according to use into three types: (1) signaling, (2) illuminating, and (3) marking. Pyrotechnic materials are mixtures of oxidizing agents and combustibles (powders such as magnesium and chlorate mixtures) to which other compounds may be added for such particular purposes as to color the flame or smoke.

### 3A8. Chemical ammunition

Included under this classification are all projectiles, bombs, grenades, candles, or other containers of compounds the purpose of which is to produce, when liberated, gas, smoke, or fire. Also, free fluids or gases released from aircraft tanks, projectors, or sprayers are designated as chemical agents.

Chemical ammunition may be designated according to the type of container, as *projectile*, *bomb*, or *gre-*

nade. However, the more usual classification, and the one used for storage purposes, is according to the nature of the filling:

**Group A.** Persistent vesicants. Vesicants blister the skin. The usual ones are mustard gas and lewisite.

**Group A-1.** Nonpersistent lethal gases. These gases, such as phosgene, injure the body when applied externally, breathed, or taken internally. Protection is not required in the open for more than 10 minutes if the wind velocity exceeds 2 mph.

**Group B.** Lacrimators and smokes. A lacrimator such as CH (chloracetophenone) is used primarily to cause weeping and irritation of the throat and lungs. The smokes, such as FM (titanium tetrachloride) and FS (sulphur trioxide in chlorosulfonic acid) are used for screening but have an irritant and, in enclosed spaces, a toxic effect.

**Group C.** Spontaneously inflammable agents such as WP (white phosphorus).

**Group D.** Readily inflammable mixtures such as TH (thermite), which burn rapidly and with extreme heat.

Chemical warfare is a specialized field which calls for specially trained men. The storage of chemicals requires extraordinary safety precautions. Although poisonous gases were not used in World War II, the Navy was prepared for defense and for reprisal in case the enemy initiated such tactics. Chemical warfare creates many problems in ship protection and decontamination which are the responsibility of the Damage Control Officer and are outside the scope of this book.

### 3A9. Demolition material

Explosives intended for such uses as blasting, eliminating hazards to navigation and obstacles to amphibious landing, and destroying gear to prevent capture by the enemy, comprise demolition material.

The use of blasting charges is a specialized art, requiring intensive training. Demolition techniques are taught in special Navy schools and will not be discussed in detail in this text. For major blasting operations, various forms of dynamite are used; but dynamite normally is not carried aboard ship.

Half-pound *demolition charge blocks*, consisting of either pressed TNT or cast TNT and tetryl, are issued to ships for general use. Large demolition charges, also consisting of TNT, and assembled with half-pound booster charges, are also issued for major projects, such as scuttling vessels. Charges of both of these types are detonated by means of *blasting caps*, set off by electric current.

Aboard ship, in wartime, there are mechanical devices the nature of which, preferably even the very existence of which, must under no circumstances be-

come known to the enemy. Because highly classified instruments must be completely destroyed if capture or abandonment ship is imminent, tiny bombs, called destructors, are attached to them, to be actuated at a moment's notice. Usually, they contain lead azide or TNT-tetryl, with proper electric ignition elements.

### 3A10. Shaped charges

Relatively small quantities of explosive known as shaped charges can be made to pierce heavy steel plate by employing them as *shaped charges* which direct the explosive force into a small and concentrated jet. This jet supplies a directional damaging action.

In an ordinary bursting charge the expanding detonation wave proceeds outward from the point of detonation, producing stresses on all portions of the enclosing case. The casing bursts into fragments under the action of these enormous forces. In a shaped charge, however, a portion of the case (fig. 3A1) farthest from the detonator is in the form of a regular cavity (usually a cone, hemisphere, or V-shaped groove) so that the detonation wave fronts impinge progressively over that portion of the case will cause compression toward the center of the cavity. Under the influence of this high-velocity compression, the portion of the case forming the cavity and known as the *liner* gasifies under the extreme pressures and temperatures. Most of it squirts forward in a narrow jet away from the advancing detonation wave. The front of this jet is composed of a large number of gaseous metallic particles moving at speeds of 20,000 to 30,000 feet per second. This is followed by the *slug*, consisting of moving particles, the residue of the highly compressed liner (or slug), and fragments from the skirt of the liner. Penetration is achieved when the high-velocity jet particles impinge upon the target somewhat in the manner that a stream of machine gun bullets entering the same hole would penetrate an earth bunker. The slug plays no role in penetration. Although confinement increases the penetration of the jet in some cases, the increase is slight and most shaped charges have only light confinement. A well-designed shaped charge will penetrate armor up to three times the diameter of the cone.

One important factor in the effectiveness of a shaped charge is the distance of the charge from the target surface at the instant of detonation. This distance, called *stand-off distance*, is necessary to permit effective focusing of the gaseous jet.

In demolition charges the stand-off is obtained by legs which hold the shaped charge at the proper distance. When a shaped charge is employed in gun projectiles or rockets, the nose will begin to crush before the fuze can detonate the charge. The nose is

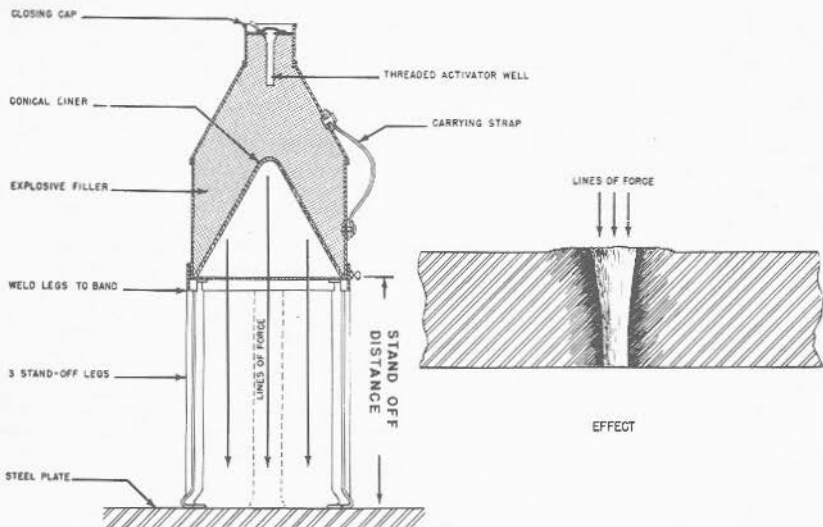

FIGURE 3A1.—Shaped charge and its effect.

therefore longer than the required stand-off distance by an amount calculated to allow for this crushing between time of impact and fuze functioning. In general the stand-off distance at the time of detonation should equal the diameter of the shaped-charge cone.

In addition to the penetrative properties of the shaped charge, the accompanying blast and fragmentation are important considerations. One new 5-inch rocket head is multipurpose in that it can be used for blast damage, fragmentation damage, or defeat of armor by shaped charge effect.

### 3A11. Miscellaneous types

Under this heading are grouped a variety of types for special purposes such as impulse ammunition, blank ammunition, trench warfare ammunition, and dummy ammunition.

An *impulse charge* is a propelling charge designed to project a missile a short distance. It usually con-

sists of black powder and is assembled in a cartridge case with primer. Torpedoes are propelled from above-water torpedo tubes by impulse charges. Impulse charges are also used for propelling depth charges.

*Trench-warfare ammunition*, still so designated in spite of the change in the concept of trench warfare, includes hand and rifle grenades and mortar ammunition. It is issued to Marines and special landing forces.

*Blank ammunition* contains no projectile but consists of a cartridge case with primer and powder charge. It is used to make a noise for saluting, or a smoke for signaling, and for training exercises.

*Dummy ammunition* includes any type of ammunition or any ammunition detail assembled without explosives. This type is used for training and test and is carefully marked so that it will not be confused with service ammunition.

## B. Propelling Charge

### 3B1. Gun ammunition

Propelling charges with their containers, primers, projectiles, and projectile fuzes are the major com-

ponents of a complete round of gun ammunition, whether bag, semifixed, or fixed. Each of these components will be examined in some detail in the remaining sections of this chapter. Each of the many naval

guns is provided with its own associated ammunition, designed in normal service use to impart to its projectile a specified velocity at the muzzle called *initial velocity* (abbreviated I. V.). Special powder charges may also be provided for use in experimental work, shore bombardment, or target practice when reduced velocity is desired. Unless such reduced charges are specifically designated, it will be assumed throughout this discussion that service I. V. are meant. Figure 3B1 shows typical rounds.

### 3B2. Bag ammunition

In bag ammunition the propelling charge is a separate unit. Large guns require large quantities of propellant powder to attain required projectile initial velocity. If the total amount of powder required for a 16-inch gun were placed in a single rigid container, the size and weight would make loading exceedingly difficult and slow. By packing the powder grains in fabric bags, it is possible to divide the charge into units each of which can be expeditiously handled by one man.

Bag charges are used in the United States Navy at the present time in some 8-inch guns and all guns larger than 8-inch. As recently as the beginning of World War II, bag-type 5- and 6-inch guns were still in use. The largest guns in present use, the 16"/50 caliber on the newest battleships, use six powder bags with each projectile.

### 3B3. Powder bags

The material used for powder bags is silk, because only this fabric will completely burn away when combustion of the charge takes place, leaving no smoldering residue to cause the premature explosion of the next charge loaded. Each bag is roughly cylindrical in shape. One end consists of an *ignition pad* containing black powder quilted into the fabric so as to keep the black powder evenly spread throughout the pad. Light-weight cloth, dyed red, is used for the ignition pad. A heavier weight of fabric is used for the rest of the bag. Bags are fitted with handling straps and lacing, which can be used to take up any slack in the bag.

Powder may be placed in the bags in either of two ways. It may be dumped in with no regard for the positioning of the individual grains; this produces an *unstacked charge*. Or the grains may be arranged in layers with the axis of each grain parallel to the axis of the bag; this is a *stacked charge*. The latter results in a smoother, more compact bag and provides for faster, more complete, and more symmetrical ignition.

The firing of the separate primer used with bag guns can be relied on to set off the black powder in the ignition pad, but may not be sufficiently potent to initiate combustion of the smokeless powder grains directly. It is essential, therefore, that each bag of a charge be loaded into the gun with the ignition pad aft, facing the breech plug and within a few inches of the next bag or of the breech plug and primer. This factor also dictates that the total length of the powder bags comprising a charge should be nearly equal to the length of the chamber of the gun. When, therefore, a reduced charge is made up, the *number and length* of the powder bags are unchanged, but the diameter of each bag is reduced.

The powder bags used in a 16"/50 caliber gun are shown in figure 3B2. The markings on such a bag should be noted. Those on the body of the bag indicate the designation of the gun, the index or identification number and the weight of the smokeless powder, the fraction of a full charge represented by the bag and whether that charge is service or reduced, the initial velocity for which the charge is designed, and the initials of the inspector. Markings on the ignition pad indicate the number of grams of black powder contained therein.

### 3B4. Powder tanks

Storage of smokeless powder must be both airtight and watertight if standard performance is to be maintained. The diphenylamine stabilizer contained in smokeless powder prolongs the life of the powder but does not prevent deterioration under adverse conditions. Since powder bags are neither airtight nor watertight, they are stored in tanks. These powder tanks are, therefore, important pieces of ordnance equipment which must be properly maintained. Leaky tanks admit moisture and air and allow ether and alcohol volatiles to escape.

Several types of tanks are used, but all fulfill the same basic powder-storage requirements. Top covers are variously constructed but all are designed to permit quick opening, because the number of loaded tanks allowed to be open at any one time is strictly limited by safety precautions. All powder tanks have handling aids, the large tanks having lugs to fit slings and the smaller ones having handles.

Tanks for powder bags contain wooden spacers to prevent building of a static charge which might ignite the powder by a spark.

(Bag movement within the tank during handling causes the static charge. The spacer separates the igniter pads from the end of the tank to prevent sparking which would ignite the black powder in the pads.)

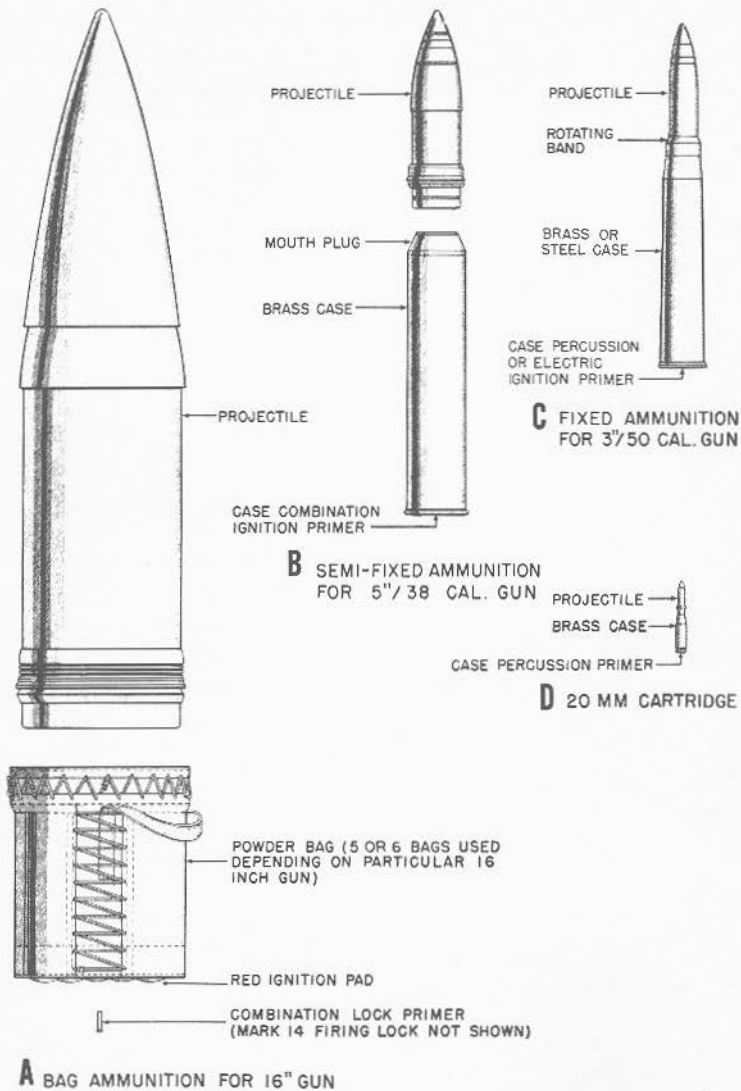

FIGURE 3B1.—Typical gun ammunition.

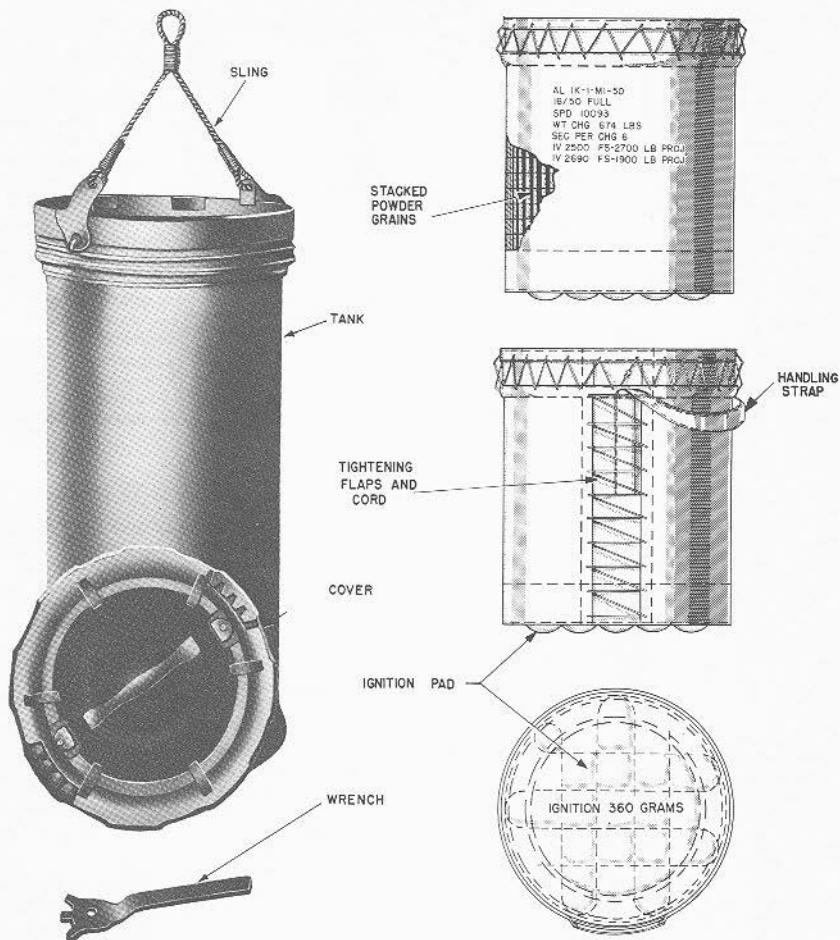

FIGURE 3B2.—Powder bags and storage tank for 16''/50 caliber gun.

**3B5. Case ammunition**

Gun ammunition which has its propellant charge in a metal *case* or *cartridge* instead of a bag is called *case ammunition*. (The term "cartridge" may also be applied to a complete round of small-arms ammunition.) Both semifixed and fixed ammunition are of this type. The factor that determines whether ammunition for a certain gun will be fixed or semifixed is the size and weight of a unit which can be handled by one man. Although mechanical improvements in loading tend to minimize this weight factor at the gun, it must still be considered in the supplying of reloads from handling

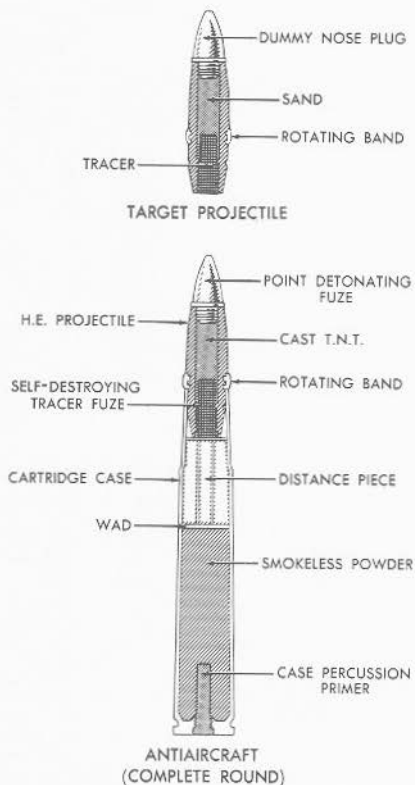
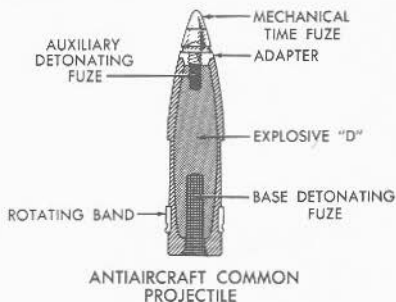
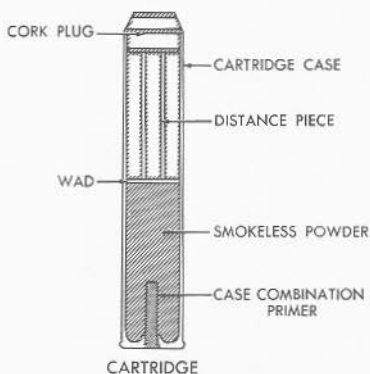

FIGURE 3B3.—40-mm ammunition (fixed).



ANTI-AIRCRAFT COMMON PROJECTILE



CARTRIDGE

FIGURE 3B4.—5"/38 ammunition (semifixed).

rooms below. The primer in case ammunition is inserted in the base of the case at the ammunition depot and is not removed or changed aboard ship.

The designs of various sizes of case ammunition are similar, as may be seen from study of figures 3B3 and 3B4. The preparation of the case assemblies is comparable up to the point at which the mouth of a case is sealed. In fixed ammunition the projectile is the seal; a mouth plug is used in semifixed charges. There are four steps in the assembly of case ammunition: (1) priming, (2) loading the propellant, (3) fitting a *wad* and sometimes a *distance piece*, and (4) inserting the *projectile* or mouth plug. In priming, the primer used is either screwed (40-mm, and larger) or force-fitted (smaller cartridge ammunition) into the base of the case. The desired weight of smokeless-powder grains is then dumped loosely into the case. In 40-mm and

larger guns, a cardboard disc, or wad, is forced into the case and a distance piece, if one is needed, placed on top. The mouth of a semifixed case is then sealed by the insertion of a mouth plug as illustrated by the 5"/38 case in figure 3B4. In fixed ammunition, the mouth of the case is sealed by forcing in the base of the projectile until the rear of the rotating band makes contact with the case.

A distance piece is made from a rectangular cardboard sheet, folded into a triangular shape and cut to the length necessary to fit the assembly, so that when placed between the wad and the case closure or mouth plug, it will hold the propellant firmly in place. A case mouth plug may be of cork, plastic, or cardboard and must be of sufficient strength to keep the contents of the case from spilling out under any conditions of handling or loading. In small-caliber ammunition, the fitting of wads and distance pieces may not be necessary if the propellant fills the case. The cartridge case itself is a hollow cylinder with either a straight or a bottle neck. The base has a rim around its circumference to facilitate extraction of the empty case from the gun. The empty cases can be reused

several times after being reprocessed at an ammunition factory.

### 3B6. Case ammunition containers

Since leaks may exist around the primer and the projectile or mouth plug, the case cannot always be relied upon to remain airtight. Therefore like powder bags, case ammunition is transported and stowed in containers which provide air- and water-tightness. There are several types of tanks and boxes in service, and no attempts will be made here to describe them in detail. It is sufficient to state that regardless of varying design, the container must, above all, provide proper storage for smokeless powder. In addition, the container should be strong but not unduly heavy, should handle easily, and should open quickly. Metal tanks made of aluminum most nearly conform to these requirements, and tanks in current use are of either aluminum or steel construction. Metal tanks are also advantageous in that they provide good storage in ready service racks on deck, or in ammunition-handling rooms not equipped to provide the best storage conditions.

## C. Primers

### 3C1. General

A primer is a device used to initiate a flame for the ultimate purpose of igniting a charge of propellant. In bag ammunition this flame is applied to the ignition pad (the auxiliary ignition charge) in the base of the powder bag, which in turn ignites the smokeless powder. In case ammunition the ignition charge is incorporated into the primer tube. Since the ignition charge incorporated in the bag can be proportional in size to the charge, the primers are the same for bag guns of all sizes. However, primers of different sizes must be used in cases of different sizes so that the amount of black powder in the primer may be proportional to the amount of propellant.

### 3C2. Types and classes of primers

Primers are divided into two types, depending on how they are used in the gun: (1) case, (2) lock. They are also divided into three classes, depending upon the method of firing: (1) percussion, (2) electric, (3) combination. *Percussion* primers are fired by the mechanical impact of a firing pin. *Electric* primers are fired by passing a current through a resistance filament surrounded by an initiating mixture. *Combination* primers may be fired by either of these methods.

The current trend is toward the use of electric primers only, in case guns of 3-inch and larger caliber.

Except for 5-inch mounts and older 6-inch turrets, case combination primers are used only in short cartridge cases for clearing the barrel after a failure to fire electrically.

The following service primers are in current use:

1. Case percussion primer.
2. Case electric primer.
3. Case combination primer.
4. Lock combination primer.

### 3C3. Case percussion primer

This type is used in light and heavy machine guns such as the 20- and 40-mm. In ammunition for the smaller guns, which has a relatively small amount of propellant, the primer consists only of a cap, an anvil, and a percussion-sensitive mixture. The composition of the mixture varies with the amount of heat, flame, and sensitivity desired. In operation, the firing pin strikes the inverted cup which holds the primer cap. This indents the cup, forcing the cap against the anvil and exploding the pellet of initiating mixture. The

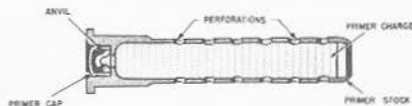

FIGURE 3C1.—Case percussion primer.

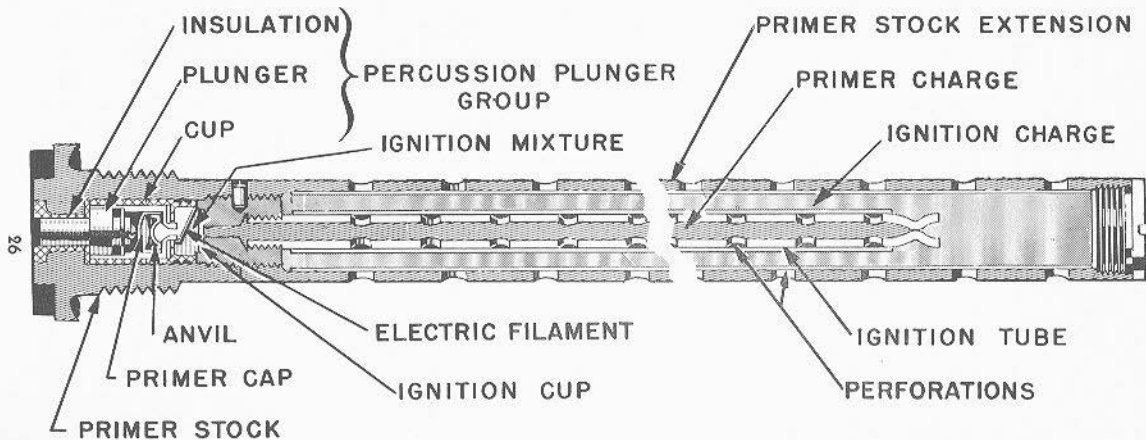

FIGURE 3C3.—Case combination primer.

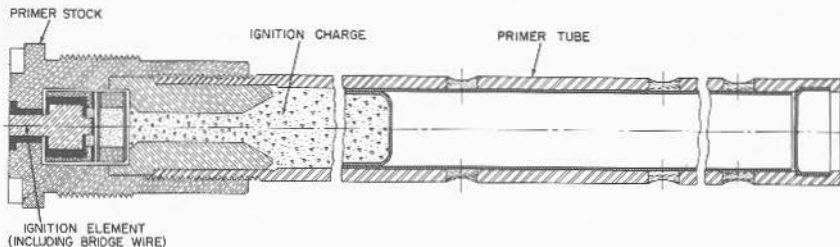

FIGURE 3C2.—Case electric primer.

resulting flame ignites the propellant. Where greater energy is required to ignite the propellant, the primer includes a black-powder charge which is ignited by the percussion cap. The 40-mm gun uses a primer of this type. See figure 3C1.

### 3C4. Case electric primer

Case electric primers (fig. 3C2) are used for the newer 3-, 5-, 6-, and 8-inch guns. These primers contain an electric ignition element which consists of two resistance filaments connected in parallel and surrounded by an explosive mixture, and a small black-powder primer charge. An electric current heats the filaments, which then ignite the explosive mixture. Flame from the initiating mixture ignites the black-powder primer charge, which in turn ignites the main black-powder charge of the primer.

### 3C5. Case combination primer

This type of primer is used in the 5"/38 caliber and the older 5"/54 and 6"/47 caliber guns. It is also used in clearing charges for all case guns of 3-inch caliber and larger. These primers can be fired, as indicated by their name, either by percussion or electrically. Electrical firing is considered the primary method; the percussion feature is a standby for use

in the event that electric firing fails. The percussion element is similar to that of the case percussion primer, except that the firing pin strikes a plunger which in turn explodes the cap against the anvil. The flames produced by the primer cap act directly upon the powder in the electric ignition cup. See figure 3C3.

The electric element consists of a high-resistance wire wrapped in a wisp of guncotton and contained in a mixture of pulverized guncotton and fine black powder in the ignition cup. This wire is connected at one end to the percussion plunger group, which is insulated from the primer stock. The other end of the wire is grounded through the primer stock and the cartridge case to the metal of the gun. In firing the gun an electric current is passed through the firing pin to the plunger; this heats the bridge wire, igniting the wisp of guncotton. The mixture in the ignition cup is ignited and in turn fires the black-powder primer charge. The primer charge is surrounded by the larger black-powder ignition charge and placed in an outer perforated tube, which amplifies the heat and flame sufficiently to surround the propellant charge.

### 3C6. Lock combination primer

The same type and size of primer (fig. 3C4) is used in all United States Navy bag guns. A primer is

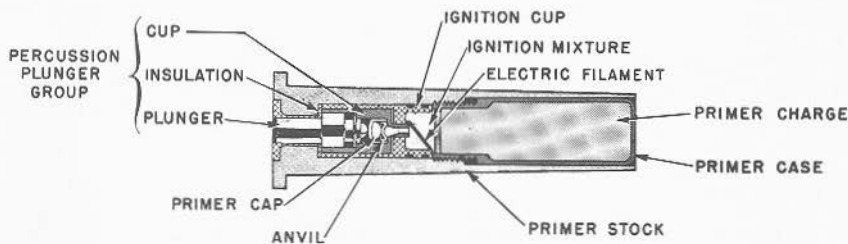

FIGURE 3C4.—Lock combination primer.

placed by hand in the firing lock of the gun each time the gun is loaded. There is no ignition charge in the primer, as one is included in the assembled powder

bag. The percussion and electric features of the lock combination primer are the same as those of the case combination primer.

## D. Projectiles

### 3D1. General

The projectile is that part of a round of gun ammunition which is expelled from the gun by the force of the explosion of the propelling charge. Present-day projectiles are elongated cylinders with a pointed front end. The application of the principle of rifling to guns caused the abandonment of the earlier spherical projectile. Rotation of the projectile permitted the use of a longer and heavier projectile, thus obtaining vastly increased range, accuracy, penetrative ability, and sectional density. (See art. 3D5.)

Modern small-arms projectiles often consist of solid metal; projectiles used in larger guns, however, are assemblies of several components. The three essential parts are the metallic *body*, the explosive *bursting charge*, and the *fuze* which sets off that charge. There may also be a *tracer* to make the projectile more readily visible during flight. Fuzes and tracers will be discussed in the next section of this chapter.

### 3D2. Projectile bodies

The solid bullet damages by impact alone. Assembled projectiles, however, inflict damage primarily by the blast of the high-explosive charge and the resulting high-velocity fragments.

The external shape of the projectile is designed to obtain the desired flight characteristics of stability and minimum air resistance. The form of forward end which best fulfills these conditions is the *ogive*. An ogive (fig. 3D1) is the shape generated by the revolution of an arc of a circle about a chord. In a projectile the chord is the axis of the projectile and the radius used is about nine times the diameter (caliber) of the projectile. (In small-caliber projectiles a cone is sometimes used instead of an ogive.) Aft of the ogive a projectile is cylindrical. The cylindrical shape may continue to the base, in which case the projectile is said to have a *square* base; or the after portion may be slightly tapered or conical, in which case the projectiles are described as *boat-tailed*. The corner of the base in either type is usually turned to a small radius. In fixed ammunition the form of the after end is influenced by the need for providing a bearing surface for the lip of the cartridge case.

Between the two ends lies the cylindrical body of the projectile. Near the after end of the cylindrical part of the projectile is the *rotating band*; at the forward end is the *bourellet*. These two surfaces, slightly

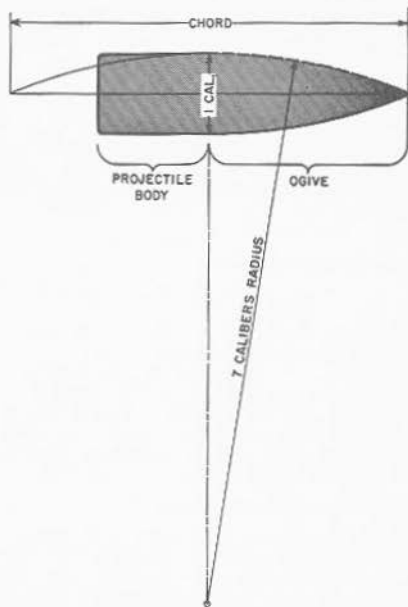

FIGURE 3D1.—Ogive characteristics.

raised above the body, provide the support and bearing which steady the projectile in its passage through the gun. They must be some distance apart to prevent excessive wobbling in the bore. Except for the bourellet, the projectile does not require a fine machined finish; experimental firings have indicated that fine body finish adds very little to projectile accuracy. See figure 3D2.

### 3D3. The bourellet

The forward bearing surface of a projectile is machined to a fine finish to reduce friction and minimize the wear of the gun. In small projectiles the entire body forward of the rotating band may be finished to

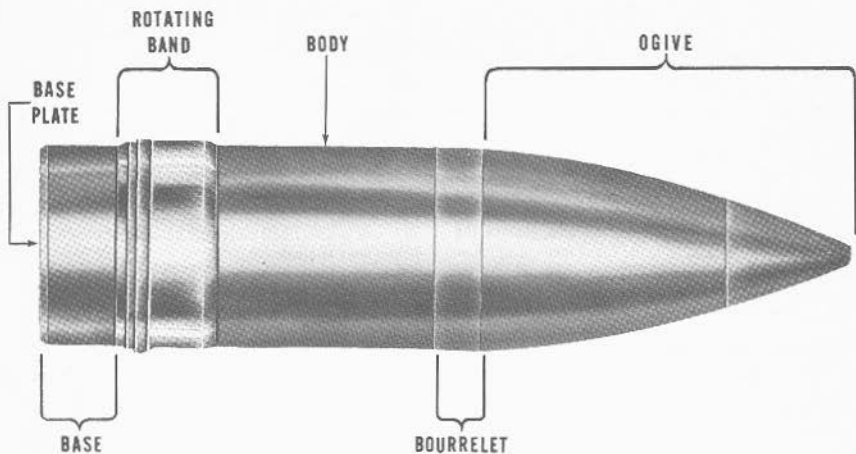

FIGURE 3D2.—Main parts of projectile.

bourrelet diameter. On large-caliber projectiles additional bourrelets, abaft and forward of the rotating band, are added to provide better support, especially during ejection from the muzzle. A certain clearance must be provided between the bourrelet and the lands (the raised portions of the rifling). Standard United States Navy practice requires a specified bourrelet diameter 0.015 to 0.023 inch (in different-caliber projectiles) smaller than the diameter of the bore. To this margin is added a manufacturing tolerance of minus 0.005 to 0.007 inch, so that total clearance limits vary from 0.015 to 0.030 inch. Unnecessary clearance adversely affects accuracy and fuze performance and may mar the rifling by excessive wobble.

#### 3D4. Rotating band

The three primary functions of the rotating band are to seal the bore, to position and center the rear end of the projectile, and to impart rotation to the projectile. Its secondary function is to hold the projectile in its proper position in the gun after loading and ramming, and to ensure that it will not slip back when the gun is elevated. The band has considerable effect on muzzle velocity, range, accuracy, and the life of the gun.

Rotating bands are usually made of fine copper; in major-caliber projectiles a small percentage of nickel is added to provide greater strength. Some projectiles

of recent design have been banded with gilding metal (90 percent copper, 10 percent zinc), which increases strength and reduces the amount of copper deposited in the bore of the gun.

To reduce dependency on copper for this use (copper is increasing in military importance while it becomes scarcer and more expensive) rotating bands of sintered iron are under development.

United States Navy projectiles generally have rotating bands about one-third caliber in width. Foreign services sometimes use narrow multiple bands on major-caliber projectiles. The rough band is assembled (after heating it, in 8-inch and larger calibers) by slipping it over the rear of the projectile and pressing it into a score cut into the body of the projectile. This scoring usually includes a dovetail on each edge to assure that the band will not be thrown off by centrifugal force. Either waved ridges, longitudinal nicks, or knurling are provided on the bottom of the score to ensure against band slippage during rotary acceleration.

The forward edge of the band is slightly conical, to facilitate engagement with the origin of rifling. The cone, during loading, wedges into a seat at the origin of the rifling (except in fixed ammunition) and holds the projectile in place during loading and elevating. The central portion of the band is cylindrical and of a slightly greater diameter than that of the bore plus

the depth of the rifling. This portion is sometimes divided by circumferential grooves, called *cannelures*, which provide space into which displaced copper may be wiped. In the after part of the band separate-loading projectiles have a raised lip followed by an especially deep cannellure. The lip serves to ensure a good gas check and also to prevent overramming in a badly worn or eroded gun.

The purpose of the cannellures is to minimize the formation of a fringe or skirt from the excess metal which is wiped rearward. Such a fringe is likely to flare outward, at the muzzle of the gun, due to the effects of the gases and of centrifugal force, and cause loss of range and accuracy. Bands on which the lip is well forward of the end of the band and is undercut with a deep cannellure are known as *nonfringing*.

### 3D5. Weight of projectiles

Within reasonable limits, a gun can fire projectiles of varying weights. Approximate weights of United States Navy projectiles are determined by the formula

$$W = \frac{d^3}{2}$$

in which:

$W$  = weight of projectile in pounds, and  
 $d$  = caliber of gun in inches.

The weight of the projectile per square inch of bore is called *sectional density*. It is represented by the expression

$$SD = \frac{W}{A}$$

in which:

$SD$  = sectional density.

$W$  = weight of projectile in pounds.

$A$  = area of bore, including grooves, in square inches.

This ratio varies with the size of the gun, averaging approximately six-tenths of the caliber. The concept of sectional density helps the designer to avoid designing a projectile of given diameter and weight either too long or too short for proper stability.

The distribution of weight in a projectile is a matter of considerable importance. The center of gravity should be in the longitudinal axis and close to or abaft the center of form.

### 3D6. Classification of projectiles

All gun projectiles, other than small arms, share the characteristics thus far described, but since targets differ in character, projectiles must differ in design, the better to defeat them.

The primary classification is into three general types:

1. Penetrating.
2. Fragmenting.
3. Special-purpose.

### 3D7. Penetrating projectiles

This type includes *armor-piercing* (AP) and *common* (Com). They are designed to penetrate, respectively, heavy and light armor. The usual bursting charge for these types is Explosive D, which is insensitive enough to permit penetration without premature detonation. The characteristics which make that possible will be described under the heading of penetration in the next chapter.

### 3D8. Fragmenting projectiles

These projectiles are designed to inflict damage both by blast effect and by *fragmentation*; that is, breaking up into small high-velocity fragments. They are characterized by thin walls and large cavities for the explosive filled. The general type is subdivided as follows:

1. *High-capacity* (HC) projectiles (fig. 3D3) are used against unarmored surface targets, shore objectives, or personnel. Since no penetration ability is required, explosives more sensitive than Explosive D may be used.

2. *Antiaircraft* (AA) projectiles are designed for use against airplanes in flight. Except for fuzing they are substantially the same as high-capacity in the

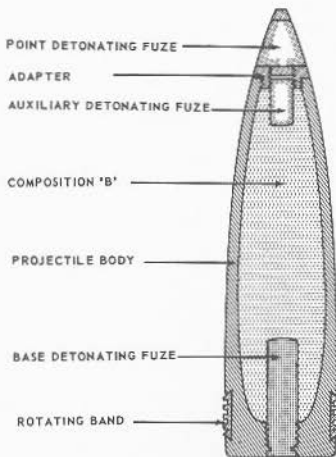

FIGURE 3D3.—6"/47-caliber high-capacity projectile.

larger calibers. In smaller sizes the explosive often contains an incendiary element.

3. *Antiaircraft common* (AAC) projectiles are a dual-purpose design, combining the qualities of anti-aircraft projectiles with the toughness necessary to penetrate steel plating not of armor thickness. The type of fuzing will depend on the use. The walls may be heavier than those of the other thin-walled types, and the filler is usually Explosive D.

### 3D9. Special-purpose projectiles

These are not intended to inflict damage by explosion or by fragmentation. Their construction incorporates no strength other than that required to withstand discharge from the gun without damage to the contents. If the filler includes any explosive, it is a small charge designed to expel the contents of the projectile. See figure 3D4. Some of the common varieties are:

1. *Illuminating* (Illum) projectiles, often called star shells (SS), contain a bright flare attached to a parachute. They are expelled from the projectile body by a small black-powder charge which also lights the flare. As the parachute slowly lowers the flare, it serves to illuminate the target.

2. *Smoke*, or white phosphorus (WP), projectiles contain tubes of that substance which are scattered and burst by a small black-powder charge. White phosphorus produces a screening smoke. It also has some incendiary effect.

3. *Window* (W) projectiles contain metal foil strips, which, when scattered high in the air by the small burster charge, serve to confuse enemy radar operators.

4. *Nonfragmenting* projectiles are used for anti-aircraft gun practices. They contain a smoke-producing substance, available in various colors, which makes it possible to observe the bursts without close bursts destroying the target.

5. *Target or blind-loaded* (BL) projectiles contain an inert substance, often sand, designed to give the same weight and balance characteristics as explosive fillers. In large calibers (6-inch and above) target projectiles simulate the AP design but have no filler other than the spotting color.

6. *Proof-shot* projectiles are used for proof tests of guns at the proving ground.

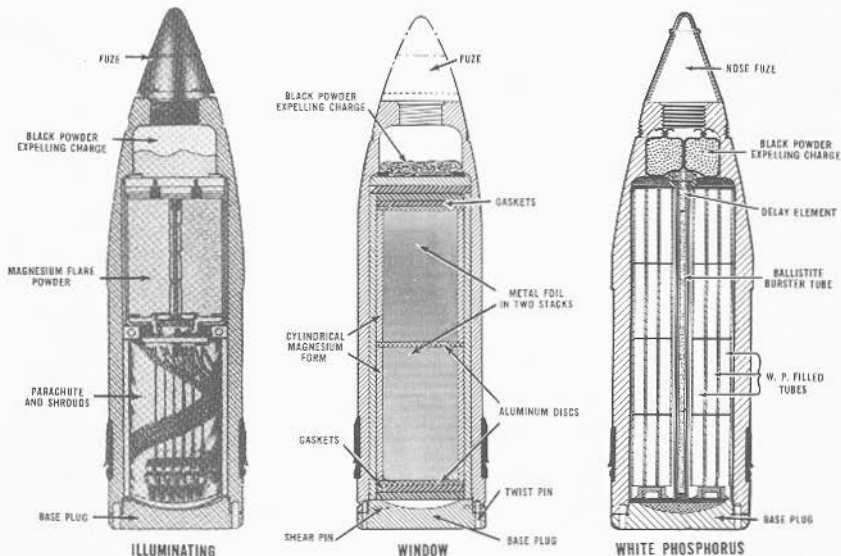

FIGURE 3D4.—Special-purpose projectiles.

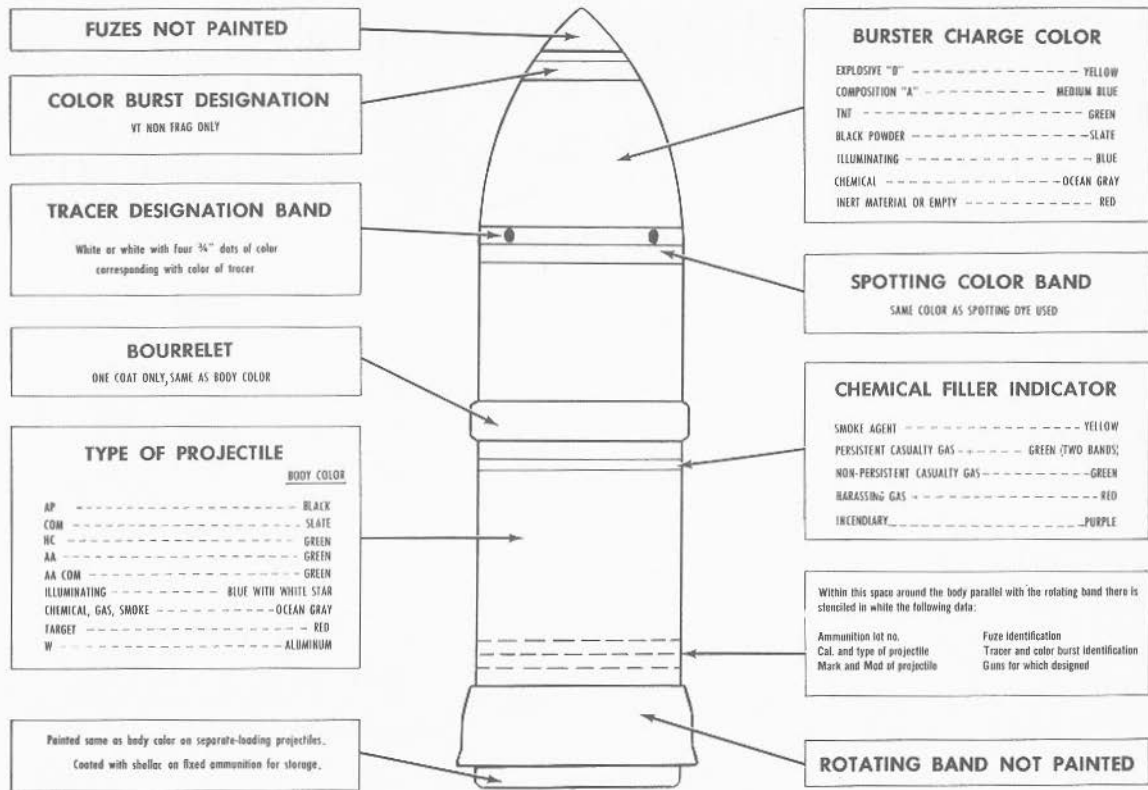

FIGURE 3D5.—Projectile markings.

**3D10. Dye loads**

Penetrating projectiles designed primarily for use against surface targets usually contain small quantities of dye, so placed in the nose of the projectile as to be dispersed upon water impact. This dye colors the splash produced by the hit and thus allows a ship to identify its own splashes. Standard practice is to issue to each ship in a division its own identifying color. Available colors are red, blue, green, and orange.

**3D11. Projectile markings**

Projectiles are painted various colors to facilitate rapid identification by gun crews. Nose fuzes and rotating bands are never covered with paint. Bourrelets are covered with one thin coat of paint only, and may never be repainted or retouched. The remainder of the projectile is painted according to the code set forth in figure 3D5, which applies to all calibers larger than 40-mm. Separate special codes are used for painting 20- and 40-mm projectiles.

**E. Fuzes and Tracers****3E1. General**

A projectile fuze is a mechanical, electrical, electronic, magnetic (or combination) device which will detonate or ignite a charge in a projectile at the time and under the circumstances desired.

Fuzes may be classified according to function (impact, time, or proximity), the position of the fuze in the projectile (nose or base), type of mechanism or principle utilized (mechanical or VT), and specific action at time of functioning or initiation (ignition or detonation). Figure 3E1 illustrates typical fuzes.

Typical examples of nomenclature for Navy fuzes are as follows:

1. Auxiliary detonating (ADF).
2. Base detonating (BDF).
3. Mechanical time (MTF) or electrical time (ETF).
4. Point detonating (PDF).
5. VT or proximity (VTF).

Point detonating, time, and VT fuzes may all be called *nose* fuzes because of their location in the projectile. Fuzes are designated as *detonating* when they contain within themselves a high-explosive charge sufficient to set off a high-order explosion in the burster. *Ignition* fuzes contain black powder sufficient to ignite the burster of small projectiles. In larger projectiles such fuzes function indirectly through an auxiliary detonating fuze.

**3E2. Fuze safety**

It is necessary for the safety of personnel that a fuze be made inoperative until the projectile is well clear of the muzzle and of the firing ship. A fuze is said to be *armed* when its component parts are so arranged that it can operate to set off the next explosive in the chain. It is *unarmed* when its safety features are so functioning as to prevent its operation.

A satisfactory fuze must meet these requirements:

1. It must be safe to handle; that is, the fuze must not become armed if dropped or joggled.
2. It must be safe within the bore of the gun and

for a sufficient distance outside to ensure security of personnel in the vicinity.

3. It must initiate the explosion of the filler at the proper moment, whether on impact or at a specified time.

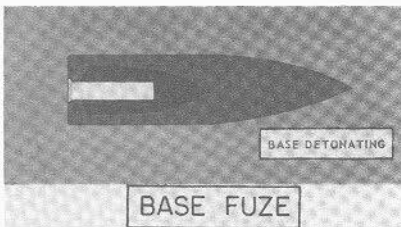
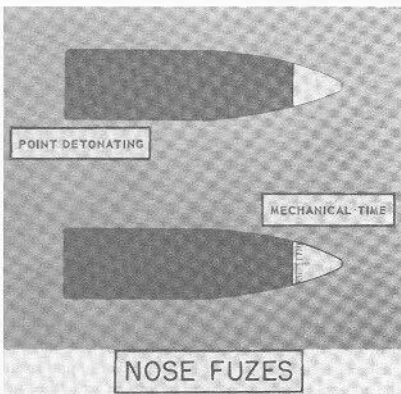

FIGURE 3E1.—Location of fuzes in projectiles.

### 3E3. Fuze operation terminology

If fuzes were not equipped with safety features, they would be relatively simple. The need for safety makes up for complicated operation, which depends for its initiation on certain forces brought into play when a projectile is fired from a gun. Forces which may be used to operate fuzes are:

1. *Setback.* The force of inertia which tends to move all fuze parts to the rear as the projectile is initially accelerated in the bore of the gun.

2. *Angular setback.* The force of inertia, which tends to resist the initial rotational acceleration of the projectile in the gun.

3. *Centrifugal force.* The continuous force, caused by the rotation of the projectile in flight, which tends to move all fuze parts radially away from the axis of the projectile.

4. *Creep.* The continuing inertial force resulting from the deceleration of the projectile in flight, caused by air resistance, which tends to move forward the fuze parts not exposed to the air.

5. *Impact.* The sudden inertia force which tends to move all fuze parts forward when a projectile strikes.

6. *Target contact.* The rearward movement of a firing plunger or other device when the projectile contacts the target material.

The magnitude of some of the forces is illustrated in the table below.

### 3E4. Auxiliary detonating fuzes

"Aux det's" are used in conjunction with all types of nose fuzes in HC, AA, and AAC projectiles of 3-inch and greater caliber. They are interposed between the nose fuze and the bursting charge of the projectile to provide a heavier shock for detonating the bursting charge. They also act as a safety feature, preventing the projectile filler from exploding in case the nose fuze should be accidentally actuated prior to the arming of the auxiliary detonating fuze.

### 3E5. Base detonating fuzes

Base fuzes are used alone in armor-piercing and common projectiles. They are used in combination with nose fuzes in such dual-purpose projectiles as AAC and IIC. In the latter case their functioning is completely independent of the nose and auxiliary fuzes, the former of which may for certain purposes be replaced by a *steel nose plug*.

All base detonating fuzes function on impact; some, however, incorporate a delay feature. Base detonating delay fuzes function a short time (0.02 to 0.033 second) after the projectile hits the target, thus allowing time for armor penetration. Base detonating non-delay fuzes contain no actual delay element, but a slight inherent mechanical delay provides a time margin sufficient for the penetration of thin sheet metal.

### 3E6. Time fuzes

In most calibers of gun projectiles, time fuzes are clockwork mechanisms used to obtain timed air bursts. They are used in AA, AAC, AA (non-frag), IIC, Illum, WP, and W projectiles of 3- to 6-inch sizes and in IIC projectiles of 8- to 16-inch caliber. There are two general types of mechanical time fuzes: one type depends for its action solely upon centrifugal force; the other is a spring-driven variety. The centrifugal type is less affected by long periods of storage, but the spring-driven fuzes are more satisfactory for use on large projectiles which have slower speeds of rotation. Each type is made in several marks and mods for various calibers.

A highly accurate electric time fuze that can be set very quickly (and thus reduces "dead time" to the vanishing point) is under development at this writing.

### 3E7. Point detonating fuzes

Point detonating fuzes are designed to function on impact with the target. They have the advantage of being faster acting on impact than base detonating fuzes. One group of such fuzes is used in place of

FORCES AFFECTING FUZE OPERATION

Projectile	Muzzle velocity fs	Max. bore pressure in new guns	Maximum setback force*	Spin at muzzle rps	Maximum retardation** (creep force)*
20-mm	2,725	24 long tons/in <sup>2</sup>	96,566g	1,154	
5"/38 AAC	2,600	18 long tons/in <sup>2</sup>	14,344g	208	7.2g
16"/50 AP	2,500	18 long tons/in <sup>2</sup>	3,003g	75	1.1g

\*g Equals the pull or force of gravity.

\*\*Maximum occurs a short distance from the muzzle.

mechanical time fuzes in connection with shore bombardment with HC, AAC, and WP projectiles. Other marks of point detonating fuzes are used in 20- and 40-mm projectiles, for which no other type fuzes are provided (20- and 40-mm AP projectiles are solid metal, except for the tracer cavity, and thus unfuzed).

Figure 3E2 shows a sectional view of the 40-mm Point Detonating Fuze Mark 27. This is a simple fuze, an explanation of which will illustrate typical fuze operation and safety features. The fuze is composed of four major parts: the fuze body, the magazine, the firing-pin holder, and the rotor block assemblies. The forward section of the fuze body contains the plastic firing-pin extension or hammer, the stab-type firing pin, detents and springs contained in the firing-pin holder assembly, and the rotor block with rotor, detents, springs, and rotor cover. The magazine is screwed into the after end of the body. The fuze is designed:

1. To detonate the projectile explosive charge and thereby burst the projectile with high-order detonation instantaneously upon impact.

2. To ensure safety and prevent detonation of the projectile when fired in a gun or in normal flight until detonated by impact.

**Operation.** On examining figure 3E2 the student will see that the firing pin cannot move aft (to the left in the diagram) because the firing-pin detents prevent it from doing so. Also, the detonator is not in line with the firing pin, so that, if the firing pin should somehow move aft, it would strike the rotor body and not the detonator. If the detonator should explode, it would not detonate the booster. The rotor, and consequently the detonator, is held in the unarmed position by the rotor detents, which fit into the rotor body as shown in the diagram. The rotor body also contains two lead counterweights.

When the projectile is fired, the rifling in the gun rotates the projectile. As the projectile spins, centrifugal force causes the firing-pin detents to move outward, freeing the firing pin. The rotor detents also move outward, freeing the rotor. Centrifugal force also acts upon the lead counterweights in the rotor body, tending to move them outward. This causes the rotor body to rotate, bringing the detonator into line with the firing pin and lead-in. The fuze is now armed.

Upon impact, the firing pin is rammed aft, striking and exploding the detonator. The detonator explodes the booster, which in turn detonates the burster charge of the projectile.

### 3E8. VT fuzes

The radio proximity or VT fuze is used in all of the types of projectiles which can use mechanical time

fuzes except illuminating and window (which are not supposed to be exploded in the immediate vicinity of a target). The VT fuze is a self-contained, radio-controlled fuze capable of transmitting pulses of radio energy, and of receiving a portion of these pulses which may be reflected by a target. The fuze fires when the returning signal is of sufficient strength, due to proximity to the target, to trigger the firing circuit. Essentially, the fuze is an extremely rugged radio transmitting and receiving station, which fits into the nose of a projectile and is so compact that it displaces a volume less than half of an ordinary pint milk bottle. See figure 3E3.

The principle of its operation can best be illustrated by describing the firing of a typical VT-fuzed projectile. Not only are VT fuzes as rugged as most fuzes, but they have been provided with reliable safety features. As a result, in safety of handling, safety in the bore of the gun, and freedom from muzzle bursts, they are as safe as any fuzes used by the Navy.

At the instant the projectile is fired, a tiny wet battery that furnishes energy to the fuze begins to be activated. The shock of fire breaks a small glass vial filled with liquid electrolyte. Centrifugal force in the rotating projectile causes this liquid electrolyte to flow toward the outside of a cylindrical cell through a stack of thin ring-shaped plates that have been carefully insulated from each other. Contact between the electrolyte and the plates makes the battery electrically active. Within a half second after the battery has become active, it has charged a firing condenser with electricity. Once this condenser is charged and a mercury safety switch has been opened, the projectile is "armed", and ready to detonate when a target influences it to do so. All this has been accomplished by the time the projectile has traveled four or five hundred yards.

As the projectile speeds through the air at a rate of approximately 2,600 feet per second, a radio oscillator sends out electromagnetic waves or impulses at the speed of light. These impulses will be reflected back to the oscillator by any target that gives a radio reflection, such as metal objects, water, or earth.

At first the projectile is so far from the target that these impulses are not returned in any strength. But as the projectile approaches closer to the target the oscillator receives ever stronger reflected impulses. These incoming impulses interact with outgoing impulses to create a "ripple pulse" which is amplified by vacuum tubes. If the projectile comes within a radius of about 75 to 100 feet of its target, this "ripple pulse" becomes powerful enough to trigger a thyratron tube which acts as an electronic switch. This releases the electrical energy stored in the charged condenser which, in turn operates an electrical primer. The

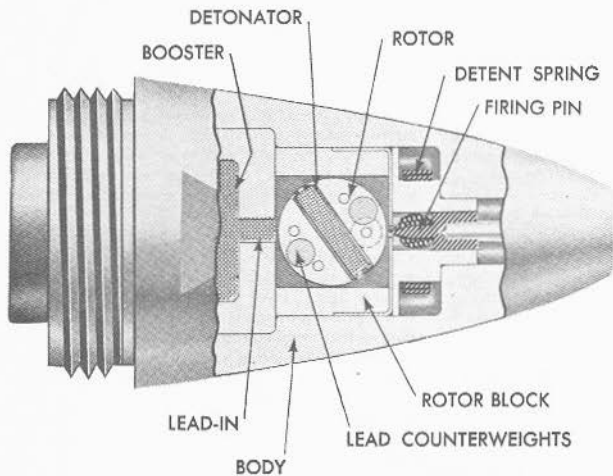
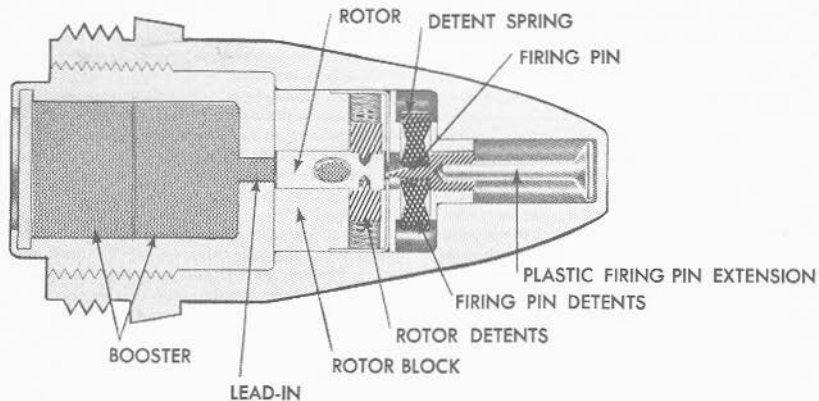

FIGURE 3E2.—Two views of point detonating fuze—unarmed.

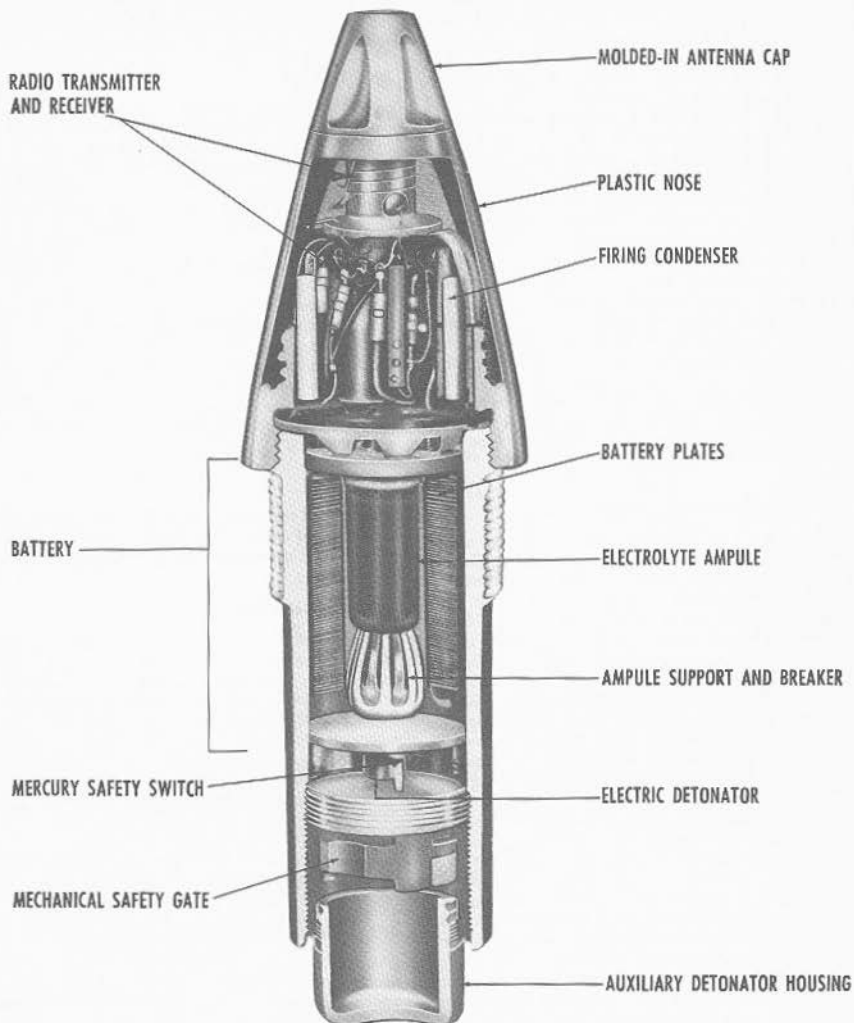

FIGURE 3E3.—Typical VT fuze.

primer consists of a small container of black powder which is fired by an electrical current passed through a resistance wire. The blast from this primer operates an auxiliary detonating fuze, which sets off the main explosive charge in the projectile.

This fuze, the result of Navy research, has been regarded as one of the greatest forward steps in recent ordnance development. It eliminates completely the tremendous problem of fuze setting in order to time the burst at a point in the trajectory where lethal damage results to a fast-moving target. This allows maximum concentration on accurate tracking and solution for the correct trajectory, which is necessary because the projectile must be placed within 100 feet of the target for the fuze to function.

VT-fuzed ammunition is very effective on exposed personnel and lightly armored targets ashore. It is also well adapted for harassing and interdiction fire to deny the enemy the use of, but not destroy, bridges and other works which our own forces may later require. No matter what the topographic configuration, the fuze will detonate at that designed point in its flight in close proximity to a reflecting mass, such as the earth or trees, where fragmentation blankets a maximum

effective area. The introduction of this fuze in the European campaign of World War II by United States Army artillery had a tremendously demoralizing as well as destructive effect on enemy ground troops.

### 3E9. Tracers

It is sometimes advantageous to follow a projectile in flight. For this purpose a tracer body is installed in the base or as an extension to the base, of the projectile. It contains a pyrotechnic mixture designed to burn with a definite color during all or a specific part of the projectile's flight. Standard tracer colors in the Navy are red or white in AA projectiles and orange (for night tracers) in AP and common projectiles. The tracer is ignited by the heat or pressure of the propelling charge.

In 40-mm projectiles, tracers perform the special function of setting off the burster charge at the end of the tracer burning period. This is accomplished simply by allowing the inside end of the tracer to have direct access to the main charge. The advantage of a *self-destructive* feature in AA projectiles, which might otherwise land and burst on own ships or installations, is obvious.

## F. Bombs

### 3F1. Bombs and bomb components

The aerial bomb provides for very efficient use of the load-carrying ability of a given plane. Only a small fraction of the weight involved must be reserved for suspension, release, and sighting equipment. On the other hand, an aerial bomb has very low initial velocity, this velocity being that of the airplane carrying the bomb at the time of release. Time of flight is relatively prolonged, and accurate computation is required to obtain hits. A partial exception exists, of course, in glide bombs with homing mechanisms. The first aerial bombs were the small, hand-thrown missiles of World War I, but 2-ton bombs are now commonplace, and even larger sizes have been standardized.

A conventional aerial bomb has three major components. The *body* contains the explosive charge, or it may have a chemical filler. The *fin assembly* is provided to keep the bomb stable in flight. A *fuze* serves to detonate the charge. These three elements usually are assembled into a complete round just before the bomb is loaded in or on the aircraft. A glide bomb, which is a guided missile, must in addition carry the equipment necessary for guidance.

Trends in bombing developments include the perfection of a great variety of special-purpose bombs, including some relatively small types and others of great weight; development of improved methods of tracking, sighting, and computing; development of

sighting and control systems that are effective at high altitudes and under all conditions of visibility or lack thereof; and evolution of more effective methods of detonation.

### 3F2. Bomb classification

In terms of their fillers there are three general types of bombs: *explosive* bombs, *chemical* bombs, and *inert* bombs. Varieties of explosive bombs include armor-piercing, semi-armor-piercing, general-purpose, light-catch, depth, fragmentation, and antiaircraft types. Chemical bombs include gas, smoke, and incendiary varieties. Inert bombs contain no explosives or chemicals, and are used in drills and in practice bombing. A number of aerial bombs are shown in figure 3F1. All bombs are painted with appropriate identifying markings.

In addition to the three major types, various encased pyrotechnic materials (not strictly bombs) are usually regarded as bomb ammunition.

### 3F3. Explosive bomb types

*Armor-piercing bombs* (fig. 3F2) are thick walled, contain about 15 percent by weight of explosive filler, and are intended for use against heavily armored ships and heavy steel or concrete structures. They incorporate only tail fuzes. The effect of a near miss with such a bomb is small, because of the small per-

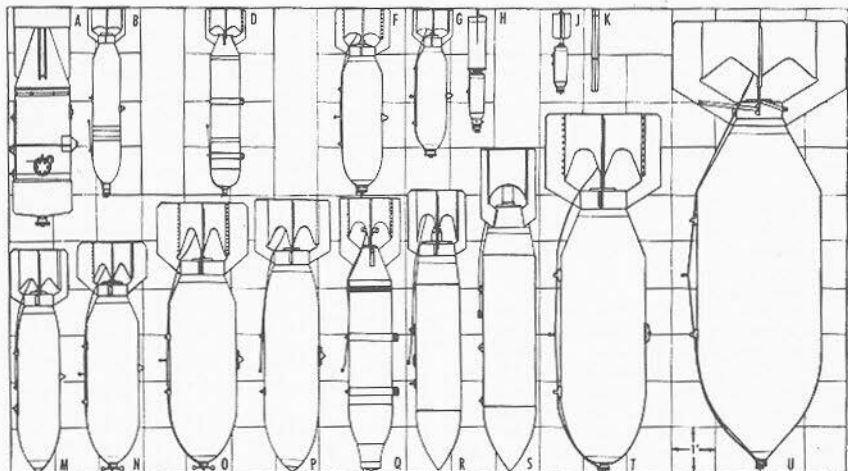

- A. DEPTH BOMB, 325-lb., FLAT NOSE
- B. GAS BOMB, 115-lb.
- D. CHEMICAL BOMB, 100-lb.
- F. G.P. BOMB, 250-lb.
- G. G.P. BOMB, 100-lb.
- H. FRAGMENTATION BOMB, 23-lb.

- J. FRAGMENTATION BOMB, 20-lb.  
(for cluster)
- K. INCENDIARY BOMB, 4-lb.
- M. S.A.P. BOMB, 500-lb.
- N. G.P. BOMB, 500-lb.
- O. G.P. BOMB, 1000-lb.

- P. S.A.P. BOMB, 1000-lb.
- Q. A.P. BOMB, 1000-lb.
- R. A.P. BOMB, 1000-lb.
- S. A.P. BOMB, 1600-lb.
- T. G.P. BOMB, 2000-lb.
- U. LIGHT CASE BOMB, 4000-lb.

FIGURE 3F1.—Types of aerial bombs.

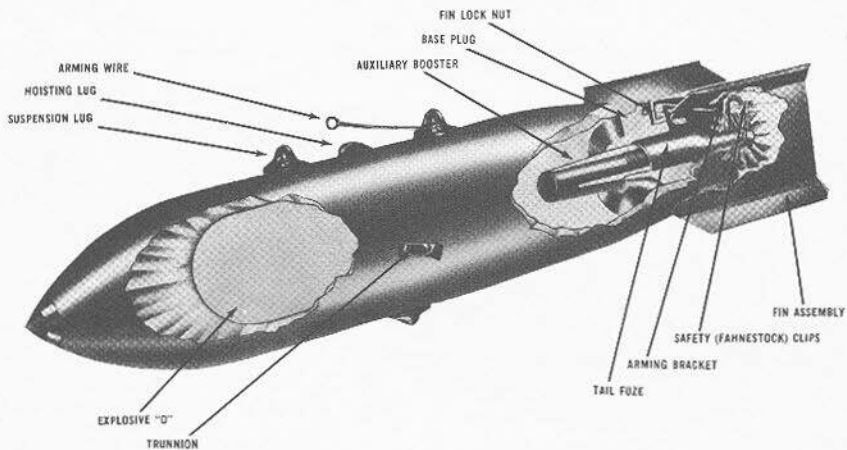

FIGURE 3F2.—An armor-piercing bomb assembled for loading.

centage of explosive contained. If used against unarmored or lightly armored ships, they are likely to pass clear through the target before detonating.

*General-purpose bombs* (fig. 3F3) have medium-thick cases, contain about 50 percent by weight of explosive filler, and are used to produce blast, fragmentation, or mining effects. Appropriate targets include unarmored vessels, submarines, and land targets such as ordinary buildings, aircraft (on ground), gun emplacements, and personnel.

*Light-case bombs* carry a maximum explosive charge: about 75.6 percent by weight. The fuzes used function instantaneously; this is necessary, because cases rupture upon impact. Various weights have been developed, ranging from 400 to 12,000 pounds. The effect of such bombs depends largely upon blast, and to a lesser degree upon fragmentation; they are effective against light structures and personnel.

*Depth bombs*, intended primarily for attacks upon submarines, contain about 70 percent by weight of explosive filler, and have relatively light cases. As shown in figure 3F1, a depth bomb has a flat nose to reduce the possibility of ricochets when it is dropped into the water at small entrance angles. For attacks upon submarines, this bomb is fitted with a hydrostatic tail fuze, but an impact nose fuze may also be installed if the target is a surface ship. If a nose fuze is present, it must be unarmed in making antisubmarine attacks. Depth bombs have little penetrating power, and depend primarily upon blast to produce desired effects.

*Fragmentation bombs* have heavy cases made up of

steel rings or steel bars, and contain about 14 percent by weight of explosive charge. When such a bomb bursts, fragments from the shattered case are thrown outward at high velocity and may do considerable damage to light installations, aircraft on the ground, unarmored vehicles, and personnel.

#### 3F4. Fire and incendiary bombs

Fire and incendiary bombs are types of chemical bombs. Large fire bombs may be droppable fuel tanks filled with a highly flammable mixture, which is usually 94 percent of 80 or 100 octane gasoline and 6 percent napalm. Napalm thickeners gel the gasoline to a rubbery mass of such a consistency that when used in the fire bomb the resulting conflagration covers a large area, burns intensely, and lasts a long time.

As an antipersonnel weapon, the fire bomb has been found to be effective against personnel in slit trenches, dugouts, and foxholes. As an incendiary, the fire bomb has been found to be effective against wooden piers, houses, docks and waterfront warehouses, wooden surface vessels, ammunition dumps, truck convoys, and any other readily burnable target.

The average coverage from one bomb dropped on level terrain is about 300 feet long and 100 wide, when dropped from aircraft in level flight at altitudes of 100 feet and speeds of 300 knots. Higher altitudes and lower speeds decrease the coverage and *vice versa*.

Other incendiary bombs usually contain thermite in magnesium alloy cases. As the thermite burns, the magnesium case becomes ignited and adds to the incendiary effect.

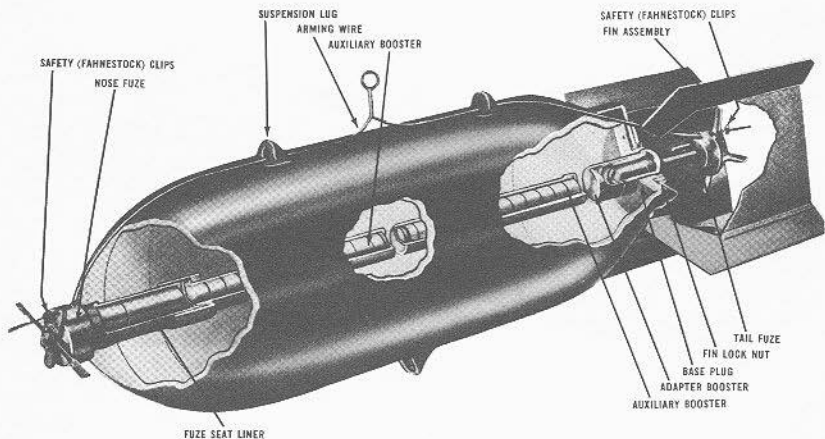

FIGURE 3F3.—A general-purpose bomb assembled for loading.

# ARMOR AND PENETRATION

## A. Types of Armor

### 4A1. Early ship armor

The idea of sheathing ships with projectile-resisting metal undoubtedly existed before any attempt was made to put it into practice. It is reported that a Korean admiral used ironclads in the late 16th century. The first European proposal to do so was made by Sir William Congreve in England in 1805, but the first ironmaster to make the attempt was John Stevens of Hoboken, N. J., some 7 years later.

Stevens' efforts did not meet with immediate success, but it does not appear that his approach to the subject was unscientific, for he had experimented until he knew the exact thickness of iron plate which would withstand the fire of any given gun. About 30 years after Stevens began the work, his son, Robert L. Stevens, felt that the work was far enough along to report the result to Congress. Yet another 12 years elapsed before Congress authorized the building of an armored floating battery. Meanwhile the French and the British laid the keels for a number of armored ships. In the bombardment of the Kinburn forts during the Crimean War, three French armored craft first demonstrated their usefulness.

The widespread interest in armored ships was probably due to the fact that the rifling of the barrels of long-range guns was also occupying the attention of naval designers. The spin-stabilized bullet had been used in small arms for some time, and it was felt that a similarly designed long-range gun was feasible. Such a gun was developed, and by the last quarter of the 19th century, smooth-bore ordnance had disappeared from use in the navies of the civilized world.

### 4A2. Iron armor

Although other metals were considered, only iron, wrought or cast, seemed feasible as a protective covering; and of these, wrought iron showed itself to be superior. The first practical armor consisted of 4- or 5-inch wrought-iron plate, backed by 36 inches of solid wooden timber.

The iron industry of the time, however, was not equal to the production of the necessary heavy forg-

ings. Therefore, even though early experiments had established solid plate as better than a built-up covering of laminated armor, naval designers were obliged to use plate built from thin layers, often inadequately bonded together. The armor of the Civil War ironclads was of this type.

The problem before the armorers of the day was quite clear: to produce a very hard face plus a very tough back. However, methods of providing sound cementation between a hard faceplate and a thicker, heavier foundation were still to be discovered.

### 4A3. Steel armor

Before any process for the production of such bonded armor was developed, the Bessemer converter, followed a few years later by the Siemens-Martin open-hearth process, changed the course of development. The French, in 1876, produced a 22-inch mild steel plate (which is said to have been hammered to that dimension from a thickness of 7 feet) that resisted the fire of all guns then in use. It was the best armor produced up to that time, but its tendency to crack led to a return to research in built-up armor.

### 4A4. Compound armor

The next advance resulted from the development of two rival processes. The first was the Wilson-Cammell compound plate which consisted of an open-hearth steel face cast on top of a hot wrought-iron back plate. The second was the Ellis-Brown process of cementing a steel face to an iron back by pouring molten Bessemer steel between them. In both cases, the plates were rolled after compounding.

Actually, only a small advance had been made. All the efforts of the steel men and Naval designers had amounted to a mere 25 percent advantage: 10 inches of compound armor was only about the equal of 12½ inches of iron. It was some progress, but not much.

### 4A5. Nickel-steel armor

French engineers again took the next step forward when, in 1889, Schneider introduced about 4 percent

of nickel into his steel plate, which increased its strength and toughness. His plate was hammer-forged, annealed, tempered, oil-quenched, and then reannealed. This new process added another 5 percent of resistance to the 25 percent already gained by the makers of compound plate. This type of plate was used by the United States to protect the old battleships *Texas*, *Maine*, and *Oregon*.

#### 4A6. Harvey armor (carburized nickel steel)

The next important development was American and, oddly enough, also originated in New Jersey, not far from the Stevens plant where protective plating for naval craft had had its beginning about 80 years before. In 1890, H. A. Harvey, of Newark, invented a process which added about 15 percent more strength to the plate described above. The new method consisted of *carburizing* the face of a plate of nickel steel by holding it at about the temperature of molten cast iron for 2 or 3 weeks with the face in contact with bone charcoal. This increased the carbon content of the outer inch of the face from about one-fifth of 1 percent to slightly more than 1 percent. The entire plate was then quenched, first in oil and then in water, and the result was both a hardening of the face and a toughening of the back. Later, the water dipping was replaced by cooling with a dense, high-pressure water spray.

It was soon found that this type of plate could be reformed at a low temperature after carburizing, reducing its thickness by from 10 to 15 percent without loss of strength. The resultant plate had the strength of iron armor half again as thick as itself.

#### 4A7. Krupp armor (carburized nickel chrome alloy steel)

The hardening effect of adding chromium to nickel steel had been discovered before the above develop-

ment was completed, but the resultant alloy was too difficult for the industry to handle until the Germans discovered suitable methods. Krupp at that time used illuminating gas as a carburizing agent instead of bone charcoal, but the industry at a later date returned to the use of a solid carbonaceous material for this purpose.

#### 4A8. Krupp armor (decrementally hardened)

The important *decremental hardening* process was introduced by Krupp shortly after the development of carburizing. The Krupp armor was processed by burying the plate, all but the face to be hardened, in clay, and exposing the face to a high, quick heat. This heat traveled from the face of the plate toward the back in an evenly descending plane, and when the critical heat for hardening had penetrated to from 30 to 40 percent of the thickness, the plate was removed to a spray pit and chilled by water played at first on the face alone and, a few moments later, on both sides of the plate together. This decremental face-hardening, as it was called, is still the general process by which modern protective armor is produced, though further refinement of the method constantly goes forward. This process may be applied to carburized or noncarburized armor as a final treatment.

#### 4A9. Class A armor

The carburized face-hardened plating described in the foregoing article is known as Class A armor. Its use is protection of the *vertical* surfaces around the more vital parts of heavily armored ships—the sides, the turrets, the barbettes, etc. The impact of a projectile against such surfaces would necessarily be at a very small angle of obliquity<sup>1</sup> and as such would have

<sup>1</sup>The angle of obliquity is measured between the axis of the projectile and the normal to the plate at the point of impact.

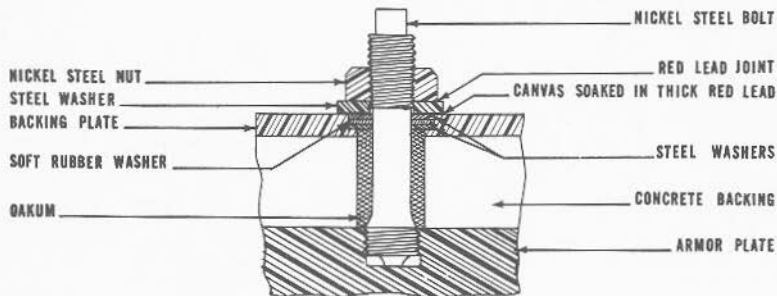

FIGURE 4A1.—Watertight armor bolt, showing interlocking use of resistant and yielding materials.

to be withstood by a very hard face to resist the initial impact, plus great backing strength to absorb the shock. Class A armor must defeat a projectile by stopping it, by breaking it up, or by rupturing the explosive cavity (thus reducing its effectiveness even though it penetrates the plate). Such armor must be of considerable weight, and naval design admits of the use of only a limited quantity of it. Enclosing the hull of a ship with heavy armor not only does not add to the strength of the craft, but actually diminishes it, for the great mass, affixed to the framing members and other strong points, complicates the stresses. For that matter, all armor represents dead weight, and naval designers must balance the requirements of essential protection against dead weight.

Class A armor can be machined only with difficulty, and cannot be fitted snugly against the skin of a ship. The accepted method is to suspend it from the strong points of the hull by means of extended watertight bolts (fig. 4A1) which allow about 2 inches clearance between the armor and the hull, and then to fill the space with concrete. Abutting edges are keyed together, and plates which meet at an angle are rabbeted (fig. 4A2).

The chemical analysis of a typical modern plate is about as follows:

Carbon .....	0.33%
Nickel .....	3.33%
Chromium .....	2.00%
Manganese .....	0.30%
Silicon .....	0.07%
Phosphorous .....	0.016%
Sulphur .....	0.02%
Iron .....	93.93%

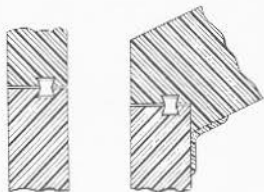

FIGURE 4A2.—Method of keying adjacent plates of Class A armor. Butt joint is shown at left—angle joint at right.

#### 4A10. Class B armor

Armor designed for the protection of horizontal surfaces, and otherwise, where the anticipated angle of obliquity is great, is physically quite different, although chemically about the same. Here, instead of boldly meeting force with resistance, advantage can be taken of the tendency of a projectile to *ricochet*. This glancing rebound is best achieved when the impact of the projectile is met with a plate that gives slightly, thus spreading the force over a wider area. Moreover, the curvature of the depression induced by the impact tends to pick up the curvature of the ogive, further inducing the projectile to rebound harmlessly away by increasing the angle of obliquity immediately after the instant of contact. (See fig. 4A3.) Homogeneous armor can be used in this application.

Homogeneous armor is not face-hardened. In thicknesses 3 inches and less, it is called "STS" (Special Treatment Steel). In thicknesses greater than 3 inches, it is termed class B armor. It can be inte-

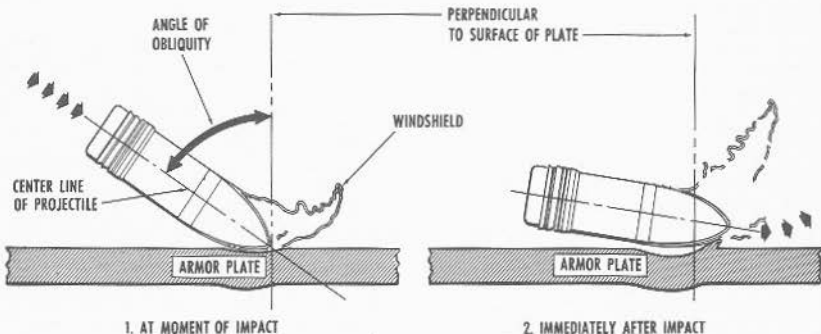

FIGURE 4A3.—Diagram showing left, angle of obliquity at instant of contact with Class B armor, and right, augmentation of same immediately afterward.

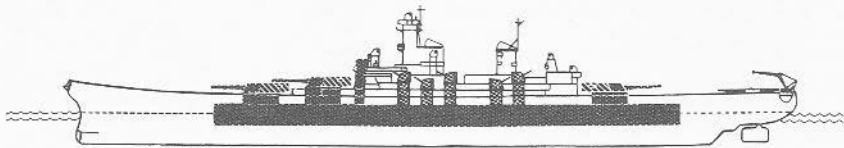

FIGURE 4A4.—Arrangement of Class A armor on a battleship.

grated with the structure of the ship, but it complicates the problem of weight, since it is heavy and lies high in the ship's structure, thereby shifting materially what would otherwise be the ship's normal center of gravity.

#### 4A11. Miscellaneous armor

Two minor classes of armor are *cast* and *light*. In the present state of its development, cast armor is not very satisfactory. It is used at points where plate-armor would be difficult to fit, such as turret range-finder end windows and sight hoods; attempts have been made to use it for boiler uptake grating plates. It has a future, because of the facility and speed with

which castings can be manufactured, but metallurgical advances must take place before extensive use can be made of it.

Light armor is a rough designation for any armor less than 2 inches thick. It is for the most part constructed like heavier armor, though some is compounded armor consisting of a hard face fused to a tough back. Its prospective usefulness as a protection for aircraft personnel and engines makes this one of the most important fields of ballistic research. Weight, however, is again a limiting factor.

Nonferrous armor (of aluminum alloy) can be used to protect against fragments. And plastic armor may be used for personnel.

## B. Penetration

### 4B1. Introduction

The same advances in metallurgy which contributed to the development of armor plate have proved to be equally useful in the manufacture of guns and of projectiles, particularly those designed to penetrate armor. The increased toughness effected by alloying steel with chromium and nickel, as well as improved methods for producing and forging large ingots, have resulted in better guns and in a race for supremacy between the designers of protective armor and the designers of projectiles to defeat the armor.

Armor plate is carburized to extreme surface hardness, whereas guns and projectiles, which must combine toughness with elasticity and heat resistance, are not. Steel used in the manufacture of guns usually contains molybdenum, an alloying element which imparts strength at high temperatures.

### 4B2. Projectile steel

Steel used in projectiles designed to penetrate armor is of the same general formula as Class A armor but with a higher carbon content. After rough forging, the projectiles are annealed, then rough-finished and again heat-treated. Decremental hardening is achieved by dipping the noses in melted lead and cooling them with water, this process being repeated twice. The result is a very hard nose and a tough, ductile body, this last characteristic being necessary to keep

the projectile from being broken up by the violent transverse stress caused by crashing through armor plate at an angle.

### 4B3. Armor-piercing projectiles

This term is used to designate the projectile designed to be used against armor plate of about one-caliber thickness. It must penetrate this plate with its bursting-charge cavity intact so that, when detonated by its delay fuze, it may produce high-velocity fragments within the ship.

For stabilization in flight, the center of gravity of a projectile must be just abaft the midpoint of its axis; but to effect proper penetration, an armor-piercing projectile should have the great mass of its weight immediately behind its blunt nose. Figure 4B1 shows how these two conflicting characteristics are reconciled by fitting a light, tapered *false ogive* or *wind-shield* over the heavy front end.

Within the false ogive, soldered and peneled to the nose of the projectile proper, is an armor-piercing *cap*. Made of the same steel as the projectile, the cap is hardened, but by a single immersion in molten lead. This cap serves several purposes: it is so shaped that it increases the *biting angle*; that is, the angle at which the projectile will penetrate instead of ricocheting; it spreads the shock of impact over the periphery of the nose instead of allowing the initial contact to batter

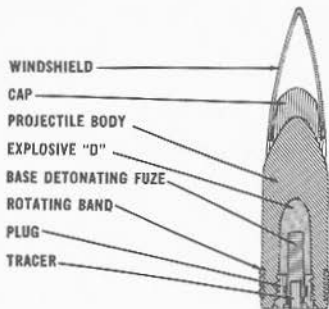

FIGURE 4B1.—Armor-piercing projectile.

the nose tip; and it prestresses the armor plate upon impact before the cap shatters away and allows the projectile to penetrate the weakened plate.

Projectiles of this type are not efficient against lightly armored ships, because of the relatively small bursting charge that they are able to carry. Because of the delay feature incorporated in their fuzes, they have been known to pass entirely through unarmored craft without bursting.

#### 4B4. Common projectiles

The common projectile is for use against lightly armored ships, being designed to pierce plate of  $\frac{1}{8}$ - to  $\frac{1}{2}$ -caliber thickness. It resembles the armor-piercing projectile except that it has thinner walls and can, therefore, carry a larger bursting charge. It has, instead of an armor-piercing cap, a hood, which provides a means of attaching the windshield without weakening the projectile body by cutting threads. The hood, like the cap, is soldered and peened to the projectile nose. See figure 4B2.

#### 4B5. Ballistic tests

Tests of both armor plate and projectiles consist of firing the latter against the former at measured striking velocities and at specified angles of obliquity. The projectile to be tested must be tried against armor plate of known resistance; or, if the armor plate is to be tested, the characteristics of the projectile must be known. The *penetration test* in each case is a measure of the striking velocity at which the element being tested will defeat the standard element. In testing, armor plate must withstand a maximum velocity; projectiles must penetrate at a minimum velocity.

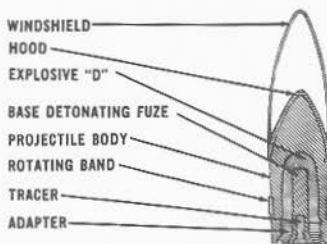

FIGURE 4B2.—Common projectile.

Certain terms must be defined to provide a basic picture of test procedure:

*Ballistic limit* or *limit velocity* is the striking velocity which will permit the projectile to pass completely through the plate and emerge from the back with zero residual velocity. Ballistic limit measures the true penetration resistance of the plate.

*Residual velocity* is the velocity of the center of gravity of the projectile at the instant the projectile emerges completely from the back of the plate.

*Complete penetration* is obtained when the projectile passes through the plate and emerges. *Incomplete penetration* describes any result less than complete penetration, and *partial penetration* describes the case of a projectile that breaks up, only a part of it passing through the plate.

The ballistic limit of a plate may be determined by any 1 of or a combination of the 3 following methods:

The *bracket method* consists of firing at varying velocities until an incomplete and a complete penetration are obtained within the desired small velocity difference or bracket. The ballistic limit is taken as the mean of the two velocities forming the bracket.

The *residual velocity measurement method* consists of firing one round at a velocity a little above the estimated ballistic limit and measuring the residual velocity, the ballistic limit being then computed by reference to established relationships between the residual velocity and the limit velocity.

The *penetration method* works in the opposite direction. A single round is fired at a velocity below the estimated ballistic limit and the depth of penetration measured, from which data the true ballistic limit is computed.

Armor plate is also subjected to shock tests, which measure the resistance of the plate to shattering or breaking up from the shock of projectile impact.

## Chapter 5

# ELEMENTS OF GUNS AND MOUNTS

### A. Introduction

#### 5A1. Development of guns

As the Foreword to this course indicates, guns have been used in warfare ashore and afloat for several hundred years. The Foreword indicates, in broad outline, how its effectiveness as a weapon has increased over this period of development. But this development has not been a slow, steady growth. For the first 400 years the technology of gunnery changed so little that, as the Foreword points out, one of Drake's men would have had to learn very little that was new to have served a gun at Trafalgar. Nearly all the basic features that have made the modern naval gun the effective weapon it is today have been developed within the past 130 years, and most of them began to become important only after the turn of the century.

Modern guns and mounts, with their associated sighting and fire control equipment, represent a highly developed technical level of achievement, not the less impressive because most of their features were initiated from 1 to 4 generations ago. Yet the guns and mounts aboard modern United States naval vessels, complex though they are in detail, are based on these relatively few fundamental features. Once they are grasped, the student will find it easier to master the details of structure and functioning of any gun mount or turret he encounters.

#### 5A2. Scope of this chapter

This chapter is devoted principally to those significant features of modern naval guns that have been

responsible for making of them the effective weapons they are today. Each of them is discussed individually in somewhat simplified form, with enough detail regarding its application to facilitate the student's understanding of operating principles when he encounters them in actual guns and mounts aboard ship. These features include:

1. Improved metallurgy and barrel construction.
2. Rifling.
3. Breech-loading mechanisms.
4. Percussion and electrical firing systems.
5. Recoil and counterrecoil systems.
6. Power rammers and mechanical ammunition feed.
7. Power-driven ammunition hoists.
8. Safety features—salvo latch, safety link, gas ejection.
9. Sighting and fire control equipment.
10. Power drives for elevating and training.

The next section of this chapter will take up first the common or *conventional* structural features of naval guns and mounts, then will discuss individually the characteristic structural and functional elements of modern naval gun mounts, as listed above.

The final section of this chapter presents, in summary form, fundamental definitions relating to guns and mounts.

### B. Features of Modern Naval Guns and Mounts

#### 5B1. Common structural features of naval gun mounts

Figure 5B1 is a closeup phantom view of a 5"/54 mount Mark 39. Though this particular mark is not the commonest of 5-inch mounts, it is a good example of the conventional type of mount that shows the features with which this chapter is particularly con-

cerned. It differs structurally from most other 5-inch mounts principally in having a longer barrel. There are other differences in power drives and hoist arrangements with which we are not concerned at the moment.

Besides showing (as a phantom) the shield which protects the mount, figure 5B1 shows also a number of the major mount components which are essential

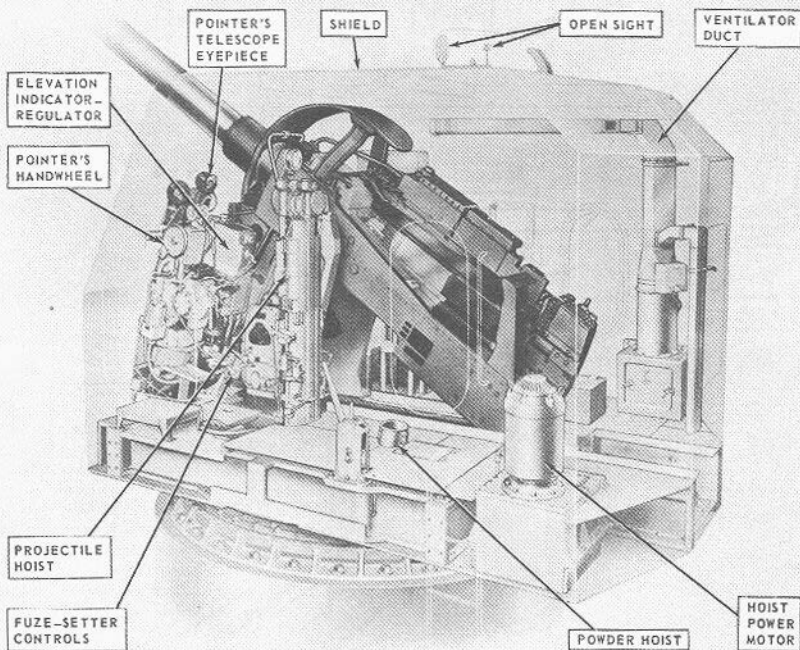

FIGURE 5B1.—Enclosed 5"/54 single mount. (Phantom view.)

to its proper functioning but are structurally accessories rather than basic parts. Such units pointed out in figure 5B1 include parts of the elevation controls and power drive (on the left side of this mount), the pointer's sight telescope, the mount captain's open sight (in the shield overhead), a ventilator duct (also in the shield), and parts of the hoists and fuze setter. On the other (right) side of the mount are the trainer's controls and power drive.

In figure 5B2 these accessory units are stripped away to reveal what might be considered the "skeleton" of the gun mount.

Serving as the mount foundation is the *stand*, a steel ring bolted to the deck. The *training circle* is an internal gear inside the stand.

Supported by the stand, and capable of rotating in train in roller bearings on it, is the *base ring*. It may also be called the *deep section ring* or *lower carriage*.

Mounted on it is the *upper carriage*, which is a pair of massive brackets braced to hold the *trunnion bearings*. The trunnion bearings are large roller bearings into which the gun trunnions fit. The trunnions are part of the *slide*, a rectangular weldment which supports all the elevating parts of the gun. The *housing* slides in recoil in the slide; the *barrel* fits into the housing's forward end, and the *breechblock* can slide up and down in a breechway just behind the barrel. Arrows show the movement of which each part named (except the breechblock) is capable.

Now consider these parts in further detail. Figure 5B3 shows how the lower carriage or base ring fits into the stand, and how the mount can move in train. Angle brackets called *holding-down clips* bolted to the base ring fit under the stand so that the carriage will not tip off the stand when the gun is fired or when the ship pitches and rolls. The base ring can turn

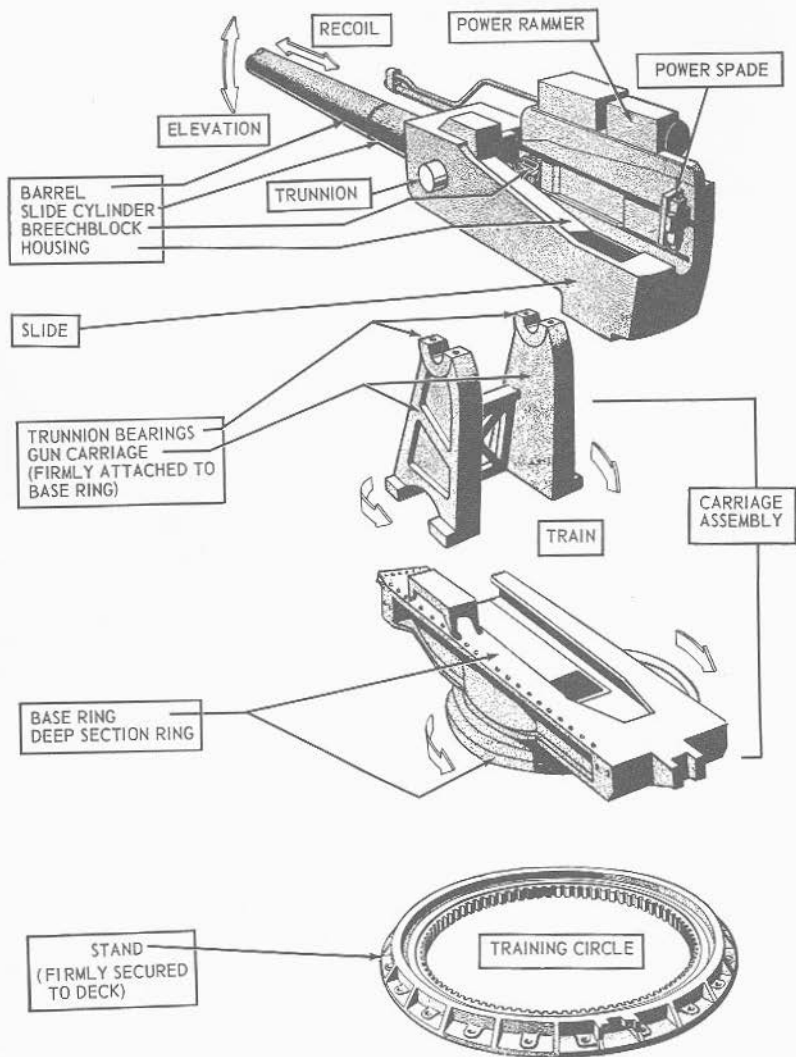

FIGURE 5B2.— Main assemblies of a 3-inch mount. (Exploded view.)

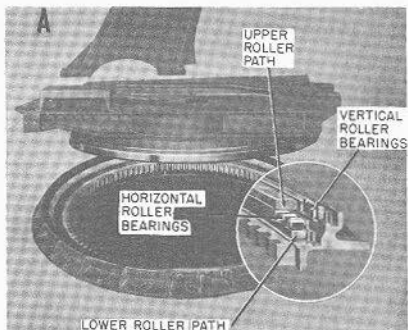

FIGURE 5B3.—Details of the stand and carriage. A. Roller bearings.

on the stand in two large-diameter roller bearings. One takes up vertical thrust; the other, horizontal. The function of the training circle is illustrated in figure 5B3; a pinion in the carriage engages the internal gear of the training circle to train the mount.

The carriage assembly is generally considered as two pieces—the lower carriage (base ring) and upper carriage—though on 20-mm mounts the distinction is unimportant. Figure 5B4 highlights these elements. The base ring supports the upper carriage, and the platform or working surface; the shield (in enclosed mounts) is secured to it. It also supports the mount power drives and other components. In mounts equipped with hoists, the hoists are suspended from the base ring and train with the mount. The upper carriage, which in 5-inch mounts may be called the carriage cheeks and in turrets is called the deck lug, is principally the support for the trunnion bearings (figure 5B4). The trunnion bearings and trunnions, in addition to serving as a support which permits the elevating parts to move in elevation, also provide a connection point for air lines (for gas ejection) and mechanical linkages (for mechanical firing linkages and for transmission of elevation movement to firing stop mechanisms).

The trunnions are a part of the slide (fig. 5B5), which is conventionally a rectangular steel weldment which houses or supports all the parts of the gun and mount that move in elevation. In modern mounts designed to engage either air or surface targets the limits of elevation movement are from minus 10 to 15 degrees (that is, with gun barrel depressed 10 to 15 degrees below the horizontal) to about plus 85 degrees (that is, with the gun barrel within 5 degrees of pointing straight up, at right angles to the deck). Because of

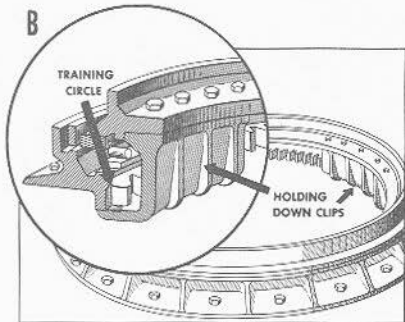

FIGURE 5B3.—B. Training circle and holding-down clips.

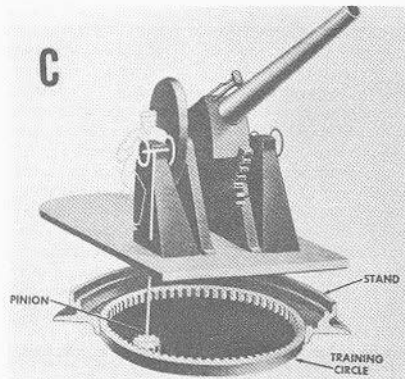

FIGURE 5B3.—C. Principle of training gear.

the limitations imposed by turret structure, elevating mechanism, and ammunition feed equipment, turret guns of older design are not capable of these extremes of elevation.

Figure 5B5 points up the slide and the elements of elevating gear. The slide contains the ammunition feed mechanism (or the power rammer where ammunition feed is performed manually with mechanical assistance), the recoil brake, the counterrecoil mechanism, the elevating arc, and the gun housing. The function of the elevating arc in positioning the slide in elevation is shown in figure 5B5. The arc is a gear sector secured to the slide. It engages a pinion in the carriage. The pinion may be driven manually or by an elevation power drive.

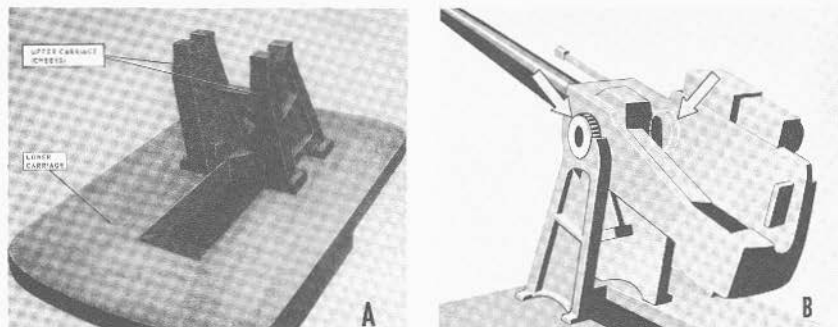

FIGURE 5B4.—The carriage. A. Upper and lower carriage. B. Trunnion bearings.

The recoiling parts (that is, those that move to the rear when the gun is fired) of a conventional naval gun are either attached to or are housed in the *gun housing* (also called the *breech housing*). The housing and related parts are highlighted in figure 5B6. (Some turret guns and 20-mm guns differ considerably from this type of conventional design, and this description is not intended to apply to them.) Secured to the forward end of the housing is the gun barrel itself. The commonest method of attaching gun to housing is by use of a *bayonet joint* or *interrupted-screw joint*, with a key to lock the barrel against possible rotation. The housing can move parallel to the gun bore axis in ways in the slide. It is normally forced to its forward-most position (called *battery position*) by a counter-recoil mechanism (not illustrated in fig. 5B6), which may be either a powerful coil spring or a pneumatic

device. When the gun fires, the reaction of the barrel forces the housing aft; this movement is opposed by the counter-recoil mechanism and by a hydraulic recoil brake (also not illustrated in fig. 5B6.) The counter-recoil and recoil mechanisms will be described and illustrated in a later article of this chapter.

Figure 5B6 also indicates the location and some features of the breech mechanism. The type used in most guns of conventional design, including the 5-inch, and illustrated here, is called the *vertical sliding-wedge* type. Further details of its construction and functioning principles appear later in this chapter.

### 5B2. Gun barrel construction

Superficially, the modern gun barrel resembles very closely its ancestor of several hundred years ago. The old and the new both are thick-walled metal tubes.

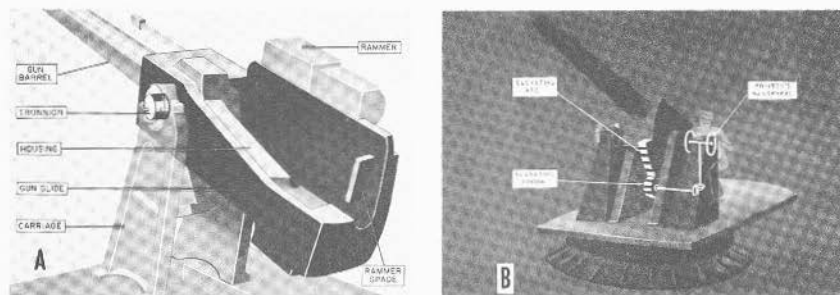

FIGURE 5B5.—The slide. A. Main features. B. Principle of elevating mechanism.

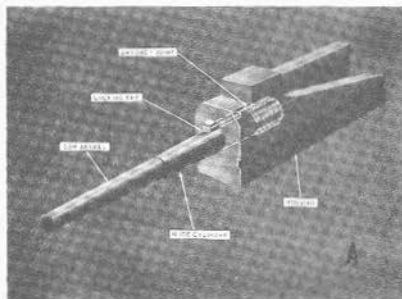

FIGURE 5B6.—A. How barrel secures to housing.

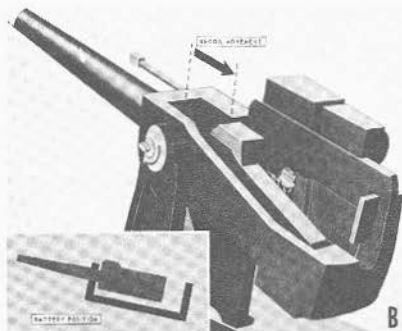

FIGURE 5B6.—B. Recoil movement.

The propellant charge and projectile occupy the breech end when the gun is loaded, and the projectile, when fired, issues from the muzzle end.

But with this the resemblance ends. Figure 5B7 shows in cross section the old look and the new in gun barrel profiles. The difference in shape is very significant. The figure also points out the main features of the contemporary gun barrel. Let us now consider these more closely.

1. At the breech end is a *plug or breechblock* which can be opened for loading the gun. Breechblocks take various forms; the illustration shows (as viewed from above) the general structure associated with the sliding-wedge type used in 5-inch mounts. Breechblocks will be discussed in further detail later. Early guns, except for a few custom-made small-arms weapons, were almost invariably muzzle loaders; breech loaders were rarities. Hence the silhouette representing the old gun shows no breech plug.

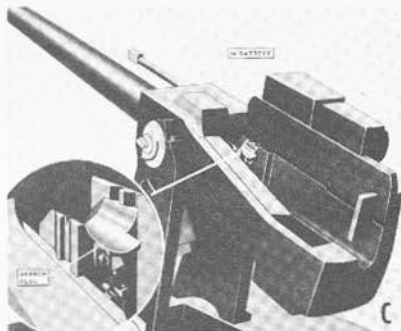

FIGURE 5B6.—C. Location of breech plug.

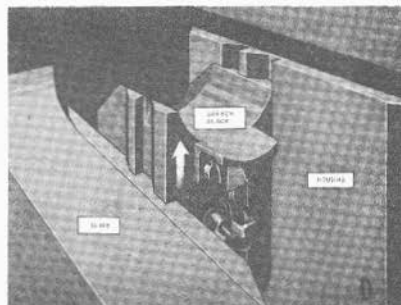

FIGURE 5B6.—D. Breechblock rising to closed position.

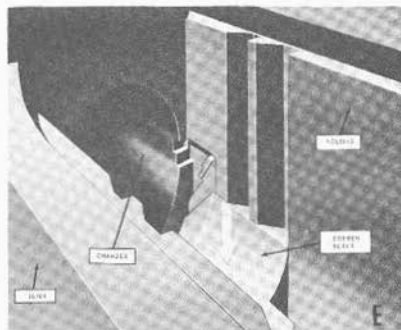

FIGURE 5B6.—E. Breechblock dropping to open position.

2. Just forward of the breech plug is an enlarged chamber to contain the propelling charge.

3. The bore is *rifled*—a set of spiral grooves twists the projectile as it moves toward the muzzle, so that it is spinning when it leaves the gun. Old guns as a rule were smoothbores. In newer types of larger guns, the rifling is cut in a *liner*—a tubular insert that can be replaced when worn. (Fig. 5B7 shows the rifling cut into the liner of an 8-inch turret gun of recent design. The liner reference marks are used for aligning the liner in the gun tube.) In other guns, the rifling grooves are cut into the barrel.

4. As compared with early guns, the barrel walls are much thinner in modern guns, and the taper is much less exaggerated. As will be explained, improved propellants and improved steels have together brought about this silhouette.

Common external features are pointed out in figure 5B7. Many guns have a *bell* at the muzzle, where the metal is made thicker to discourage any tendency to split. Most modern weapons lack a bell, or instead have *lugs*, which are utilized when the liner (see No. 3 above) is replaced. (The lugs serve to anchor the tool used for pulling the liner out.)

The thinnest part of the barrel, just aft of the bell, is the *neck*. Then comes the tapering *chase*, followed by the *slide cylinder*, which moves in a bearing in the slide during recoil. The after part of the barrel is secured to the gun housing. In the conventional 5-inch gun, the breechblock slides up and down in a grooved rectangular breechway in the housing.

Now consider what is between the exterior and the interior surfaces of the barrel—the steel itself. Looking at the profiles of guns old and new (fig. 5B7), it's evident that although both taper from a wide breech end to a narrower muzzle, the taper is much more drastic in the older weapon. Superficially, this difference in silhouette may seem a small matter, but it is actually very important. It indicates the revolutionary developments in propellants and in metallurgy that differentiate the new from the old.

Consider what happens when the propellant in a gun is ignited. As it burns, it turns to hot gas under terrific pressure—up to 60,000 psi in small guns, up to 40,000 psi in larger guns. As the projectile moves along the bore toward the muzzle, the gas pressure goes down. It follows, then, that the chamber wall should be the thickest part of the gun barrel, with the taper from breech to muzzle reflecting the decreasing gas pressure behind the projectile.

However, when black powder was the propellant, the chamber had to withstand the initial shock of this propellant's exceedingly rapid burning rate. Thus, before the projectile was well along the bore, the propelling charge had already developed its maximum

pressure as a sudden shock, and the gas pressure was falling rapidly. The breech had to be especially heavy to withstand the shock, but the tube was short because the gas pressure fell so rapidly. In modern guns using pyro or triple-base propellants, the maximum gas pressure is developed far more smoothly, and declines less suddenly. This is reflected to a great extent in the silhouette of the modern barrel.

The thinner barrel walls of modern guns are evidence not only of more effective propellants but also of improved metallurgy of the barrel. Before the '80's of the last century, the surest way to make the barrel of a gun withstand more pressure was to make it thicker. But there were limits to this method. Then it was discovered that by *prestressing*, it was possible to make a gun barrel more resistant to internal pressure. The earliest method of applying this principle was to heat steel ring-shaped jackets, or *hoops*, to high temperatures, then slip them over the gun tube and allow them to cool. As the hoops cooled, they contracted, until at the end of the process they were squeezing the gun tube inside with a pressure of thousands of pounds per square inch. Guns so constructed are known as *built-up guns*, and are still made in sizes over 8-inch.

About the time of World War I, the same principle was applied to monoblock (one-piece) guns in the *radial-expansion* or *autofrettage* process. In this process, a single steel gun tube whose bore is slightly smaller than the caliber desired is filled with hydraulic fluid. The pressure is then built up enough to enlarge the bore permanently about 6 percent. When the pressure is released, the outer layers of the tube tend to return nearly to their original dimensions, while the inner layers, which have been considerably enlarged, tend to maintain their increased diameter. The result is that the inner layers of metal are severely compressed by the contracting force of the outer layers, just as if a hoop or jacket had been shrunk on. In other words, the tube is "self-hooped."

The big advantages of the radial-expansion monobloc gun over the built-up type are simplicity of manufacture and comparatively low cost and weight. Because of the difficulty of working on the single huge forgings required for guns over 8-inch, though, larger weapons are still built-up. Or the two methods of prestressing may be combined.

### 5B3. Rifling

As the Foreword to this course explains, early guns were capable of hurling a projectile to a respectable range, all things considered. Large cannon could heave an iron or stone ball at a target a couple of miles away, and actually overshoot. But their fire was so inaccurate that a gun capable of an extreme range

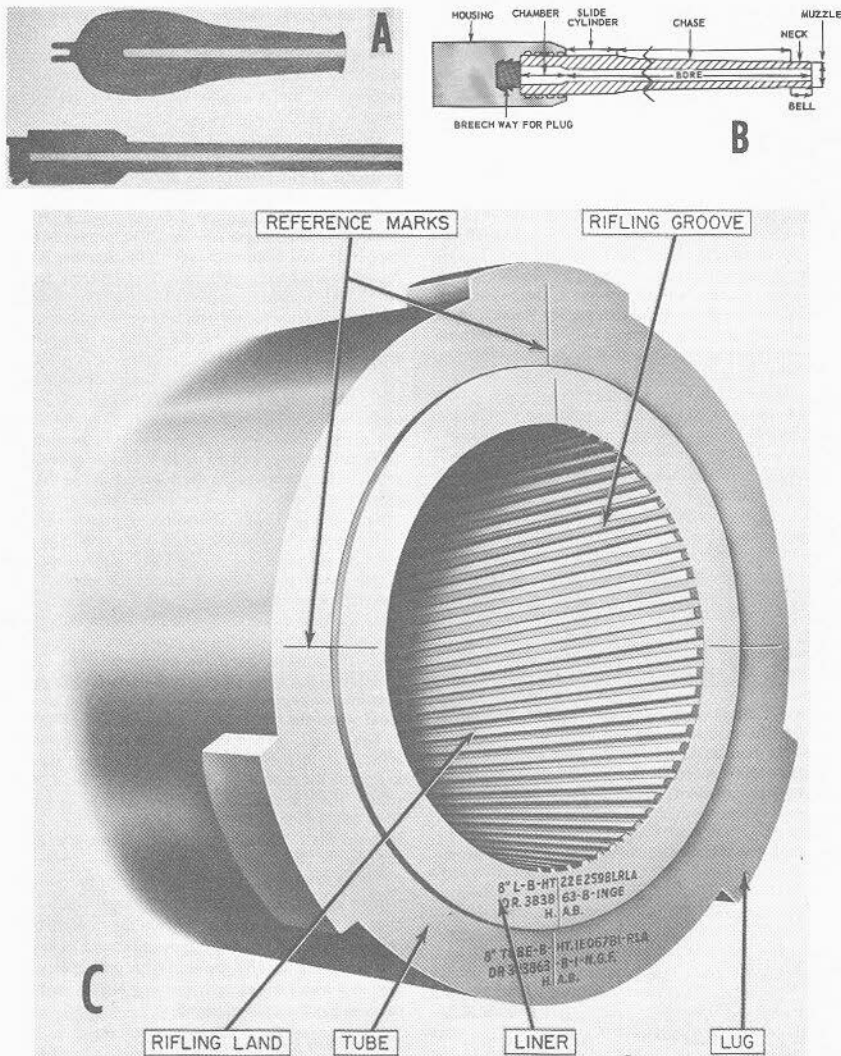

FIGURE 5B7.—The gun barrel. A. Old and new gun barrel profiles. B. Main parts of the barrel. C. Muzzle end of 8-inch turret gun, showing the rifling and the liner.

of about 2,000 yards was considered reasonably certain to hit its target only at point-blank range—in this case, up to 80 or 100 yards.

There were several reasons for this poor showing. One was that, other things being equal, a light projectile will travel a lesser distance, and be more affected by wind and air resistance, than a more massive one. Since these old smoothbore cannon could fire only round shot (and the maximum volume of a sphere is rigidly determined by its radius), it was difficult to make the projectile sufficiently massive. An elongated projectile could, of course, be made more massive by making it longer. But unless it can be made to spin around its long axis, an elongated projectile has, as some ballisticians put it, the ballistics of a brick, and its flight path or trajectory is much more erratic than that of a spherical one. Hence, because a smoothbore cannon cannot make its projectile spin, round shot were the only alternative.

There were other reasons, too, for the inaccuracy of early gunnery. One standard method for loading the classical type of seagoing muzzle-loading smoothbore required the gunner first to ladle into the breech end of the bore a measured quantity of black powder (later, a paper- or cloth-wrapped "cartridge" was used), and then to ram down the bore the round shot wrapped in a fabric "patch." Since close clearances would have made loading impossible, the shot was a fairly loose fit. (See figure 5B8.) When the gun was fired (by lighting off a priming mixture which filled a "touch hole" leading into the blind breech end of the bore), the patch was supposed to seal the powder gases behind the loose-fitting ball projectile. But much of the gas would blow by one side or the other. The result was that a lot of the gas pressure was wasted because it didn't serve to propel the ball, and as the ball left the muzzle it was not likely to be traveling along the bore axis. Hence the ball was slow (300 fps was a likely speed, as compared with 2,700 fps in conventional modern naval medium-caliber guns), and its trajectory predictable only in the most general fashion.

Rifling the oldtime muzzle-loading cannon was im-

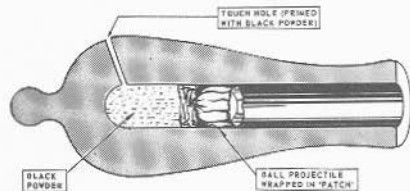

FIGURE 5B8.—Cross section of early naval gun (loaded and primed).

practicable because of the difficulty of ramming close-fitting ammunition down the length of the bore. Such ramming was possible only in small arms (which is why rifled shoulder weapons were used by infantry as far back as the American Revolution), but not in cannon.

Figure 5B9 illustrates how these problems are solved in modern conventional naval guns. First of all, the projectile is elongated, with an ogival forward end. Breech-loading permits an enlarged chamber which contains more propellant of a slower burning and less erratic type than black powder. The projectile has a copper or alloy rotating band. The chamber is connected to the bore proper by a short tapering forcing cone. When the projectile is rammed into the gun, the rotating band forcibly engages the forcing cone.

And the gun bore itself is different. It isn't smooth. It is grooved or rifled, and the grooving is helical or spiral. (Fig. 5B9). The rifling begins at the forcing cone and continues to the muzzle. In all naval guns and small arms except the .45 caliber pistol, the rifling has a right-hand twist. The twist may be uniform (generally around 1 in 15 or 20 times the bore diameter), or increasing (as in the 40-mm gun) so that the twist becomes sharper as it nears the muzzle.

The number, depth, and width of grooves varies in different designs. Small arms have relatively few grooves, and cannon (fig. 5B9) have a large number. Groove width may decrease toward the muzzle. The bore diameter or caliber of a rifled gun is measured from the top of one land (the high surfaces between grooves) to that on the opposite side of the bore. Since the rotating band for the projectile is slightly larger than the nominal gun bore diameter, the rifling cuts into or engraves the softer metal of the rotating band when the projectile is rammed, as can be seen in figure 5B9. When the gun is fired, the projectile spins at an increasing rate as the propellant gas forces it toward the muzzle. (With right-hand twist in the rifling, the direction of spin is clockwise as viewed from the breech.) Moreover, because of the close fit between the rotating band and the rifling it engages, the gas is effectively sealed behind the projectile. (This explains why rifling is made with grooves that narrow toward the muzzle; the grooves continue to engrave wider and wider notches in the rotating band, ensuring a tight fit as the projectile approaches the muzzle.) Figure 5B9 shows how a projectile might look as it leaves the muzzle, spinning rapidly and with rotating band deeply engraved.

#### 5B4. Breech mechanisms

A previous article has already noted that rifling was applied to small arms quite a long time ago. (Rifled

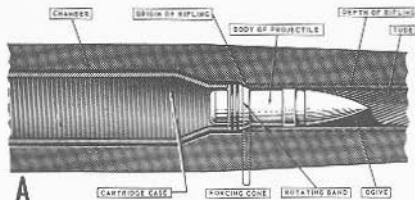

FIGURE 5B9.—A. Cross section of gun chamber (fixed ammunition).

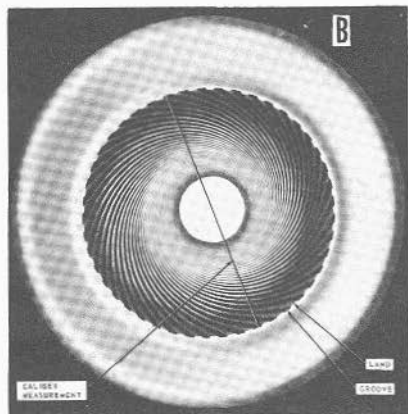

FIGURE 5B9.—B. Rifled bore (viewed head-on).

small arms were used in the American Revolution, and enabled American sharpshooters to stand at a distance and pick off the redcoats, whose smoothbore muskets were no match for the American rifles either in range or accuracy.) But it could not be applied in a practical way to artillery, either seagoing or ashore. Ramming large-caliber ammunition from the muzzle was excessively difficult if the projectiles fitted the rifled bore closely, and the rifling was useless if they didn't.

The key to making effective and practical rifled cannon lay in the development of effective and practical mechanisms to permit loading from the breech end of the gun rather than the muzzle.

With but one exception (which is discussed in volume 3 of this series of textbooks), all naval guns in present use in calibers 40-mm and larger use 1 of 2 general types of breech mechanism. One, which is used in bag guns only, is the *Welin interrupted-screw*

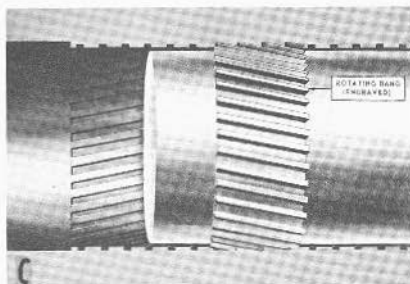

FIGURE 5B9.—C. The rifling engraves the rotating band.

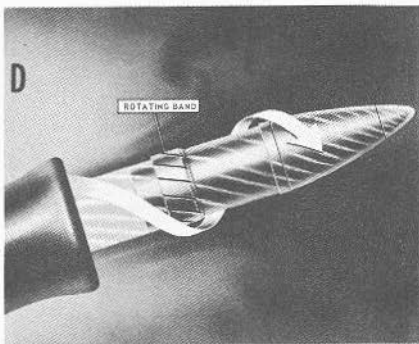

FIGURE 5B9.—D. Projectile spin during flight.

type. The other, used in 40-mm, 3-inch, 5-inch, and 6-inch guns, and in 8-inch turret guns for case ammunition, is the *vertical sliding-wedge* type. Consider the interrupted-screw type first.

*Interrupted-screw mechanism.* The screw is a widely used device for securing something against a heavy thrust. Figure 5B10 shows how a continuous screw closure might be used to seal the breech end of a metal tube to make a gun of it. Such a breech closure or plug would of course require unscrewing to open the breech after firing. The mass of such a device, designed to withstand the 40,000 psi gas pressure developed in a typical large-caliber cannon, would inevitably be considerable. (The breech plug of a 16-inch naval gun, for example, weighs about 1,400 pounds.) Turning such a screw through several revolutions would not be easy.

Application of the principle of the interrupted screw

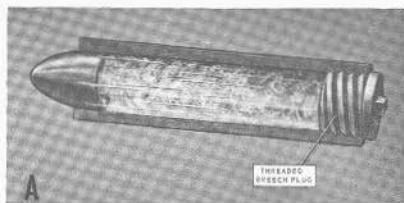

FIGURE 5B10.—Principle of the interrupted-screw breech-mechanism. A. Continuously threaded breech plug.

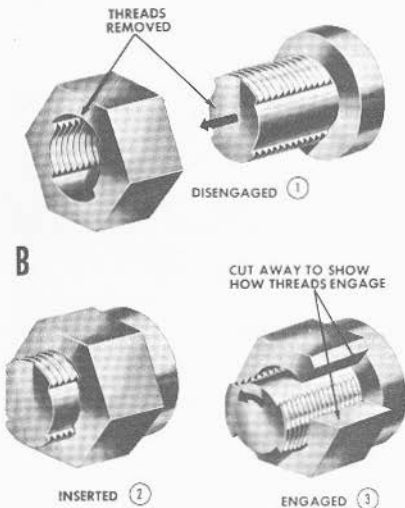

Figure 5B10.—B. Interrupted-screw bolt and nut.

reduces the number of turns required to a fraction of a revolution. If half the threaded area is removed from a bolt (representing the breech plug) and the nut (representing the breech or screw box), then it is possible to insert the bolt (1 and 2 in figure 5B10) and engage the two by turning the bolt  $90^\circ$  (3 in figure 5B10).

The disadvantage of this straightforward application of the interrupted-screw principle is that half the threaded area must be removed, and this reduces the "holding power" by reducing the amount of thread area that can be engaged. This disadvantage is partly obviated by the *Welin stepped-thread* breech mechanism. In this arrangement, both plug and breech have

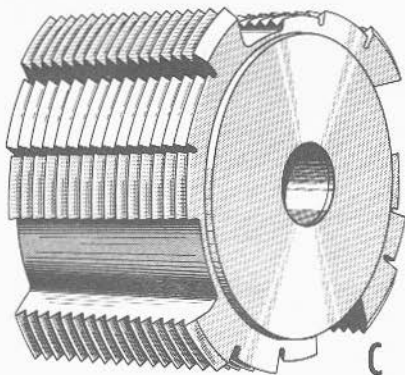

FIGURE 5B10.—C. Stepped-thread plug (Welin type).

*steps*. The steps are arranged in groups, with each group of four ascending (or descending) steps occupying one  $90^\circ$  sector. On the plug (figure 5B10), the lowest step of each group is blank, and the others are threaded. On the breech screw box the highest step in each group is blank, and the others threaded.

Figure 5B11 shows how an obsolete 14-inch breech mechanism functions in closing. The principle is the same on present-day 8-inch and 16-inch bag guns now in the Fleet, but in those ships the plug swings in a vertical arc (as in figure 5B12) rather than a horizontal one. Note that there are two distinct motions of the plug in opening and closing—a *trundling* movement in which the plug swings on a massive carrier hinged to the side of the breech, and a *rotating* motion in which the plug screws into the screw box. Both of these may occur together in the final stages of closing or the beginning of opening.

Now follow the breech-closing action as illustrated in figure 5B11:

1. From its open position, the plug swings around toward the screw box. As the plug moves in, each high threaded step of the plug fits into a low blank step of the screw box (fig. 5B11). The high threaded steps on the screw box fit into the low blank sectors of the plug. The other threaded steps also clear each other in this position.

2. When the plug is well into the screw box, but has not yet begun to rotate, a *cam roller* on the plug contacts a *camway* in the screw box. (Figure 5B11 shows how the plug must rotate to engage the screw box.)

3. During the last part of its translation into the screw box, the plug's cam roller engages the camway

**A****B****C****D**

FIGURE 5B11.—Interrupted-screw breech mechanism. Steps in closing.

and the plug turns so that the mating threads on box and plug engage. Figure 5B11 shows the breech closed, locked, and ready for firing.

Notice the two great advantages of the Welin-type screw box and plug:

1. About 75 percent of the engaging surfaces of plug and screw box are threaded.
2. The plug requires only about 27.5 degrees of rotation for full engagement and locking.

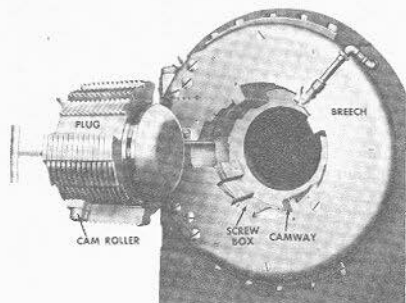
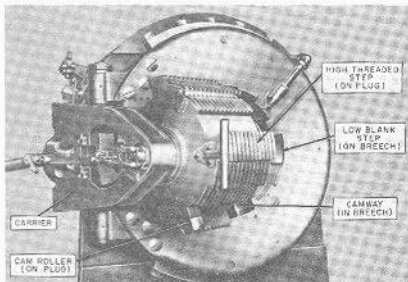
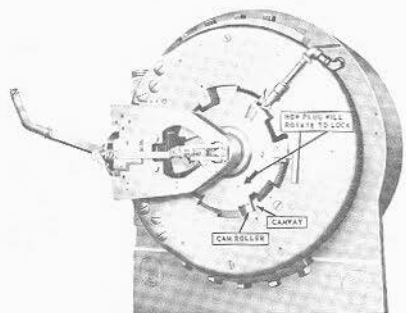
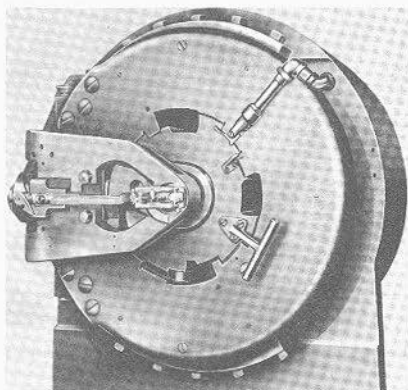
Compare these characteristics with the original bolt and nut, and you can see the improvement.

Welin-type breech mechanisms may have 3, 4, or even 5 steps, counting the blank sectors. In most modern installations, the plug swings vertically up into

the screw box (fig. 5B12) rather than horizontally as in the 14-inch breech pictured in figure 5B11.

Because of the large size of the guns on which they are generally found, interrupted-screw plugs are too heavy for unassisted operation by hand. (As noted above, on a 16-inch gun the plug may weigh as much as 1,400 pounds.) Interrupted-screw mechanisms for these large guns are therefore generally fitted with air- or spring-powered devices to aid the gun crew in operating them. These devices will be discussed further in chapter 7 on turrets.

The discussion of the interrupted-screw type breech mechanism so far has concentrated on the principles of operation of the engaging parts—the plug and



FIGURE 5B12.—Interrupted-screw type breech mechanism (16-inch) now used in the Fleet.

screw box. There remains one other important function for this type of breech mechanism to perform. Besides withstanding the brute thrust of the high-pressure propellant gas in the chamber during firing, it must also prevent *leakage* of the burning, toxic gas into the turret or mount. It does this by means of an obturator or sealing device—the *DeBange gas-check system*.

The DeBange gas-check system is used in all United States Navy bag guns. Its main parts are the *mushroom*, *gas check pad*, *split rings*, and *gas check seat*. Figure 5B13 shows a typical gas-check assembly.

The biggest component is the mushroom. (In a 16-inch gun it weighs 220 pounds.) It consists of a large flat steel head at the forward face of the plug, with a long steel stem extending through a hole in the plug and protruding from its rear face. Through the center of the stem and head passes a hole called the

*primer vent*. The primer fits in a primer chamber in the after end of the mushroom stem. (The primer vent does for the modern bag gun what the touch hole did for its ancient counterpart.)

Between the mushroom head and the forward face of the breech plug, and bearing against a smooth section of the breech chamber called the *gas-check seat*, is the *gas-check pad*. This is a thick flat resilient doughnut-shaped disc of plastic, whose outer and inner edges are protected from wear by steel split rings. The system works this way:

1. When the gun is loaded and the breech plug is closed, the ignition charge in the powder bag (not shown in figure 5B13) is right up against the mushroom head. (The ignition charge is composed of black powder. When the ignition charge explodes, it sets off the smokless powder which comprises the bulk of the propelling charge.)

2. The primer is in the primer chamber. When the gun is fired, the primer goes off, sending a hot flame down the vent in the mushroom stem. That ignites the black powder ignition charge, which in turn sets off the smokless powder.

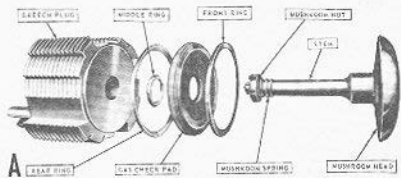

A

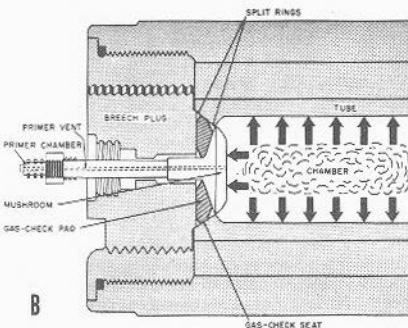

B

FIGURE 5B13.—DeBange gas-check system. A. Exploded view. B. Cross section, showing operations.

3. As the powder burns, the expanding gases push hard against all sides of the breech chamber, the projectile, and the mushroom head. The only thing that can yield is the projectile, which begins to move up the gun bore.

Meantime the pressure goes higher and higher up to 40,000 psi until the projectile is fully under way, when the pressure tapers off.

4. As the pressure increases, it shoves the mushroom head hard back against the gas-check pad. The pad expands against the gas-check seat, effectively sealing the breech against the escape of gas. And note this feature of the device—the greater the gas pressure, the harder the mushroom compresses the pad against the gas-check seat.

**Vertical sliding-wedge breech mechanism.** The interrupted-screw type of breech mechanism has its advantages. Since it has its own obturator mechanism, it can use propelling charges in silk bags which are consumed in firing, and once the bore is cleared of residual gases and burning fragments, the next round can be loaded without requiring extraction and disposal of the used container for the fired propelling charge. It can also be used (though the U. S. Navy has no guns of this type in active service at the present time) to fire case ammunition.

But this kind of breech mechanism also has disadvantages. One is really to be ascribed particularly to the nature of the ammunition itself. Because of the fire hazard, a crewman must inspect the chamber after each round fired to ensure that it is safe to load the next round. This slows the rate of firing. More important, this kind of breech mechanism is complex in operation. Coupled with the number of separate ammunition details that must be handled per round (totaling up to 8—primer, projectile, and 6 powder bags), this type of breech mechanism is not easy to adapt to automatic or semiautomatic operation.

For this reason, guns 40-mm and up, of late designs, use a breech mechanism that works on a completely different principle—the *sliding-wedge* breech mechanism. This uses a sliding element to block off the breech opening. The sliding breechblock may move either horizontally or vertically.

Figure 5B14 shows in simplified form the elements of a vertical sliding-wedge breech mechanism as it looks from the side, with the breechblock or plug in its lowered (open) position. The dotted outline represents the breechblock in its raised (closed) position. Notice that the grooves in which the plug can slide up and down are not exactly vertical; they're slanted slightly forward. It is clear that in its open position the plug is noticeably aft of its closed position. Or, in

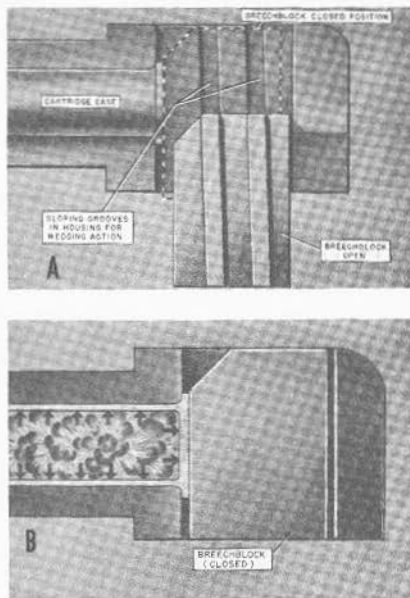

FIGURE 5B14.—Sliding-wedge breech mechanism. A. Breechblock movement. B. Sealing by expansion.

other words, in rising to the closed position, the breechblock moves forward as well as upward.

The effect of the breechblock's forward movement as it closes is to wedge the cartridge case into the gun chamber (hence the name *sliding-wedge* breech mechanism).

The method of obturation used in this type of breech mechanism depends on the cartridge case for sealing effect. There is no sealing device incorporated into the breech mechanism. Figure 5B14 shows what happens when the gun fires. As the propelling charge burns, the hot powder gases expand against the sides of the cartridge, which in turn expand against the smooth walls of the chamber and against the breechblock. Since the cartridge case tightly seals off the entire length of the chamber, the gases can escape only forward, driving the projectile. None can escape through the breech. This is sealing by *expansion*.

But after the gun fires, the chamber is not clear. The cartridge case is not designed to disappear with

the burning propelling charge, and it must be removed from the chamber before a new round can be loaded.

Therefore all guns with sliding-wedge breechblocks have one or a pair of *extractors* as part of the breech mechanism. In 40-mm, 3-inch, and 5-inch guns the extractors are mechanically operated by breechblock movement. Figure 5B15 shows several views to clarify their functioning.

When the breechblock is down (open) the extractors are pulled back. In these guns the extractors perform the dual function of locking the breechblock down and extracting the case. As a fresh round of ammunition is rammed into the chamber, the rim of the cartridge case engages the extractors, and pulls them forward. This unlocks the breechblock, which is then forced upward by a spring mechanism. The round is chambered, the breechblock moves upward, and the extractor tips move forward in a coordinated group of movements. When the breechblock is fully closed, it has forced the round fully into the chamber,

and the extractor tips have seated in recesses in the housing. (Figure 5B6 shows those recesses).

After the gun fires, the breechblock is opened by camming action. (The details of this action vary in different gun designs, and will be described in subsequent chapters.) As the block drops, the extractors retract. They haul the fired cartridge case out of the chamber and catapult it to the rear into the slide. At the extreme of their rearward movement, they lock the breechblock down until the next cartridge case again pulls them forward to unlock the breechblock.

Figure 5B15 shows the type of breech mechanism used in conventional 3-inch and 5-inch guns. In 40-mm guns the sequence of operations is similar, but the extractors are pivoted on a spindle, and lock the breechblock down with a pair of hooks. In 3-inch and 5-inch breech mechanisms the extractors are not pivoted, but rock back and forth on their forward curved surfaces, which bear against the gun housing. The movement of each extractor is controlled by two lugs;

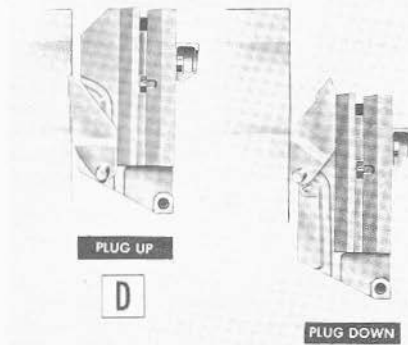
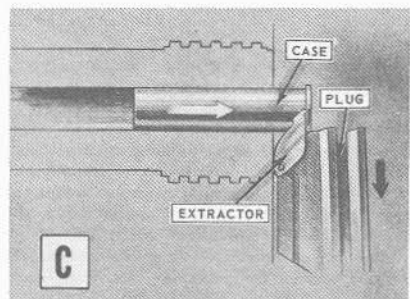
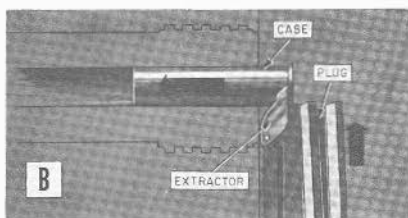
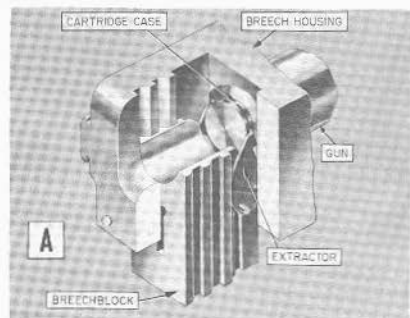

FIGURE 5B15.—Sliding-wedge breech mechanism. Extractor action. A. How the extractors grip the cartridge case. B. Ramming. C. Extraction. D. Extractor positions, plug up or down.

the inner lug engages a camming groove in the breechblock, and the outer one oscillates in a small curved groove in the housing. It is also noteworthy that in 3"/50 guns equipped with power loaders the breechblock-locking function of the extractors merely supplements the normal functioning of another locking mechanism (described in another chapter). But, regardless of the method of locking, the extractors unlock the breechblock when they are moved forward by the cartridge case being loaded.

In contrast to the sliding-wedge breech mechanisms described above, which are operated through mechanical camming and spring action when the gun housing moves backward and forward in recoil and countercoil, the breech-mechanism in 6-inch and 8-inch case guns are operated hydraulically.

The descriptions above do not apply to the very newest designs of 3-inch and 5-inch gun mechanisms with sliding-wedge type breech mechanisms. See volume 3.

**Bolt-type breech mechanisms.** The sliding-wedge and interrupted-screw types of breech mechanisms are not used in guns 20-mm and smaller. These use variants of the bolt principle. The bolt is a breechblock which moves in line with the bore axis—forward to close the breech, and to the rear to open it.

In so-called *bolt-action* weapons like the old M1903 rifle (the famous "Springfield" of World War I) the bolt is operated by hand.

In *gas-operated* weapons like the Browning automatic rifle M1918A2 (the "BAR") or the M1 rifle ("Garand") the bolt is cammed to the rear by a piston actuated by a small amount of propellant gas diverted from the barrel while the bullet is moving through the bore. Spring action forces the bolt forward to ram the next round home.

In *recoil-operated* weapons like the Browning machine guns, a complex of mechanical parts is forced to the rear to varying distances by recoil, and is then driven forward by springs to reload and fire the next round.

In *blowback-operated* weapons like the 20-mm AA gun and the Thompson or M3 submachine guns ("Tommy" guns) the bolt is pushed back, when the gun is fired, by gas pressure in the chamber, and a spring mechanism afterward forces it forward to ram the next round home.

Aircraft machine gun designs use all three of these actuating forces (gas, recoil, and blowback).

### 5B5. Percussion and electrical firing systems

An earlier chapter, on ammunition, describes the types of primers that are used in gun ammunition to initiate the propelling charge. With regard to func-

tioning, it distinguished between percussion, electric, and combination primers. It also described a special type of primer used in bag ammunition. (The other types are all associated with case ammunition.)

**Firing mechanism for case guns.** The commonest ammunition, and the commonest guns, are of the case type, and it is appropriate to look at these first. Figure 5B16 shows the principal common element of a percussion or combination firing system. Of course, not all the elements of a percussion or combination firing system are common to all gun designs. Since this chapter is concerned primarily with common elements, other important parts that are not common are omitted.

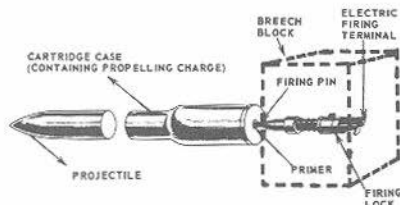

FIGURE 5B16.—Firing mechanism for sliding-wedge breech mechanism.

The important common element is the *firing mechanism*, sometimes called the *firing lock*. This part is secured in the breechblock, but is not considered part of the breechblock, and is very easily removed for cleaning. The illustration shows a combination electric-percussion firing mechanism typical of case guns 3-inch and larger.

Mechanical linkage in the breechblock operates the firing mechanism in the following ways:

1. It retracts the firing pin or striker when the breechblock is not fully closed.
2. It cocks and releases the firing pin or striker to fire the cartridge case by percussion. The part in the breech mechanism that does this is called the *sear*. (Not illustrated in figure 5B16.) In different gun designs this function is accomplished in different ways:
  - a. In the conventional 5-inch gun, for example, the firing pin or striker moves into contact with the primer in the cartridge case as soon as the breech closes fully, and remains in contact until the breechblock begins to drop. In percussion fire, a massive spring-loaded part in the firing mechanism is released by the sear in the breechblock to strike a bushing, through which the impact is delivered to the firing pin and thus to the primer.
  - b. In 3"/50 guns, the firing pin contacts the primer as soon as the breech is closed, and remains in contact

unless the percussion firing linkage is actuated. When this happens, the sear (which looks and works differently from its namesake in the 5-inch gun) retracts the spring-loaded firing pin and releases it to strike the primer.

c. In 40-mm guns the firing pin automatically strikes the primer as soon as the breech is fully closed. Firing is controlled by regulating rammer action, as described in a later chapter. The 40-mm firing mechanism is a percussion-only device.

d. In 6-inch case guns the firing mechanism closely resembles the conventional 5-inch firing mechanism briefly discussed above. In 8-inch case guns, however, the firing mechanism is stripped to the essentials needed for electric firing only. It is not a combination device. The firing pin retracts when the breech is open, and maintains contact with the primer at all times when the breech is closed. When it must be fired by percussion in emergency, a special percussion attachment must be rigged for the purpose, and a special type of cartridge case equipment with percussion primer must be substituted for the normal service cartridge, which has an electric primer.

In electric firing (for which all the mechanisms mentioned above are adapted, except the 40-mm and some older 3-inch hand-loaded mounts), all that is necessary is for the firing pin or striker to maintain good electrical contact with the case primer. When the firing circuit is closed, current passes through the cable and the firing pin through the primer's contact and filament, then by way of the cartridge case and gun to ground. The breech mechanism device which retracts the firing pin automatically prevents firing both by percussion and electrically when the breech is not fully closed.

**Percussion firing linkage (for case guns).** Mounts (40-mm and larger) in which percussion firing is considered an alternate rather than an emergency method of fire, conventionally have foot pedals at the pointer's station for control of percussion fire.

In 40-mm mounts, depressing the pedal part way causes an electrically driven firing linkage to release the rammer and initiate firing. If the electrically driven linkage is not functioning, depressing the pedal all the way initiates firing mechanically. In either case, the actual firing in the gun is done by percussion.

In 3-inch mounts of the older hand-loaded type, "electric" firing is an alternate method, but here, too, so-called "electric" firing is done by percussion; the percussion firing mechanism is actuated by a solenoid. "Percussion" firing is done by depressing the foot pedal; this operates the firing linkage directly.

In newer 3"/50 mounts with automatic loading equipment, percussion firing is an emergency expedi-

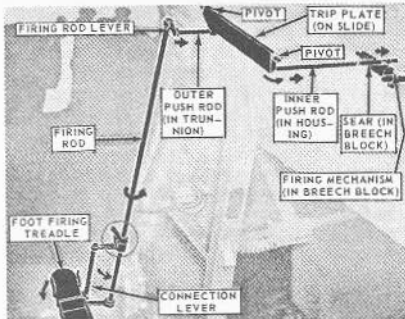

FIGURE 5B17.—5"/38 percussion firing linkage. (Simplified schematic.)

ent, and must be done by operating a control on the slide.

Figure 5B17 shows in simplified form the firing linkage for a conventional 5"/38 mount. Any percussion firing linkage from a foot pedal to the slide or breechblock uses similar mechanical elements. The little arrows show how each part of the linkage moves when the pointer steps on the treadle. The treadle tilts down, swinging the rectangular connection lever assembly aft, and so rotating the firing rod. A firing rod lever at the top of the firing rod pushes the outer push rod, which runs inboard through the inner surface of the slide. The trip plate transmits the push to the inner push rod in the housing. If the breechblock is fully closed, the inner push rod accomplishes the entire purpose of this linkage, which is to push the sear to the right. (It will be recalled that the sear releases the cocked firing mechanism.)

Note two important safety features of this linkage:

1. The trip plate can push the inner push rod only when the gun is completely in battery.
2. The inner push rod can push the sear only when the breechblock is fully closed.

In 6-inch case-type turret guns percussion firing is an alternate method, and the general operation resembles that in conventional 5-inch mounts.

In 8-inch case-type turret guns percussion firing is an emergency method. As an earlier paragraph in this article has pointed out, it requires attachment of a special percussion firing accessory and use of a special cartridge.

**Bag-type firing lock.** In bag guns the primer is in a small cylindrical case loaded separately from the remainder of the round into a primer chamber. When the gun fires, the spit of flame from the primer passes

through the primer vent in the mushroom stem of the De-Bange mechanism and ignites the ignition charge on the after end of the rearmost powder bag. This general arrangement is illustrated in figure 5B13.

The primer chamber is in the mushroom stem, and the firing operation is carried out with a *firing lock* which by means of an interrupted-screw joint fits onto the after end of the mushroom stem. The firing lock in general performs the same function as the firing mechanism in a sliding-wedge breechblock. All bag guns now in active use in the Fleet use the same firing lock, the Mark 14. (See figure 5B18.) It is described in further detail in the chapter on turrets. It has a little sliding-wedge type breech mechanism, which is mechanically linked to the gun's breech plug so that it normally closes and opens with the plug. It cannot fire the primer unless the plug is closed and locked. However, it can be opened while the plug is locked so that a defective or misfired primer can be replaced.

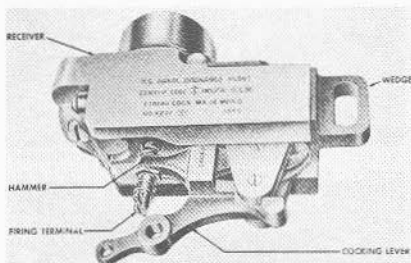

FIGURE 5B18.—Mark 14 firing lock (for bag guns).

For electric firing, the firing lock has a terminal to which a lead from the electrical firing circuit can be attached. The firing pin in the lock is kept in contact with the bag combination primer when the lock is fully closed, to permit electric firing. For percussion firing a lanyard is connected to the cocking lever on the lock; pulling steadily back on the lanyard first cocks and then releases a hammer which strikes the firing pin.

**Electric firing systems.** So far, the discussion here of electrical firing has dealt with electric or combination primers, and with the firing mechanism proper—which has as electrical elements only an insulated firing pin and a quick-disconnect terminal to which a firing lead or cable is attached. But this is only the final part of the electrical firing system.

Figure 5B19 shows schematically the elements that will be found in a typical electrical firing system for a

mount or turret. The diagram does not show scalar distances or the physical locations or appearance of the elements.

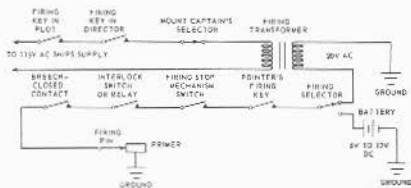

FIGURE 5B19.—Representative electrical firing circuit.

Firing under normal service conditions is performed using the ship's 115-V ac supply as a current source. Trace the circuit beginning with this source. There are switches (not shown on the schematic) in fire-control plot which determine where control of automatic fire will be placed, and at least one *firing key* on the stable element or stable vertical in plot. (The key is a spring-loaded normally open switch which may be mechanically latched in closed position.) There is a firing key in the director, and, in some mounts (like the 3"/50 with automatic loader), a selector at the mount captain's station for cutting one or both guns of a twin mount in or out of the circuit. All these are in the 115-V line to the primary of the *firing transformer* located at the mount.

The firing transformer's secondary feeds 20-V ac to a *firing selector* switch (sometimes called a *firing snap switch*). This switch, generally at the pointer's or mount captain's station (depending on the mount concerned), permits selection of a-c from the transformer or d-c from a local battery. In many mounts, the a-c position is labeled *MOTOR GENERATOR* and the d-c position is labeled *BATTERY*. The normal position, which is used if firing is to be controlled remotely by plot or by the director, selects the transformer. The battery supplies firing current in emergency, and can also supply emergency current for lamps illuminating the sight setter's scales and the sight telescope reticles. (The lamps normally get their current from an illumination transformer, not shown in figure 5B19.)

After the firing selector switch come a number of switches or contacts on the mount. The pointer's firing key is generally on one of the elevating handwheels, and is connected to the circuit by a flexible cable. The firing stop mechanism switch is part of the firing stop mechanism (to be described later). It opens the firing circuit when the gun is pointed where it will endanger part of the ship's structure. Some mounts have no interlock switch or relay, but such interlocks are a common feature of mounts with automatic loading equip-

ment or hydraulically operated breech mechanisms. The one shown in the schematic may represent up to six or more, each of which registers that a certain mechanism or part is in a position that is safe for firing. Such electrical interlocks are not limited to automatic mechanisms; even bag guns have such devices to register, for example, that ammunition handling and loading gear is in safe position for firing. The breech-closed contact is a common variety of interlock. In addition (and not shown in the schematic) are the safety devices in breech mechanisms, firing locks, and firing mechanisms, which prevent contact between primer and firing pin when the breech is not fully closed or the gun is not fully in battery.

The last part of the circuit is the firing pin's contact to the electric primer. The circuit is completed through the filament in the primer, the cartridge case, and ground return to the firing transformer or battery.

Note the emphasis on safety in this circuitry. All the switches and keys are in *series*. Any link in the circuit can break the entire circuit if conditions are unsafe at that point. Yet the mount is capable of firing under local control if the remote system has failed.

**Firing stop mechanism.** At any greater range than point-blank (a range so small that the gun need not be elevated above the line of sight to the target) a gun when correctly laid is aligned with a point other than the target. The greater the range, the greater the deviation. This makes it possible, particularly in enclosed mounts, for a pointer or trainer, looking through a telescope, to see no obstacle in the line of sight, while the gun's bore may be in line with some part of the ship's structure, so that firing the gun will damage the ship.

For this reason measures are taken either to prevent the gun bore from being brought into alignment with the ship's structure, or to prevent it from firing under these conditions. The former method is used on some 20-mm AA mounts, where a large circular cam surrounding the stand prevents depression of the gun barrel below safe limits. And on some carriers there is provision for preventing 5-inch mount power drives from positioning the gun so that its bore axis will be aligned with the ship's structure. But by far the commonest device for preventing this kind of accident is the *firing stop mechanism*, which disables the firing system when the gun is aimed on a bearing or elevation that endangers the ship on which it is mounted.

Figure 5B20 shows the fundamental mechanism used in all mounts larger than 20-mm. It is essentially a disc-type cam, in which the inputs are gun train (which rotates the cam) and gun elevation (which moves the cam follower approximately radially across the cam). A spur gear driven by the

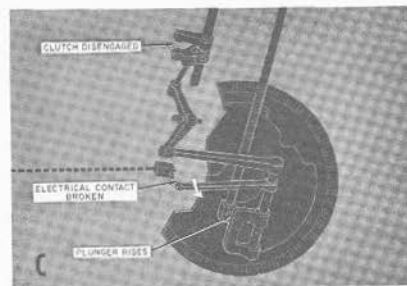
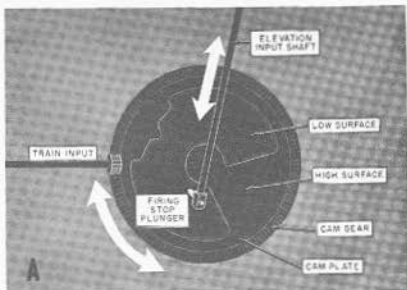

FIGURE 5B20.—Principle of firing stop mechanism. A. Mechanical inputs. B. Cam plate. C. How fire is interrupted.

mount training gear engages the radial gear teeth around the circumference of the cam plate or disc. The elevation input shaft moves toward the center of the cam plate when the gun elevates, and toward the edge of the cam plate when it depresses. At the end of the elevation input shaft is a spring-loaded plunger which maintains contact with the cam plate.

When the gun mount is installed, the axis of its bore is observed through all angles of train and elevation. Each position of the gun (as defined by its train and elevation) corresponds to a location of the plunger on the cam plate. The angles of elevation and train at which the gun endangers parts of the ship's structure are plotted on a special diagram that corresponds to the cam area. Then the cam plate surface is machined. The surface is cut so that safe areas are depressed, while danger areas remain the original surface of the plate.

Thus, when the gun is positioned at angles of train and elevation where it is safe to fire, the plunger rides on the depressed surface of the cam plate. As soon as the gun trains or elevates to a bearing or elevation which aligns the bore with any part of the ship's structure, the plunger rides on the uncut surface of the cam plate.

Plunger movement, as the plunger rides up to the uncut surface or down to the depressed surface of the cam, is communicated by a mechanical linkage to a *clutch* and to a *switch*. As figure 5B20 shows, the clutch is in the mechanical linkage of the percussion firing system. (The clutch is also shown (encircled) in figure 5B17.) The switch is in the electrical firing circuit. When the plunger is riding on a high (danger) cam plate area, the clutch is disengaged, interrupting percussion fire, and the switch is opened, interrupting electrical fire. When the plunger is riding on a low (safe) cam plate area, the clutch is engaged and the switch is closed, permitting fire.

Firing stop mechanism functioning is completely automatic. It requires no attention from the gun crew after installation, beyond periodic maintenance checking to see that it is functioning properly and requires no adjustment. Only if the mount location or ship's structure is changed is it necessary to revise the cam plate. In this case, the cam plate is replaced by one cut to a new pattern.

Firing stop mechanisms on turrets function only to interrupt the electrical firing circuit. (There is, obviously, no way to interrupt the percussion firing linkage, since the only connection between the firing lock and the individual firing the gun by percussion is a lanyard.) Therefore an indicator lamp for each gun shows whether or not the gun is positioned on a safe bearing and elevation.

#### 5B6. Recoil and counterrecoil systems.

Novels about life aboard naval vessels of a hundred years ago or more, frequently have at least one scene in which a naval gun mount breaks loose—either in battle, during a storm, or both—and thunders, an uncontrollable juggernaut, across the deck as the ship

rolls in heavy seas. This is something that can scarcely happen aboard a modern naval vessel; other gear may break loose, but it is hard to see how a gun mount can. Why were not the guns in the days of sailing vessels simply secured to a fixed mounting, as guns are today?

The answer is that modern guns have recoil and counterrecoil mechanisms, and ancient guns did not. A naval gun can be rigidly secured to the deck, but without some provision for its recoil it will break loose when fired.

Recoil is simply the manifestation of the third of Newton's three laws of motion—the one that says, with deceptive brevity: "To every action there must be an equal and opposite reaction." The enormous thrust that can send a ton of steel screaming at supersonic speed toward a target over 20 miles away acts not only on the projectile, but on the gun. Yet, though the recoil of a full broadside salvo on a BB will push it sideways like a piece of driftwood, the guns themselves do not break loose and roll threateningly across the deck. Why?

The answer, again, is that these guns have recoil and counterrecoil mechanisms.

The antique naval gun was fired from "battery" position—with the mount pushed as far outboard through the gun port as the bulkhead would permit. Its recoil hurled it inboard, rolling on its wheels until it brought up against its stout tackle. In this "recoil" position, well back of the gun port, the bore could be swabbed, and the powder and ball loaded for the next shot. Then the crew hauled it up to battery position, and lit off the primer to fire again.

Thus in naval guns the entire gun carriage, or what we would now call the mount, was rolled backward in recoil and forward (manually) in counterrecoil. Artillery ashore did this too; the classic example (1904) is the Russian gunners fighting up a hill at Port Arthur—firing, then chasing madly down the hill after their runaway pieces, and laboriously hauling them up the hill again (if they could get them up) for the next round.

As naval gun mounts evolved, control over recoil improved. Engravings of the interior of post-Civil War monitors (early descendants of the Union's pioneer armored and turret-equipped war vessel) show tracks on which the great guns recoiled when fired. But it wasn't until shortly before World War I that effective recoil brakes and counterrecoil mechanisms were developed. These were, for the time, triumphs of metalworking accuracy and engineering ingenuity, and were treated as military secrets, much as a new type of radar application or atomic bomb trigger mechanism is treated today.

There are a number of different types of recoil brakes and counterrecoil mechanisms that have been found efficient in land artillery and elsewhere, but the United States Navy uses in naval gun mounts but 1 general type of recoil brake (in either of 2 variants) and but 2 kinds of counterrecoil mechanism. But before considering these, note the general functions of these devices:

1. A recoil brake is primarily designed to absorb the force of recoil and "spread" it so that the sudden heavy shock is converted to a thrust exerted over an appreciable distance through which the recoiling parts of the gun are permitted to move. In the mechanical sense, work is done by the recoil force in pushing the gun and housing aft against the resistance of the recoil brake; the energy absorbed in the brake appears as heat.

a. A secondary function of all recoil brakes in naval gun mounts is to bring to a smooth stop by dashpot action the forward movement (counterrecoil) that follows recoil.

2. A counterrecoil mechanism is a device that stores some of the energy of recoil and uses it to force the recoiling parts forward into battery after the projectile has left the gun muzzle. (The energy of recoil can, of course, be traced ultimately to the combustion of the propellant.)

Recoil and counterrecoil mechanisms are designed to work together. Figure 5B21 shows in a general way where the recoil and counterrecoil systems are located in a conventional 5-inch mount.

**Recoil systems.** All present-day recoil systems for naval guns larger than 20-mm use hydraulic recoil brakes. A hydraulic recoil brake is a mechanism of the type commonly termed by engineers a "dashpot." It has a piston and a cylinder which can move with respect one to the other. There is a liquid in the

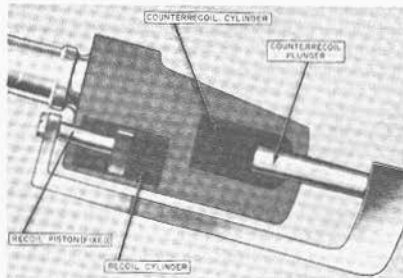

FIGURE 5B21.—Recoil and counterrecoil systems in a conventional 5-inch mount.

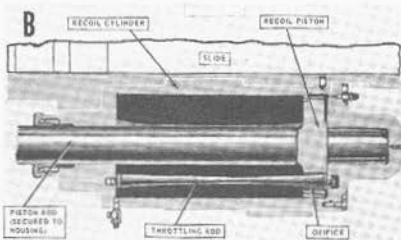
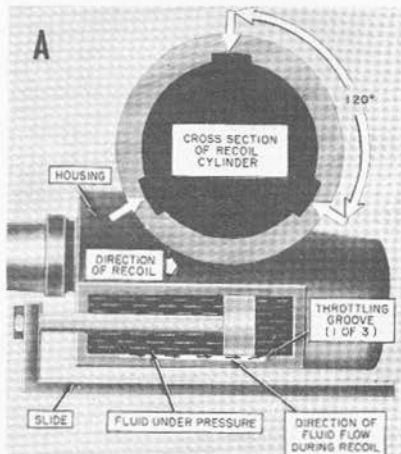

FIGURE 5B22.—Hydraulic recoil brakes. A. Throttling-groove type. B. Throttling-rod type.

cylinder which can move from one side of the piston to the other, but its rate of movement is restricted or "throttled."

The two general variants of this type of device are shown in figure 5B22. In one variant (A in the figure), the piston is solid, and each cylinder is filled with recoil fluid (usually a mixture of water with glycerin). In the wall or liner of each cylinder are cut three throttling grooves 120 degrees apart. They are shallow at the forward end of the cylinder and deepen toward the after end.

When the gun is fired, the force of recoil pushes the housing and the recoil cylinders within it to the rear, thus exerting pressure on the fluid in the forward end of the cylinder.

But the throttling grooves permit the fluid to flow around the piston at a reduced or throttled rate. The cylinder can, therefore, yield to recoil thrust and move aft, subject to the continuous braking action of the hydraulic fluid as it flows through the grooves from the forward end of the cylinder to the rear. Since the recoil fluid can flow only at a rate proportional to the size of the throttling grooves, the recoil brake resists the force of recoil over its entire stroke.

In effect the recoil brake, by distributing the force of recoil over the length of the recoil stroke, converts this force from a sudden, destructive impact to a still-powerful, but controllable, thrust exerted over a considerable distance.

Note that the grooves are TAPERED. (In the figure, in order to show this more clearly, both the taper and the size of the groove are exaggerated.) At the beginning of the stroke the grooves are comparatively deep, so that the fluid will not offer too much resistance to the initial thrust of recoil. As the housing moves aft, the grooves become shallower, until by the end of the recoil stroke the grooves are very shallow indeed. By this time the force of recoil is spent, and, by throttling the fluid flow down, the shallow grooves help to bring the housing to a smooth stop.

In the conventional 5-inch gun there are two recoil cylinders of this kind, symmetrically arranged about the long axis of the housing. Since the cylinders are bores in the housing, in this design the cylinders move in recoil while the pistons are fixed to the slide by the piston rods. A transverse bore in the housing, called the *equalizer hole*, permits enough fluid flow between cylinders to equalize the pressures built up and the resistance offered by the two cylinders to recoil movement.

In other designs, there may be but 1 recoil cylinder, or 2 cylinders may be arranged asymmetrically. Or the recoil cylinder may be in the slide, while the recoil piston rod is secured to the housing. All of these variations on this type of recoil brake can be found in United States naval gun mounts.

The other major variant in recoil brakes is in guns 6-inch and larger. This kind of recoil brake has a somewhat different method of controlling recoil fluid flow. Instead of being solid, the piston has 3 holes bored in it, spaced 120 degrees apart. Through each of the holes passes a tapered *throttling rod* secured to the ends of the recoil cylinder so that it is parallel to the piston rod. (For simplicity's sake, only one throttling rod and hole are shown in figure 5B22.) There are no throttling grooves.

As the piston moves in recoil, the fluid that it displaces can flow from one end of the cylinder to the other only through the holes. Because the throttling rod varies in diameter at different points, it blocks off a varying portion of the hole as the piston moves in its stroke. Where the rod's diameter is large, for instance, it blocks off most of the hole, leaving only a small opening for fluid flow, and the braking effect is large. Where the rod is small, on the other hand, less of the opening is blocked, and more fluid can pass, with decreased braking effect. The rods are so tapered as to provide evenly distributed resistance to recoil thrust over the length of the recoil stroke.

One advantage in the use of throttling rods is that the rods can be replaced with others of different taper if a change in the gun's recoil characteristics is desired.

All recoil systems used in United States naval guns incorporate a *counterrecoil buffer* dashpot mechanism used in bringing counterrecoiling parts to a smooth stop. This is discussed further in connection with counterrecoil systems.

*Counterrecoil systems.* There are 2 basic types of counterrecoil systems (also called *recuperator*) used in United States naval guns. Guns smaller than 5-inch use 1 or more *counterrecoil springs*. (These are sometimes termed *recoil springs* in OP's and elsewhere, but the function is the same.) Guns 5-inch and larger use pneumatic recuperators, which depend on compressed gas (generally air or nitrogen) to provide counterrecoil thrust. Since the very high-pressure gas used in such systems is sealed by use of packings under hydraulic pressure, such systems are most often called *hydropneumatic counterrecoil systems*.

The functions of any counterrecoil system are primarily to return the recoiling parts of the gun to battery after the recoil stroke, and secondarily to hold the recoiling parts in battery. Thus a counterrecoil system must not only provide thrust to return the recoiling parts to battery, but must also develop enough *continuous* thrust at all times to hold them there except while the projectile is actually being propelled through the bore. This is in contrast with recoil brakes, which develop their "reverse thrust" for braking only while the recoiling parts are actually moving in recoil, and at other times exert no forces on the gun parts.

Because it continues to develop a heavy forward thrust "following through" to the end of the counterrecoil stroke, any counterrecoil system tends to drive the recoiling parts into battery with considerable shock. For this reason, all counterrecoil systems for guns with massive recoiling parts (which include guns 40-mm and up) must have a *counterrecoil buffer* to take up this terminal shock. Counterrecoil buffers are discussed in further detail below.

*Spring counterrecoil systems.* In all naval guns

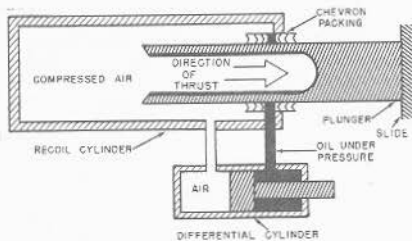

FIGURE 5B23.—Hydro-pneumatic counterrecoil system. (Simplified schematic.)

smaller than 5-inch, coil springs provide counterrecoil thrust. In late 3"/50 mounts and most 40-mm mounts, the springs surround the exterior of the barrel (water jacket in 40-mm mounts). In single Army-type 40-mm mounts and in some earlier marks of 3"/50 hand-loaded mounts the springs are concealed; in some 3-inch mounts they may be the recoil cylinder.

**Hydro-pneumatic counterrecoil systems.** Figure 5B23 shows in simplified form how a pneumatic counterrecoil system works. It requires a cylinder or bore (in the housing) charged with gas (generally nitrogen or air, never oxygen or other chemically active gas). Gas pressure in a conventional 5-inch system

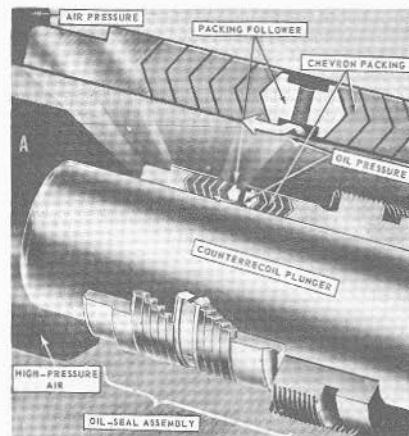

FIGURE 5B24.—Hydro-pneumatic counterrecoil system. Detail of oil-pressure type chevron packing.

(which is typical) is around 1,500 psi. A plunger fitting into the after end of the housing is forced outward (to the rear) by the gas pressure against the after end of the slide. The thrust exerted by the plunger against the slide holds the housing in battery and returns it to battery after firing.

The complication of this arrangement lies in the packing which surrounds the plunger in the housing. Ordinary packing, unsupported, will not withstand the gas pressure in the counterrecoil chamber. Therefore the packing used is a *chevron* type "inflated" by oil under pressure. (Figure 5B24.) The oil pressure in the packing is always higher than that of the gas in the cylinder. Figure 5B25 shows functionally the device that ensures this pressure relationship—the *differential cylinder*.

One end of the differential cylinder (to the left in figure 5B25) is connected to the air chamber. The other (right end in figure 5B25) is connected to the oil-charged packing, and is full of oil. The piston is free-floating, and the piston rod on the oil side goes through a packing gland to the outside, but does not connect mechanically to any other component.

The values for dimensions and pressures shown in the figure and in the discussion below are not intended to represent any specific installation, but serve only to illustrate the principle of the differential cylinder. Suppose the total area of either face of the piston is 3 square inches, but the cross-section area of the piston rod is 1 square inch. The air pressure of 1,500 psi is exerted on the full piston area of 3 square inches, and the total thrust or force developed is  $3 \times 1,500$  or 4,500 lbs.

But on the other side of the piston only 2 square inches are exposed to oil pressure, since 1 square inch is occupied by the piston rod. (For the sake of simplicity, atmospheric pressure on the outside end of the rod is neglected in this example.) The oil is therefore subjected to a thrust of 4,500 lbs. exerted on a 2-square inch area. Hence it is under a pressure of 2,250 psi, which is higher than that of the air (1,500 psi). The pressure is communicated to the packing.

It is obvious that even though the air pressure fluctuates, the pressure relationship will remain the same (in the ratio, oil to air, of 3:2), so that the packing will always be under higher pressure than the air.

The differential cylinder serves not only as a device to maintain pressure in the packing, but also as an indicator of oil level in the sealing system. When the differential cylinder is fully charged with oil, the plunger is flush with the end of the cylinder. If oil leaks out, the piston is driven farther to the oil side (to the right in figure 5B25). Gun mount maintenance personnel are supposed to inspect the cylinder daily,

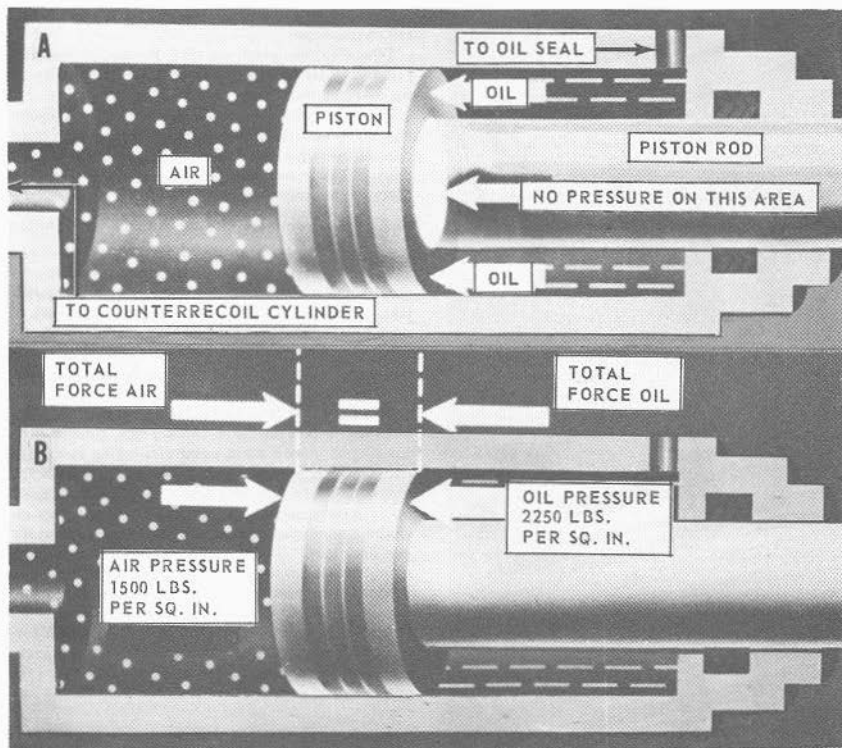

FIGURE 5B25.—Hydropneumatic counterrecoil system. Principle of differential cylinder.

and to see that oil is pumped in if the piston rod protrudes more than 2 inches.

**Counterrecoil buffers.** It was brought out earlier that any counterrecoil system must develop enough thrust to hold the recoiling parts in battery, and that in guns whose recoiling parts have appreciable mass the shock at the end of the counterrecoil stroke can be considerable. Counterrecoil buffers must consequently be incorporated into the gun mount to reduce this shock. These are not physically part of the counterrecoil system components described above; in present designs, they are located in the forward end of the recoil cylinders.

Counterrecoil buffers are dashpot devices which use oil forced through small orifices to reduce the velocity

of counterrecoiling parts at the end of the counterrecoil stroke. A typical design (similar to that in 5-inch guns) is shown in figure 5B26 (left), in three stages of operation. As counterrecoil movement begins, the housing and recoil cylinder move forward over the recoil piston. The buffer plunger, which closes off the after end of the recoil cylinder, is aligned to enter a hole in the recoil piston and piston rod. As the plunger enters the hole in the piston, the fluid caught therein is trapped, and can escape only through small passages in the plunger. At the end of the counterrecoil stroke (full battery position), the plunger is entirely nested within the recoil piston and piston rod.

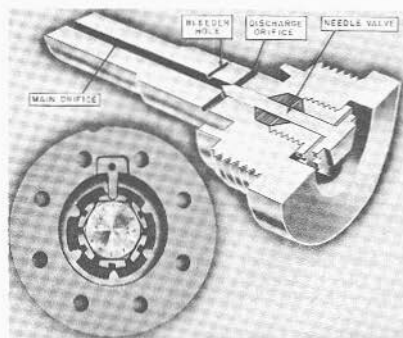

FIGURE 5B26.—Counterrecoil buffer functioning.

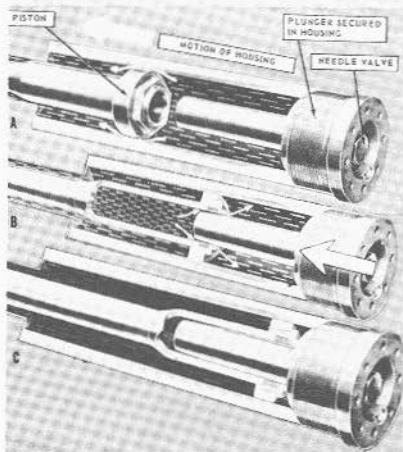

FIGURE 5B26.—(Continued.) Needle valve control.

As is evident from figure 5B26, the flow of fluid through the counterrecoil buffer plunger is controlled by a *needle valve*. This valve can be set by moving a calibrated nut in the recoil cylinder head. (Figure 5B26, right.) By controlling the flow of the liquid through the discharge orifices or holes, the needle valve controls the speed of counterrecoil. The numbering on the calibrated valve nut makes it possible to set both buffers for equal, balanced functioning. For

the proper procedure in setting these valves, see the OP on the mount.

Where (as on 5-inch mounts) there are two recoil cylinders, each with a buffer, the valves must be set for balanced functioning.

Note that the counterrecoil buffer regulates only the end of counterrecoil movement. This provides some control over the rate of fire of automatically loaded guns, but does not regulate the recoil stroke or most of the counterrecoil stroke.

### 5B7. Power rammers and mechanical ammunition feed

The effectiveness of a gun per round fired is concerned with such factors as range, efficiency of propellant, accuracy of fire, weight and initial velocity of projectile, explosive filler of the projectile, and the like. But the effectiveness of a gun as a weapon depends on the number of rounds per minute it can put into the target.

It is here that mechanical loading and feeding devices are important. For convenience, these can be considered in two main categories. One is that of *hoists*, which are used to lift ammunition from the magazine to the gun deck level. These will be taken up in a subsequent article. The other category includes ammunition feeding and loading devices at the gun deck level. These include power rammers, slide-mounted ammunition loading gear, and equipment used to transfer ammunition from the hoist to the gun slide.

In 5-inch mounts through Mark 39, in 6-inch turrets of *Cleveland* class cruisers and in bag gun turrets, separate *power rammers* are used for moving into the gun chamber ammunition which has been loaded into the slide.

Figure 5B27 shows a slide-mounted rammer on a 5-inch mount. Here a piston in a long-hydraulic cylinder operates a reciprocating rubber-faced *rammer*

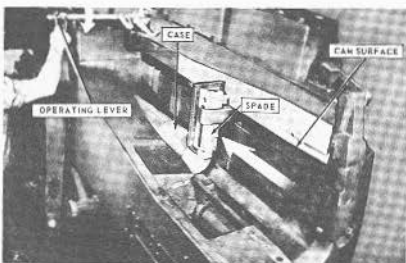

FIGURE 5B27.—Slide-mounted power rammer in 5-inch mount. Initiating ram stroke.

*spade or shell guard.* The rammer is controlled by a rammer man. When a projectile and powder case have been deposited in the gun slide loading tray by the loaders, the rammerman depresses a lever on the rammer control rod. The rammer hydraulic cylinder, fed by a motor-driven pump on the slide, drives the piston, piston rod, and rammer spade forward, pushing the round into the chamber. When the cartridge case is in the chamber, it automatically releases the breech mechanism (as has been described earlier in this chapter) and the breechblock rises. When the gun fires, the rammer spade rides backward with the housing; this automatically (through mechanical linkage to a control valve) initiates the rammer retract stroke. The rearward-moving spade rides a camming groove in the slide which raises it well above the loading tray, so that it offers no obstruction to the extraction of the fired cartridge case. The spade is dropped to ram position manually. Except for this operation and for initiating the ram stroke, all rammer operations on this type of mount are automatic.

This rammer arrangement is used in all 5"/38 mounts and in the 5"/54 Mark 39. The only notable difference among them is that in enclosed mounts the rammer hydraulic cylinder is shortened and a rack-and-pinion arrangement is used to make the stroke of the rammer space the proper length for ramming.

The rammer in the 6-inch *Cleveland* class mount is of a similar type.

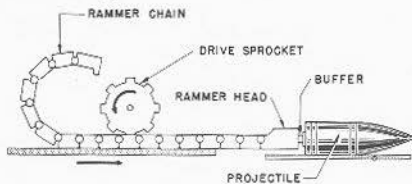

FIGURE 5B28.—Principle of chain-type rammer.

Bag-type turret guns have long chambers, to accommodate (in 16-inch guns, for instance) up to six powder bags plus the projectile. This means that the rammer stroke must be very long. The length of a single hydraulic cylinder for such a rammer would be prohibitive. Such turrets are therefore equipped with *chain-type* rammers.

Although the details of operation differ from one type of bag turret to another, all of them work on the principle illustrated in figure 5B28. A rotary hydraulic motor drives a sprocket which engages the links in a *rammer chain*. This is somewhat like an exaggerated bicycle chain, except that the straight chain will bend in only one direction (in the figure, upward

only), and is stiff in the other. As the figure shows, in the type illustrated the links will remain straight without continuous support when extended horizontally.

At the end of the chain is a buffer to protect the ammunition component being rammed. In bag-gun turret installations, the rammer operation is always under manual control, generally by regulating pump output to the hydraulic motor that drives the chain. The ramming operation requires two ramming strokes. In the first, the projectile is rammed home in a full maximum-thrust stroke, to ensure that the rotating band engages the rifling. Then the rammer is retracted, and the powder bags are rammed much less forcibly in a second stroke. After the second retraction the breech can be closed. Two strokes are necessary because the maximum-thrust stroke needed for the projectile would damage the powder bags. (The 5-inch rammer discussed previously is used with propelling charges housed in sturdy cartridge cases, so only one ram stroke is needed.)

Newer designs of 3-inch mounts, 6-inch turrets, and 8-inch turrets all include a great deal of almost entirely automatic ammunition-handling gear. In the turrets, this equipment transfers the ammunition from the hoist to the slide (except that in the 6-inch design the projectiles must be manhandled through this stage), rams it into the chamber, and then disposes of the empty cartridge cases after firing. In the 3-inch gun, as in 20-mm and 40-mm machine guns, the ammunition is loaded manually into a loading device on the slide of the gun, and the ammunition is handled automatically from that point.

But notice the distinction between 3-inch and larger ammunition-handling machinery, and that in true machine guns like the 20-mm and the 40-mm. In the latter, the ammunition-handling gear is operated by energy developed ultimately in the burning of the propelling charge. In the former, the ammunition-handling gear, though some operations are controlled by recoil and counterrecoil movements, is powered by an external source. In the 3-inch mount, the loader mounted on the slide of each gun is powered by an electric motor. In the turrets, the automatic loading equipment is driven by electrohydraulic gear.

Because each type of mount or turret has its own design of ammunition-handling equipment, these units are described in further detail later in this textbook, each in connection with the mount of which it forms a part.

### 5B8. Power-driven ammunition hoists

One of the earliest operations to be mechanized in connection with gun operations on naval war vessels was that of ammunition transportation. In the clas-

sic warship of Nelson's day, black-powder propelling charges were stowed in magazines below the waterline, and were brought up to the gun decks by agile runners. Even with the slow rate of fire characteristic of contemporary cannon, there must have been delays and traffic jams in ships of the line of 80 guns or more, as runners scurried below to fetch their charges, then climbed up to the gun deck, the precious (and dangerous) charges guarded against sparks by being wrapped in the sailors' shirts.

One of the forerunners of modern shipboard ammunition supply systems was the mechanical hoist arrangement on the *Monitor*, which pioneered in naval warfare in so many other ways.

*Ammunition supply systems.* Figure 5B29 shows in cutaway form the ammunition supply arrangements for a modern 5-inch twin mount. At the lowest level is the *magazine*, in which are stacked the propelling charges. The magazine partly surrounds the *lower handling room*, which is separated by a flameproof

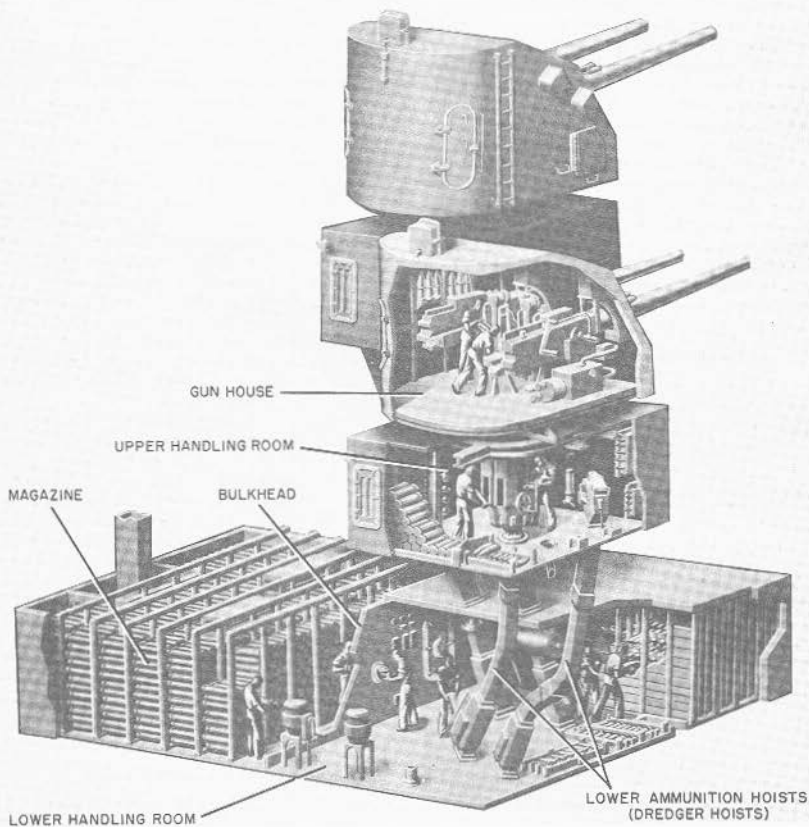

FIGURE 5B29.—Ammunition supply system for 5"/38 twin mount.

bulkhead from the magazine. Powder cases, which are stored in the magazine, are passed by hand through scuttles in the magazine bulkhead to the lower handling room. (Projectiles are normally stored in the lower handling room itself, in racks in the upper handling room, and on the gun-house bulkheads.)

The powder cases and projectiles are then loaded into the 2 *dredger hoists* (1 for each of the 2 guns in the mount) which haul them up to the *upper handling room*. Each dredger hoist handles both projectiles and powder cases.

On the upper handling room deck are located the upper ends of the 2 dredger hoists, and around the central column in the room are mounted the 2 sets of *projectile hoists* and *powder hoists*, 1 projectile hoist and 1 powder hoist for each gun. The handling room crew removes the projectiles and powder cases from the dredger hoists, loads the projectiles into the projectile hoists, and loads the powder cases into the powder hoists. In 5-inch hoists powder cases are loaded into the hoist base up to protect the impact-sensitive combination primer from being jarred by jolts on the base of the case. Five-inch projectiles also go into their hoist base up to protect their noses will rest in the hoist fuze-setting mechanism.

Most of the propelling charges are stored in the magazine, and most of the projectiles are stored in the lower handling room. To begin ammunition service without delay, a number of complete rounds are maintained in ready racks in the upper handling room. For long periods of sustained fire, however, the entire ammunition supply system must be in action.

With smaller mounts like the 3"/50, 40-mm, and 20-mm, hoists are relatively unimportant. Generally their ammunition is stowed in ready-service lockers nearby, and is hand carried to the mounts, though hoists may be used (depending on the installation) to replenish supplies. In turrets, the entire ammunition supply system, except the magazines themselves, is inside the turret and rotates with it.

*Types of hoists.* All gun ammunition hoists on modern United States naval vessels can be classified into one of the following categories:

1. Endless-chain.
  - a. Hoist-or-lower multistage.
  - b. Hoist-only single-stage.
2. Elevator.
3. Pawl.
4. Open-tube.

The most widely used is the first class (in its two subtypes). The other 3 are used exclusively in turrets (though at least 1 rocket mount design employs No. 3). No. 4 is an auxiliary.

*Endless-chain hoist-or-lower multistage hoist.* This is the commonest type of hoist, and includes all dredger hoists, conventional 5-inch powder hoists, and a number of others used in turrets and elsewhere. Fundamentally, it consists of an articulated endless chain with supports or *flights* secured to it at regular intervals (fig. 5B30). Powder cases or projectiles are loaded by pushing them into the hoist in the path of the flights; when the hoist starts, the chain is driven upward until the next vacant flight is in loading position. When the next unit is loaded, the hoist goes up one more flight, and so on. Except in certain turrets, the hoist starts automatically when the ammunition detail is loaded, actuating a switch or hydraulic valve. Endless-chain hoists are driven by rotary hydraulic motors whose functioning is controlled by valves.

Endless-chain hoists generally can be operated in reverse to lower ammunition units, as is required in taking ammunition aboard. In either mode of operation, the hoist moves one flight at a time, inter-

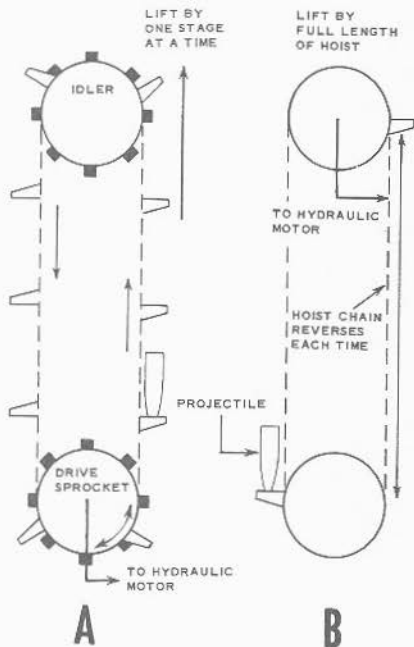

FIGURE 5B30.—Principles of endless-chain hoists. A. Hoist-or-lower multistage. B. Hoist-only single-stage.

mittently in the same direction. Only one side of the chain is used.

**Endless-chain hoist-only single-stage hoists.** Like the preceding type, this hoist is an endless chain driven by a rotary hydraulic motor. It is used in 5"/38 and 5"/54 (Mark 39 only) mounts, and incorporates a fuze setter (described in a later chapter). Both sides of the chain are used (fig. 5B30). There are 2 flights, arranged so that when one is at the top of the hoist on one side, the other is at the bottom of the hoist on the other. The chain runs first in one direction, then the other, and the flights always move from all the way at the top to all the way at the bottom (or vice versa). The arrangement is similar to that of the old-time well with 2 old oaken buckets, one of which descended while the other went up.

The projectile is loaded into one side, and automatically the hoist starts if the top is empty. As the loaded flight ascends, the empty comes down. The cycle reverses for the next projectile.

This type of hoist can be used for hoisting only. It is not safe to attempt to lower projectiles in it.

**Elevator-type hoists.** This kind of hoist is a single-stage system with a car which is moved up or down a hoistway. The car is secured to a hydraulically operated system of cables—a *hoisting cable* and a *downhaul cable*. Both are always in tension, and provide positive control of the car position. Unlike conventional elevators ashore, the car has no counterweight.

The principal application for hoists of this type is to haul powder in bag-type turrets. Although protected by interlocks, such hoists are generally manually controlled. All loading and unloading points in such installations are protected by interlocked flametight doors.

In 8-inch bag-type turrets (*Baltimore class*), there are two sets of elevators. One set hoists the powder bags to an intermediate flametight compartment where they are manually transferred to a second set, in which the bags are hoisted the rest of the way to the gun deck level. In the transfer compartment interlocks prevent the protective flametight doors of the lower hoist upper end from being open at the same time as the doors of the upper hoist lower end. This arrangement avoids the possibility of having a straight path open to flame from the gun deck level to the magazine level.

In 16-inch turrets a single elevator-type powder hoist serves each gun, but operating procedures provide for opening the hoist upper doors only when conditions in the gun compartment are safe.

**Pawl-type hoists.** In this type of hoist the hoist tube is equipped with a set of spring-loaded pawls a

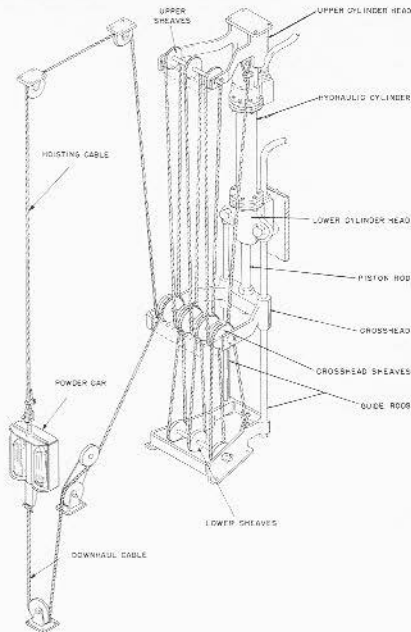

FIGURE 5B31.—Schematic of car hoisting machine (lower powder hoist) in 8-inch *Baltimore class* turret.

given distance (one "stage") apart. The pawls protrude into the hoistway. Running the length of the hoistway is a jointed *rod*, or *rack*, similarly equipped with spring-loaded pawls one stage apart. The rod can be hoisted one stage by a hydraulic cylinder, then lowered back to starting position. This type of hoist is used for hoisting projectiles in 8-inch and 16-inch bag turrets, and in one rocket mount for hoisting rockets.

The operating cycle is as follows:

1. A projectile is loaded at the lowest level. It is supported by the hoistway (stationary) pawl.
2. The hoist cylinder pushes the hoist rod upward one stage. At the beginning of the upward stroke, the lowest rod pawl engages the projectile base, and lifts it. The end of the upward stroke is just above the next hoistway (stationary) pawl.
3. Next, the rod is lowered back to starting position. The projectile is deposited on the hoistway pawl just below it. Another projectile can now be loaded into the first (lowest) stage.

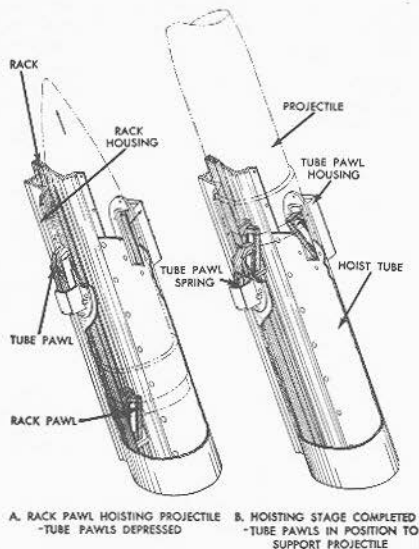

FIGURE 5B32.—Principle of pawl-type hoist.

4. At the next upward stroke of the rod, the next higher rod pawl engages the projectile, and raises it another stage, where it can be supported by the next higher hoistway pawl.

The process repeats until the projectile is at the top of the hoist. It must be removed (by loading into the gun) before another cycle can begin.

**Open-tube hoists.** This kind of hoist is a simple open tube connecting one level of a bag-type turret with the next higher or lower level. Secured to the overhead above the tube is a small motor-driven hoist equipped with block and tackle, or with internal gearing and hoist chain. Normally the tube is closed by a flametight cap. The arrangement is used for hoisting or lowering projectiles when taking ammunition aboard or transferring it from one level to another. It is not designed for use as part of the normal path of ammunition from stowage point to the gun deck.

**Ammunition hoist safety features.** Noteworthy safety features of ammunition hoists include:

1. Automatic hoists have doors or gates which will permit them to start up only after the ammunition item has been completely inserted into the hoist and the loader's hands have been withdrawn.

2. Automatic hoists will not start automatically when loaded if the top level discharge point is occupied with ammunition.

3. All hoists in which powder bags are handled are equipped with flametight doors and interlocks to prevent an open flame path between lower handling room and gun deck.

4. Most power-operated ammunition hoists are equipped for manual operation in event of power failure.

5. Ammunition hoists are equipped with hydraulically actuated brakes or hydraulic locking to prevent loaded flights or cars from falling or drifting down the hoistway.

6. Most hoists are equipped with indicators to show whether there is an ammunition item at the receiving end of the hoist.

### 5B9. Miscellaneous safety features

Some of the safety features of modern gun mounts and turrets have been taken up in connection with the other mechanisms or systems discussed above. But there are several additional noteworthy ones that should be taken up briefly. These are discussed in detail and illustrated in later chapters of this text, where appropriate.

**Salvo latch.** This is a device that locks the breech closed. It can be opened only by deliberate effort. The function of the salvo latch is to prevent accidental manual opening of the breech in the event of misfire.

Salvo latches are part of the breech mechanism of all guns larger than 40-mm, except for the very newest designs of automatically loaded guns like the 8-inch case gun used in *Salem* class turrets. It is also omitted from guns smaller than 3"/50.

The salvo latch is a positive lock which is, in present designs, cammed to open automatically during recoil of the gun. It will not open automatically if the gun does not recoil.

**Safety link.** The safety link is a metal strip that couples the breech yoke (in bag guns) or housing (in case guns) to the slide. It is intended to hold the gun in battery in the event of failure of the counterrecoil mechanism, or if the counterrecoil mechanism is disabled. It is used in guns equipped with hydropneumatic counterrecoil systems.

If the gun is fired with the safety link engaged, the link will part. However, it is part of the normal gun operating procedure to disconnect and stow the link before firing. The link *must* be replaced when the mount is secured.

**Gas ejection.** When a shot is fired from a gun, the bore is filled with residual powder gas. The gas is unsafe for humans to breathe, and is likely to be either flammable or actually burning; it is sometimes capable

of spontaneous combustion when mixed with air. The function of the gas ejector, which is a part of every enclosed mount 5-inch and larger, is to force this residual gas out of the bore by a blast of air from the ship's air system.

In case guns the gas ejector is designed to open and shut off automatically during normal operation, though it can be operated manually. In bag guns the gas ejector goes on automatically when the breech plug opens, but must be shut off manually by the gun captain.

When a gas ejector fails, the gun can continue firing, but caution is necessary to ensure safety. The rate of fire may have to be reduced. In bag guns, powder bags for the next round must not be exposed until fumes and embers have been cleared away. Inspection for smoldering embers is required in any event in bag guns, but it is especially important in case of gas ejector failure.

### 5B10. Sighting and fire-control equipment

With the increase in ranges of modern guns the problem of aiming the gun has become more complex. Sighting is considerably more complicated than merely pointing the gun at the target and firing. A projectile, when fired, travels in a curved path, not a straight line. This curved path is called the *trajectory*.

Many factors affect the trajectory of the projectile. The major factor is the force of gravity, which causes the projectile to start falling as soon as it leaves the support the barrel provides. To fire at long range, the bore axis of the gun must therefore be elevated. Another force affecting the trajectory is the wind, which tends to blow the projectile off its course. Then there is the problem of the moving target. While target motion does not affect the trajectory, the gunner must lead the target the proper amount to hit.

These factors and others complicate the problem of aiming a gun. The solution of this problem is in the field of *fire control*. The fire control system, in solving the gunnery problem, computes the angle by which the bore axis of the gun should be offset from the straight line between the gun and the target. This straight line is called the *line of sight* (LOS). It is the starting point in aiming the gun. With the line of sight on target, and the bore axis offset the correct amount, the gun is aimed for a hit.

The offset is divided into 2 components, 1 vertical, called *sight angle*, and 1 horizontal, called *sight deflection*. Sight angle and sight deflection are the angular values of the offsets which the fire control system computes and transmits to the gun for use in aiming (fig. 5B33).

The sights at the gun provide for establishing the

line of sight and for introducing sight angle and sight deflection so that the gun's bore axis will be properly offset. In gun mounts 3-inch and larger, sights generally consist of telescopes which move in train and elevation with the gun and also can be moved vertically and horizontally with respect to the gun bore axis to introduce sight angle and sight deflection. For accuracy at long range, telescopes give an enlarged view of the target.

One telescope is provided for the gun pointer and another for the trainer. Each telescope has a reticle with a vertical and a horizontal crosshair to establish accurately the line of sight to the target. The pointer elevates or depresses the gun to get the horizontal crosshair on target, and the trainer trains the mount to get the vertical crosshair on target.

Offsetting the sight telescopes with respect to the bore axis is the duty of a third member of the mount crew, the *sight setter*. The computed value of sight angle and sight deflection to be used is sent by telephone or indicated on dials to the sight setter. He has two handcranks which he uses to move the telescopes, one to shift them vertically by the amount of sight angle, the other to move them horizontally by the amount of sight deflection. The sight-setting mechanism has scales which enable the sight setter to crank in the precise values.

On most mounts, there are two scales the sight setter can use to introduce sight angle (the vertical offset). One is graduated in minutes of arc, to display the actual value of the angle. The other is graduated in yards of range. This is called the *sight bar range* scale. It is designed for use against surface targets only. This range scale is used when the fire control system transmits the range to target (plus or minus corrections for wind, target motion, etc.), in linear units—yards. Most modern fire control systems transmit sight angle in minutes of arc. But some auxiliary systems still use linear values (yards on the sight bar range scale). Whichever scale is used, the sight setter turns the same handcrank to set the desired value.

To introduce the correct amount of horizontal offset, the sight setter sets the value of sight deflection on the sight deflection scale, graduated in *mils*. (A mil is the angle subtended by an arc of length equal to one-thousandth of the arc's radius—equivalent to 3.44 minutes.) This value is computed by the fire control system and sent to the gun. There it is set on the sight deflection scale by the sight setter with the deflection handcrank.

In aiming a gun, the pointer, trainer, and sight setter work as a three-man team. The pointer sights through his telescope and keeps the horizontal crosshair on the target. The trainer sights through his telescope, keeping the vertical crosshair on the target. This estab-

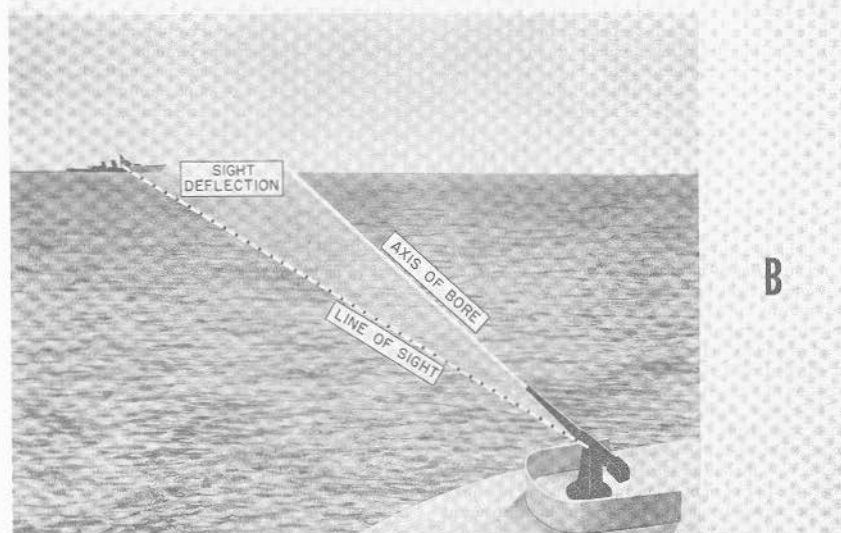
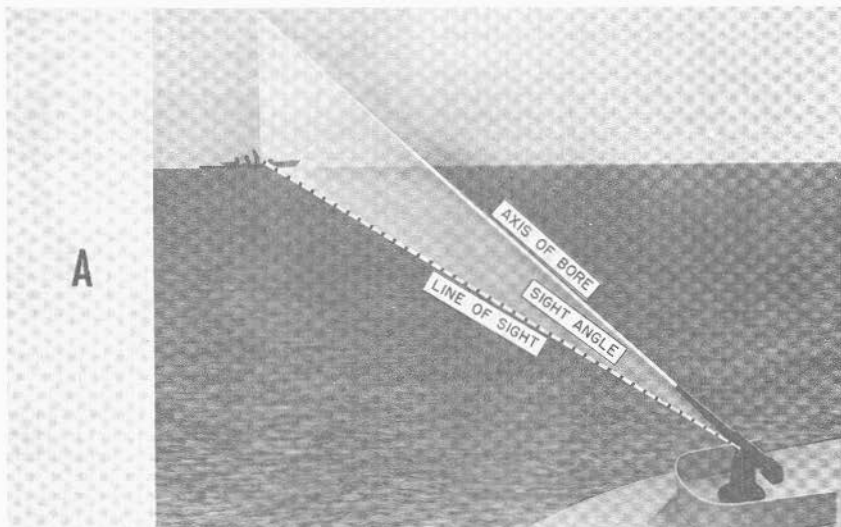

FIGURE 5B33.—Sight angle (A) and sight deflection (B).

lishes the line of sight. With no sight angle and sight deflection set, the bore axis of the gun will be directed along the line of sight.

Here the sight setter enters the picture. Using the value of sight angle or sight bar range received from the fire control system, he sets this value on the proper scale by cranking the vertical offset handcrank. This moves the pointer's and trainer's telescopes off the target—usually moving them downward.

The pointer then elevates with the elevation handwheel until he is back on target. In doing this, he elevates the gun as well as the telescope, and the bore axis of the gun is now elevated above the line of sight by the proper vertical offset (sight angle).

Likewise, when the sight setter cranks in the value of sight deflection, the trainer's and pointer's telescopes move off the target to the right or left. The trainer then puts his vertical crosshair back on the target by training with the train handwheels. This trains the entire mount, offsetting the bore axis from the line of sight by the amount of the sight deflection.

Thus the three-man team establishes the line of sight and also offsets the bore axis from the line of sight by the amounts of the sight angle and sight deflection, so that the projectile, when fired, will hit the target.

### 5B11. Types of sights

The simplest type of sight now in use is an open sight consisting of a small peephole behind a vertical rod. The line from the peephole through the top of the rod defines the line of sight. Such a sight is used at the local surface control station of the 3"/50 rapid-fire mount; it is illustrated in figure 9D9. This open sight is used to bring surface targets into the view field of the adjacent telescope; it is not primarily designed for controlling gunfire.

An almost equally simple type of open sight is the peep-and-ring sight; an example is visible in figure 9C1 installed on a 40-mm mount. The rear part of the sight is a peephole. The front part consists of concentric rings which are used not only to establish the line of sight but also to estimate lead angle for fast-moving air targets. Considerable skill and training are necessary for effective use of this sight. It is used nowadays only for local control in emergencies, or for slewing a gun mount toward the approximate location of a target.

Telescopic sights permit more accurate sighting than open sights. There are two general types—the fixed-prism and the movable-prism. In the fixed-prism type the entire telescope is moved in order to offset the line of sight. The movable-prism type need not be moved because the prisms in the instrument can be shifted to offset the line of sight. The principles of prismatic telescopes are taken up in volume 2.

A typical fixed-prism telescopic sight is shown on a 3"/50 mount, next to the open sight, in figure 9D9. Movable-prism telescopes used on 5"/38 mounts are shown in figures 8B23 and 8B24.

A third general type of sight, the lead-computing sight, has movable optical parts and computing mechanisms which automatically offset the line of sight. Lead-computing sight mechanisms are discussed in volume 2.

### 5B12. Train and elevation systems

One important respect in which today's naval gun differs from its ancestors is in the improvement in (a) the methods available for positioning it in train and elevation, and (b) the methods available for measuring its position—or, alternately, for shifting it to a prescribed position.

Some smaller old-time cannon, called swivel guns, could be trained with relative ease, but, in general, training the old-time heavy cannon that poked their muzzles through the gun ports was a matter of getting the whole gun crew to drag it ponderously a few inches to one side or the other. Only a few degrees of train were possible anyway. It was better (and far commoner) to turn the whole ship. As for elevating, the old-time guns were breech-heavy, and a quoin or wedge under the breech could be pulled out to elevate the gun, or driven in to depress it. Again, it was easier, and much commoner, to leave this alone and let the ship's roll decide the firing elevation.

Long before aircraft made such methods as hopelessly antiquated as they sound, gun mounts and turrets were equipped with mechanical gear for training and elevating the gun barrel. But the development of aircraft in war accelerated these developments.

In a modern gun mount, the trunnions are placed where the gun is approximately in balance. In conventional designs, handwheels connected through gearing to the training and elevating gear are arranged so that the pointer's handwheels are at his station on the left, and the trainer's at his station on the right. The pointer's handwheels, in gun mounts, turn a pinion which rotates a gear sector on the slide called the elevating arc. (Figure 5B34.) The trainer's handwheel, through gearing, turns a gear that engages the training circle in the stand.

In bag-type turrets, where maximum elevation is limited and the mass of the parts to be elevated is especially great, the elevating gear turns an *elevating nut* which engages a screw pivoted to the gun slide. (Figure 5B34 inset.) Turrets of the case type must be capable of much greater elevations than are practical with this type of arrangement. They therefore use an arc-and-pinion type of elevating gear.

All turrets, and mounts larger than 20-mm, use

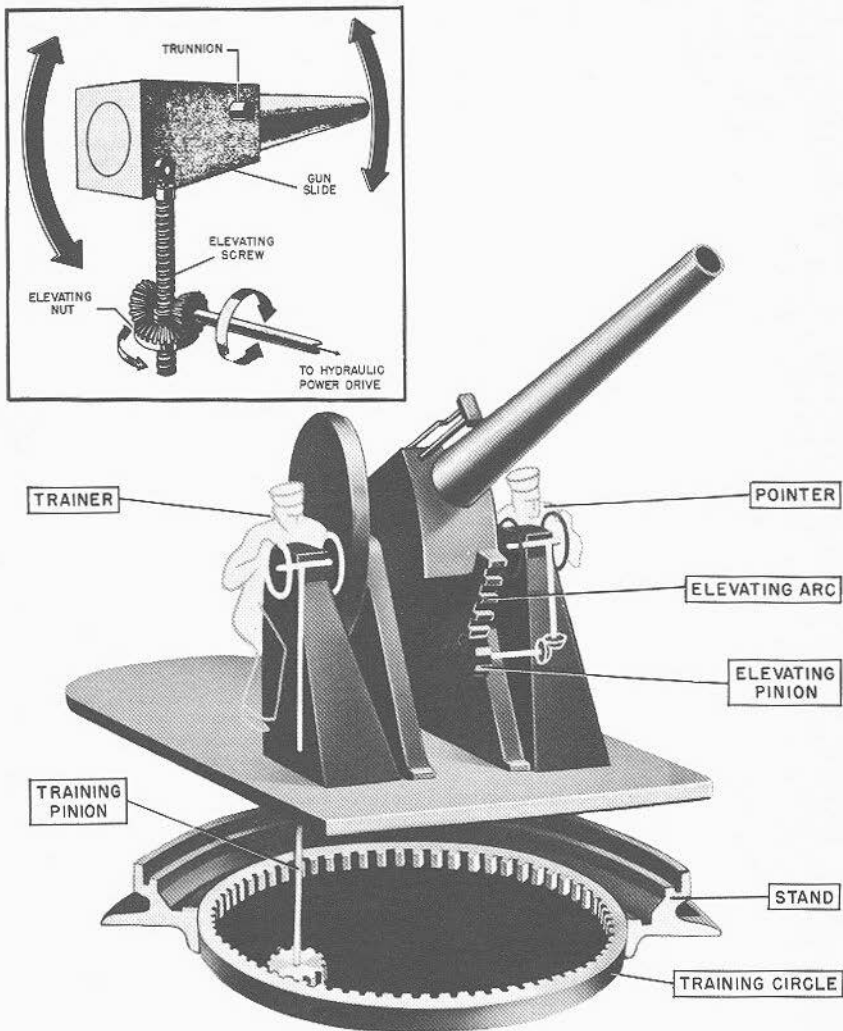

FIGURE 5B34.—Training and elevating gear. (Inset: Screw-type elevating gear.)

power drives as the normal method of positioning, though the pointer and trainer can readily switch to manual operation. Power drives and controls are discussed in more detail in chapter 10.

In some later mounts all these conventional arrangements are not followed. For example, in the automatically loaded 3"/50 mounts, the gun cannot be manually elevated and trained from the gun-laying stations on either side of the mount. The controls there provide only for operating the mount through

the power drives. The left gun layer's station is used for positioning the mount when firing on air targets; the right gun layer's station is in control for surface targets. Either station, or the director, may be in full control. When either gunlaying station is in control, mount train and elevation are both controlled by that station. Hence there is no "pointer's" station or "trainer's" station on this mount. And manual elevation and train are used only for positioning the mount for maintenance or alignment-checking purposes.

## C. Conclusion

### 5C1. General

The preceding section provided an overview of the 10 major features or characteristics which distinguish the modern gun from its predecessors. As the discussion has pointed out several times, not all of these features will be found in all modern guns—particularly in small arms and machine guns. And considerable variations in details of design from one mark and model of weapon to another. But the features described are those that are referred to elsewhere in this book as "conventional," meaning that they represent standard practice in the art of gun and mount design as it exists in the United States Navy about the middle of the 20th century. New developments and improvements in guns and mounts are, of course, always in progress. Many of these are taken up later in this series of textbooks—particularly in chapter 32, volume 3. Further details of these "conventional" features, as they pertain to specific guns and mounts, are in later chapters concerned with the different main types used in the Fleet.

### 5C2. Review of definitions

Following is a brief list of definitions which summarize in general form some key terms used in the preceding section.

*Gun.* The term *gun* properly designates the tube or barrel, but is commonly used to refer to the whole assembly of which the barrel is but a part.

*Mount.* This is the entire system between the gun and the ship's structure which supports the gun, secures it to the ship's structure, and provides for its elevation, train, and (in guns larger than 20-mm) recoil and counterrecoil. There are several types of mounts, but all of them must accomplish these functions. Larger mounts have other functions as well.

*Train.* The train of a gun is the position of the axis of the gun's bore in azimuth (or in a plane parallel to the deck), as measured from the ship's centerline. *Training* the gun is rotating it in azimuth. The *trainer* is the person who controls the training of the

gun. The *training gear* is the equipment used to train the gun.

*Elevation.* The elevation of a gun is the angle that the gun bore axis makes with the deck, measured perpendicular to the deck. *Elevating* the gun is increasing this angle; *depressing* the gun is decreasing this angle. The *elevating gear* is the equipment used to move the gun in elevation. The term *pointing* has the same meaning as the terms elevating and depressing combined. The *pointer* is the person who controls the elevation or pointing of the gun.

*Recoil.* Recoil is the force tending to push the gun to the rear as the projectile is discharged. It is the gun's reaction to firing. Recoil is also the rearward movement of the gun. The *recoil mechanism* is the equipment used to control the gun recoil. Recoiling parts are those that move with the gun in recoil and counterrecoil.

*Counterrecoil.* Counterrecoil is the forward movement of the gun after recoil which returns the gun to its original firing position. The *counterrecoil mechanism* (also known as the recuperator) is the equipment that returns the gun to its firing position.

*In battery.* A gun in its firing position as regards recoil and counterrecoil is said to be in battery. A gun moves out of battery during recoil and returns to battery during counterrecoil. *Recoil position* is the rearmost position of the recoiling parts in recoil movement.

*Housing.* The housing of a gun is a generally box-shaped structure joined to the gun barrel with a bayonet-type joint. On most intermediate-caliber guns it houses the breech mechanism. Since it is attached to the gun barrel, it is a recoiling part. Major-caliber bag guns have no housing; these have yokes, which, in general, perform a similar function. (See art. 7B1.)

*Slide.* On all guns larger than 20-mm, the slide is the structural part which supports the gun, housing, and other recoiling parts, and permits them to move in recoil. The slide will be discussed further in the next section, where it is taken up as part of the mount.

**Automatic guns.** Automatic guns are case guns in which some of the energy of the propellant explosion is used to open the breech, eject the empty case, and operate the device which automatically loads another round of ammunition. The gun can continue to fire so long as ammunition is supplied and the trigger is operated.

**Semiautomatic guns.** Semiautomatic guns are case guns in which some of the energy of the propellant explosion is used to open the breech, eject the empty case, and automatically close the breech when another round is loaded. Semiautomatic guns, unlike automatic guns, must be loaded either by hand or by auxiliary equipment.

**Nonautomatic guns.** Nonautomatic guns are those in which none of the energy of the propellant is used to perform breech opening, closing, or loading functions. All bag guns are of this type.

**Rapid-fire guns.** Rapid-fire (RF) guns are those in which loading, firing, empty-case ejection, and breech operation are performed automatically but are powered by a source of energy other than the propelling charge.

**Axis of bore.** The axis of the bore is a straight line passing through the center of the gun bore.

### 5C3. Designation of guns by caliber

The caliber of a gun (the diameter of its bore measured to the tops of the lands) is expressed in inches or millimeters. For all guns of caliber 3-inch and above, the length of the gun barrel is customarily expressed by dividing the length of the bore plus the length of the chamber by the diameter of the bore. Thus a 3"/50 caliber gun barrel has a caliber of 3 inches and is 50 calibers or 150 inches long. Guns of calibers

less than 3 inches are not usually spoken of as being so many calibers long.

Guns are usually designated by (1) their caliber in inches, followed by the length of the gun in calibers and by *mark* and *modification* numbers, or by (2) the diameter of the gun in millimeters followed by the mark and modification numbers. Thus there are 16-inch 50-caliber Guns Mark 1 Mod 1, and 40-millimeter Guns Mark 1, Mod 1.

Guns are classified according to bore diameter:

1. *Major-caliber*—8 inches or larger.
2. *Intermediate-caliber*—greater than 4 and less than 8 inches.
3. *Minor-caliber*—greater than 0.60 inch but not more than 4 inches.
4. *Small arms*—0.60 inch or smaller.

### 5C4. Guns in service

Guns most likely to be found on Navy ships today are:

<i>Guns</i>	<i>Carried on</i>
16"/50 cal.....	Battleships
16"/45 cal.....	Same
12"/50 cal.....	Large cruisers
8"/35 cal.....	Heavy cruisers
6"/47 cal.....	Light cruisers
5"/54 cal.....	Large carriers, destroyers, and frigates
5"/38 cal.....	Battleships, cruisers, destroyers, carriers, and auxiliaries
5"/25 cal.....	Submarines
3"/50 cal.....	Any ship from patrol craft to battleship
40-mm.....	Same
20-mm.....	Same

## Chapter 6

# GUN BARRELS AND INTERIOR BALLISTICS

### A. Introduction

#### 6A1. Scope of this chapter

The preceding chapter has already defined a gun as a tube designed to discharge a projectile at high velocity by the gas pressure produced by a propellant in the tube. Commonly, the term *gun* applies to the entire assembly of which the barrel is but one part.

In this chapter, *gun*, *tube*, or *barrel* designates the gun tube only, and not the remainder of the *gun assembly*, which includes, in addition, the mount and other parts described in the preceding chapter.

This chapter is concerned with gun barrel construction and maintenance, and with interior ballistics—what happens inside the gun when it is fired.

### B. Elements of Gun Design and Maintenance

#### 6B1. Modern requirements for gun power

Present requirements for guns demand muzzle velocities of from 2,500 to 3,500 fps. Lower velocities give less striking energy. More important still, a projectile fired at low velocity would describe a curve so high in the air, for long ranges, that hits could not be made unless the range were known with great accuracy. Since the accurate determination of range is a critical problem in naval gunnery, the high-power gun is a necessity. High velocity of a projectile is produced, of course, by high pressure upon it while traveling through the bore.

A gun may be considered as a tube designed to withstand a given pressure from within. In constructing such a tube, we must first consider what pressures it will have to withstand at the various points of its length, and then make it strong enough to insure perfect safety. The bore should also be of such material as to stand the wear and tear of firing a large number of rounds without being so damaged by expansion or abrasion as to interfere with the shooting.

#### 6B2. Stresses in a gun cylinder

Considering a gun only as a cylinder, we find that the two principal stresses (fig. 6B1) to which such a cylinder is subjected upon the explosion of a charge are:

1. A circumferential or *tangential stress* or tension, coupled with a *radial stress*, tending to split the gun open longitudinally.

2. A *longitudinal stress* tending to pull the gun apart in the direction of its length.

Experiments have shown that the greatest stress on the metal of the gun is the tensile stress set up in the direction of its circumference by powder gas pressure. In addition, the gun also experiences a longitudinal stress of relatively small value. If this longitudinal stress may be considered constant (and in guns it may be so considered without great error) we may lay down the first of "Lamé's laws," as follows:

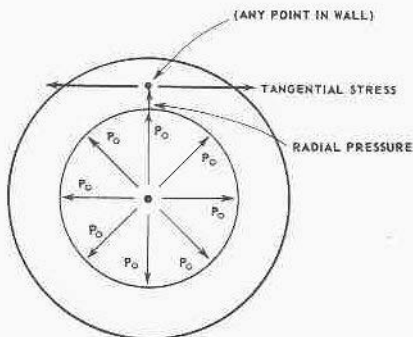

Copyright 1939 by the U. S. Naval Institute  
FIGURE 6B1.—Forces in a gun cylinder.

At any point whatever, in a cylinder under fluid pressure, the sum of the tangential tension and the radial pressure varies inversely as the square of the radius.

This law says, in effect, that in a simple hollow cylinder under internal pressure, points in the metal close to the bore experience a large proportion of the stress, whereas those at a greater radius experience only a small proportion. This means that in a simple hollow cylinder composed throughout of metal of homogeneous physical properties, we soon reach a limit beyond which any thickness of wall aids but little in enabling the cylinder to withstand pressure.

Hence a modern gun would not be sufficiently strong to withstand the required pressure if made of a single simple hollow cylinder, however thick. But the gun must be built on a principle which will enable it to withstand more internal pressure than could be withstood by the simple cylinder type of construction. The problem is to make the outer layers take a proper proportion of the stress. In one modern solution to the problem, the gun is constructed of layers of metal. The layers nearer the bore are held under an initial compression by the tension of the outer layers. Thus, when the gun is fired, the inner layers must first be expanded sufficiently to remove the initial compression before they begin to experience a positive tension or

stretch, while the expansion is continuously resisted by the tension of the outer layers.

### 6B3. Properties of gun steel

Before considering the construction of a gun according to this principle, it will be necessary to examine some of the properties of gun steel which have not yet been considered. Gun steel is elastic within limits: thus, if a stress is applied so as to set up a strain (deformation or change in dimension) not exceeding the elastic limit of strain of the steel, then the steel will return to its original shape and dimensions when the stress is removed. It is then said to have been worked *within its elastic range*. However, when the elastic limit of strain has been reached, if the stress is increased the steel will yield rather suddenly and suffer a comparatively large strain without further increase in stress. Thereafter increase in stress will still further increase strain. The steel is now being worked in its *semiplastic range*. (If the stress is still further increased the strain will go beyond the semiplastic range and the steel will give rapidly and fracture, even with decrease of load.) The important point is that the steel has now received a *permanent set* or deformation. *Nevertheless, it will attempt to return to its former dimensions when the stress is removed.* In other

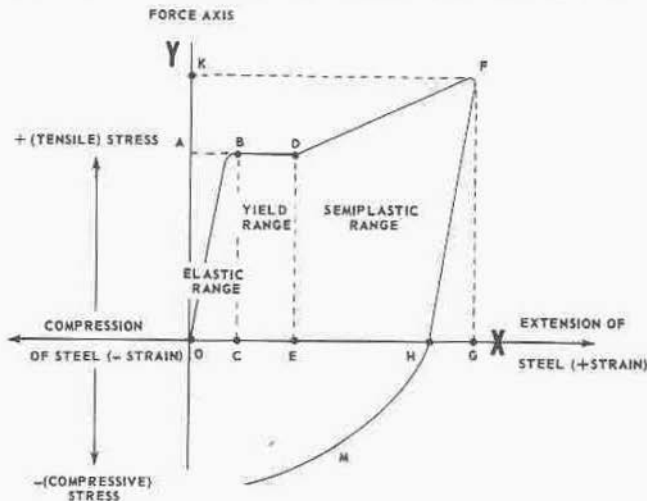

Copyright 1929 by the U. S. Naval Institute

FIGURE 6B2.—Stress and strain in a gun cylinder.

words, it has suffered a deformation that is *permanent but elastic*.

These properties of gun steel are plotted in figure 6B2, in which the ordinates, measured along OY, represent the stresses applied to a test piece, and the abscissas, measured along OX, represent the corresponding strains set up. The curve is drawn only to show tension stresses causing extension strain in the steel, but it could be shown that the steel behaves similarly under compression stresses causing compressive strains.

As the stress is raised from O to A, the steel is strained by the amount OC. If the load is increased slightly, the steel yields suddenly and suffers the additional strain CE at practically constant load. A further increase in the load to K causes an additional strain EG. The behavior of the steel thus far is represented by the curve OBDK.

If the load is now removed, the curve is seen to return, not to the origin but to the point H, the line FH being about parallel to OB. The steel has taken the permanent deformation, or strain, OH but still has elastic properties, as is shown by the decrease in strain from G to H upon removal of the load. HG is somewhat larger than OC. If the same test piece is again stressed, a stress equal to OK will be required to strain it by the amount HG; for purposes of such a second stress, H may be considered to be at the origin.

From the above, it may be seen that the steel has acquired two important new properties:

(1) It has received a permanent deformation, or strain, and will resist a compression stress tending to compress it to its former dimension (curve HM shows this action).

(2) It has changed its physical qualities in that the application of a stress beyond its original elastic limit, has given it a new elastic limit practically equal to the stress it has sustained.

Now consider the application of this principle to gun construction.

#### 6B4. Built-up guns

In the simplest built-up gun we begin with an inner steel tube of outer diameter  $d$ , and place around it a cylindrical jacket of inner diameter  $d-s$ .  $s$  is small—on the order of 0.01 in.;  $s$  is called the *shrinkage*.

The usual method of doing this is to heat the jacket, thereby expanding it, and to slip it over the cold tube, allowing it to cool and shrink in place. The result is that the tube receives a strain in compression (negative extension), because of the shrinkage of the jacket upon it, while the jacket receives a strain in extension, being unable to shrink to its former size. These strains are well within the elastic limit of strain of the steel. We have here, then, not an initially unstrained steel,

but a compound cylinder of two members, the inner of which has an initial strain in compression (negative) and the outer an initial strain in extension (positive).

When powder gas pressure (stress) is applied in the bore of such a compound cylinder, the pressure must first expand the tube enough to remove the initial strain of compression before it can continue the expansion toward the elastic limit of extension of the tube. Such expansion is continuously opposed by the jacket, which is pressing inward. This action may be stated in the following principle:

If any pressure be applied to a compound cylinder, the strain at each point will be the *algebraic sum* of the strain at the point before the pressure was applied and the strain which the same pressure could cause at the corresponding point in a simple cylinder, of the same dimensions as the compound one.

In a compound cylinder, according to this rule, the inner layer receives less strain in firing than would be received by the corresponding layer in a simple cylinder, for the original compression must first be overcome before any positive strain (extension) can be introduced. Correspondingly, the outer layer receives more strain than it would in a simple cylinder plus the original strain in extension that it receives in construction. The stress felt by the different layers of the gun is then no longer inversely proportional to the square of the radius according to Lamé's law, but instead is more evenly apportioned among the layers of metal.

This principle is applied in the *built-up gun*, which was briefly described in the preceding chapter, and is illustrated in figure 6B3. The principle of prestressing by shrinkage has its limits of application, however. Regardless of whether strains are set up by firing or by prestressing (shrinkage), the following limiting principle applies:

*No fiber of any cylinder of a built-up gun must be strained beyond the elastic limit of the metal of that cylinder.*

In a built-up gun, the outer cylinders, or *hoops*, are heated and assembled one at a time on the tube. As the hoops cool, they shrink, and tightly grip the cylinders within them. The locking rings are then added to prevent longitudinal movement of the hoops. After the hoops and locking rings are assembled on the tube, the entire assembly is heated and shrunk on a liner. The 16-inch gun is an example of this construction.

The liner, which carries the rifling, is usually thinner than the tube. It is, therefore, not to be considered a major strength member, since all but a small part of the strain is transmitted through the liner to the tube and hoops. The liner can be replaced when the rifling has worn down, without sacrificing the other

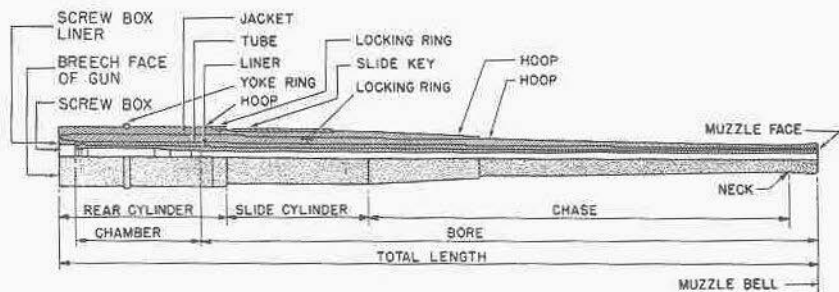

FIGURE 6B3—Built-up major caliber gun. (Cross section.)

parts of the barrel which have a much longer service life.

The assembled barrel forms a cylinder within which high pressure is developed as the charge explodes. The effect of the pressure is greatest on the inner cylinder, and diminishes rapidly as it proceeds outward. If the outer hoops were assembled over the tube without shrinkage, they would be subjected to less strain than the tube and the strength of gun would be little greater than the strength of the tube. However, the shrinkage of the hoops squeezes the tube, at the same time stretching the hoops. The safe pressure of explosion can then be increased, for it must overcome the squeeze before it can stretch the tube. The shrinkage is so calculated that each hoop carries a share of the strain.

### 6B5. Radially expanded guns

A gun made from a single cylinder which has been subjected to a radial-expansion process is called a *radially expanded monobloc gun*. In this process the gun forging is bored to a diameter somewhat less than the finished dimension, and turned down on the outside to something greater than its finished diameter. Hydraulic pressure is then applied to the bore. By Lamé's law the metal at various points through the wall of the gun will experience stresses which are inversely proportional to the square of their radii. The pressure in the bore is increased in steps, until a thin, indefinite layer of metal nearest the bore is brought to its elastic limit of strain. At this time all the other (imaginary) layers of metal in the forging are also strained, but all within their elastic limit, and the amount of strain decreases regularly as we consider layers of the metal more and more remote from the bore.

The pressure is now increased so that the bore layer is strained beyond its elastic limit, the layer next out-

side the bore layer is brought just to its elastic limit, and the tension in all the other layers is increased. Still further increase of pressure increases the permanent strain in the bore layer (which is now being worked in the portion of the curve BDF, fig. 6B2), strains the second layer beyond its elastic limit, brings a third layer up to its elastic limit, and increases the tension in all the other layers. The increase in pressure is continued until the outside layer of metal just reaches its elastic limit of strain, and this pressure is held for a time. This pressure is considerably greater than the pressure which the gun will be called upon to withstand when fired.

When the pressure is removed and the metal allowed to return to a state of rest, the physical condition of the forging is as follows:

1. The bore layer, which has experienced the greatest stress and therefore received the *greatest permanent strain*, is pressing outward upon the second layer, for it tends to be larger than the second layer. Having received the greatest stress, it has a greater permanent-and-elastic limit than the second layer, and a greater elasticity.
2. Conversely, the second layer, having received slightly less stress, is strained slightly less, has less elasticity, and is pressing inward upon the first layer.
3. Continuing outward, the third layer bears the same relation to the second layer as the second does to the first, and so on.

The net result is that the inner layers are being pressed upon by the outer layers, and receive a strain in compression, as in the curve HM, figure 6B2, but they resist this pressing inward by pressing outward, and thereby place the outer layer in a state of tension. We then have a gun constructed by a process of self-hooping (*autofrettage*), made as if composed of an infinite number of infinitely thin hoops shrunk to-

gether and therefore demonstrating the principle of initial tensions.

The radial-expansion process results in a cylinder in which the change from squeeze on the inner layer to stretch of the outer layer is uniform. The change in a built-up gun is in steps from hoop to hoop, and the strength of the metal is not fully utilized. The metal in a radially expanded gun is used much more efficiently; therefore, radially expanded guns weigh less than built-up guns of the same strength. The reduced weight of the barrel makes possible a lighter gun assembly.

The radial-expansion process permits faster gun production at lower cost. With the saving in weight, this makes radially expanded preferable to built-up guns. However, the process is limited at present to moderate-size guns because of the difficulty of obtaining a single forging large enough for those of major caliber. Typical monobloc barrels are found in the 5"/38 caliber guns and the 6"/47 caliber guns.

#### 6B6. Combination guns

The built-up and radially expanded methods may also be incorporated in a single gun. Thus the difficulty of obtaining a single forging big enough for the larger guns can be overcome. The 8"/55 caliber gun, for example, has a jacket shrunk on a radially expanded tube.

#### 6B7. Simple one-piece guns

Many small guns such as the 40- and 20-mm are made from a single steel forging which requires neither radial expansion nor hoops. The pressures developed

per square inch in small guns may be higher than those in large guns, but this may be compensated by increasing the size of the forging, which is not excessively large in any event. This type of construction is, at the present time, limited to guns of 3-inch caliber and smaller; but the development of steels with greater metallurgical strength may make it applicable to large guns in the future.

#### 6B8. Rifling

Chapter 5 explained the nature and purpose of rifling. Figure 6B4 shows in a detailed cross section the chamber of a gun, a seated projectile, and the origin of rifling, and figure 6B5 shows details of gun rifling. The velocity of projectile rotation when it leaves the muzzle of a gun depends on the twist of the rifling and the velocity of the projectile. A 16"/50 projectile turns at about 4,000 rpm when it leaves the muzzle, and a 40-mm projectile turns at about 40,000 rpm.

In guns 5-inch and smaller, rifling is cut into the gun tube's bore. Larger guns may be fitted with tubular *loose liners*, which can be replaced with relative ease when the rifling is worn out. The rate of rifling wear tends to increase with caliber.

#### 6B9. Differences in construction between case and bag guns

Nowadays only large guns (8-inch and up) use bag ammunition. Hence bag guns are generally of the built-up type, while a case gun may be monobloc or built-up, depending on size. Other differences in con-

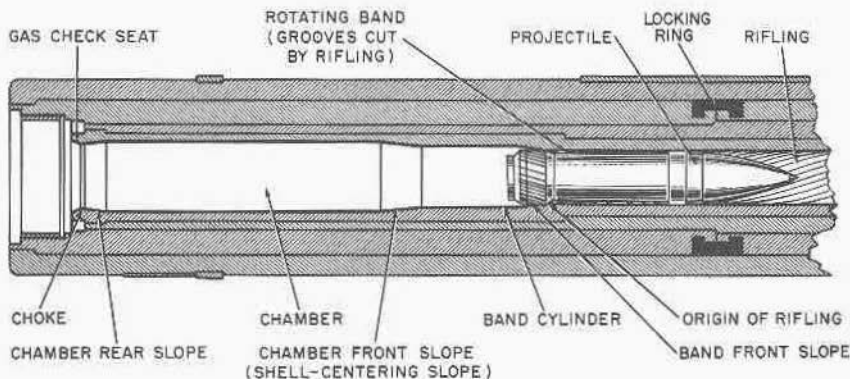

FIGURE 6B4.—Details of breech and chamber (bag gun), with projectile seated.

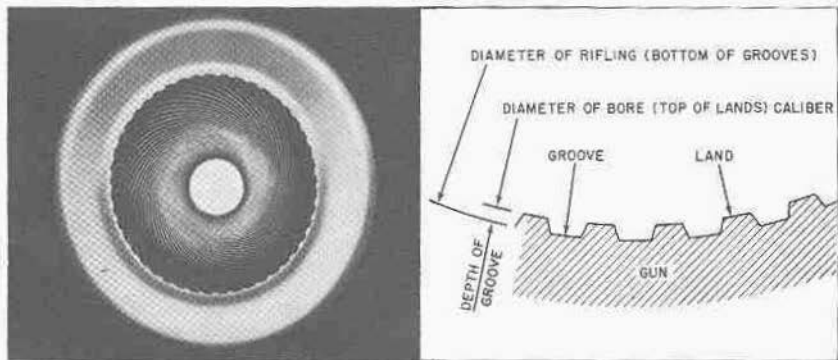

FIGURE 6B5.—Details of gun rifling.

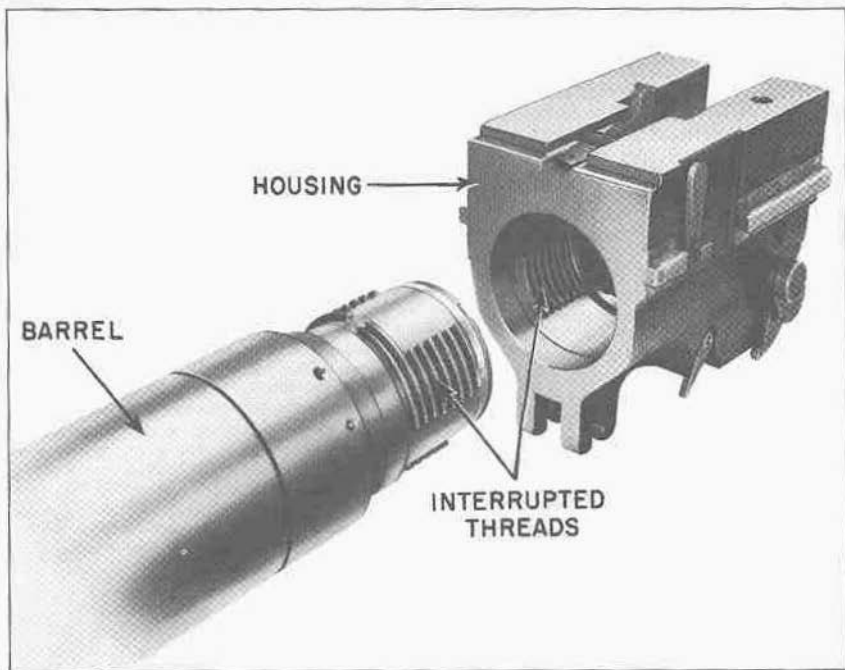

FIGURE 6B6.—Housing-to-barrel joint for case gun.

struction between case and bag guns are concerned only with the breech structure.

The breech end of a case gun generally terminates in an interrupted-screw thread which meshes with a similar thread in the gun housing. Figure 6B6 illustrates a typical arrangement, which is easy to recognize as an application of the interrupted-screw principle discussed in the preceding chapter. A key prevents rotation of the barrel with respect to the housing after engagement.

The breech end of a bag gun has a *yoke*, a massive metal ring, surrounding it. The yoke provides a connection between the barrel and other recoiling parts and the recoil and counterrecoil systems. Shoulders on the gun prevent movement with respect to the yoke. The yoke serves also as a counterweight to bring the gun's center of gravity toward the breech. The after end of the gun chamber contains the *screw-box liner* or *screw box*, a steel insert whose threaded interior surface meshes with the stepped thread of the breech plug. The liner is locked in position by keep screws, and can be replaced if worn or damaged. It is illustrated in the chapter on turrets.

#### 6B10. Care of bore and chamber

Complete instructions for the regular inspection and cleaning of gun barrels will be found in the *Bureau of Ordnance Manual* and other publications of that bureau. Only a few of the more important aspects of gun maintenance will be discussed here.

Great heat, great pressure, and complicated chemical changes accompany the burning of the charge. Some but not all of the residue of the burning is blown out of the muzzle after the projectile. That which remains in the gun is in the form of a corrosive salt. Standard procedure is to remove this "fouling" by washing out the bore with a hot soda solution and applying a thin film of oil before securing until the next firing. Since the advent of chromium plating of gun bores, *powder fouling* is much less of a problem.

Dirt in a gun bore is not only an invitation to corrosion but a source of positive danger because, if it offers sufficient resistance to the passage of the projectile, excessive pressure may pile up at a point where the design of the gun will not withstand it. To guard against the accidental admission of dirt, spray, or moisture into the gun, a solid muzzle plug, rather like a cork, called a *tompson* (pronounced *tom-kin*), is inserted. This is only a partial solution, because under certain weather conditions considerable condensation accumulates in the bore. This moisture is also a source of corrosion danger. In fair, dry weather, tompions are removed to air out the barrels.

Tompson cannot be used under combat conditions,

because of the possibility of one inadvertently remaining in a gun when firing. However, dirt and water, especially salt water, must be kept out of the gun; so canvas, or in the case of small calibers, plastic, muzzle covers are used. In an emergency, the projectile can be forced through such covers without bursting the barrel. This procedure is, of course, subject to certain limitations. Projectiles with supersensitive nose fuzes cannot be fired through muzzle covers of any sort. In cold-weather operations, when canvas covers may become ice coated, they should be removed before firing.

More immediately dangerous than corrosion or dirt is metallic constriction of the bore. Before and after each firing, barrels are tested for this condition with a plug gage, which is a steel cylinder accurately machined to slightly under the diameter of the bore. If at any time it is discovered that the plug gage will not pass through the bore without undue forcing, the nature of the constriction must be determined.

One type of constriction is copping consisting of metallic deposits on the bore, left behind by the rotating bands of projectiles. Even an amount of copper too slight to impede the projectile will affect its accuracy. Metallic lead foil in the powder charge, while increasing muzzle flash, has been used in some powders to control copping. The lead, reduced either to a molten and thinly dispersed state or to a gaseous one, serves as a lubricant on top of which copper deposits will not form. Once so treated, new or increased deposits of copper will not occur, and the existing deposits will be abraded or swept along by the passing projectile. The firing of the older type of star shell, which has a lead gasket between its base and its flanged base plug, has a similar effect. The newest propellants have incorporated into their composition a trace of lead carbonate, much more readily reducible than even the finest metallic lead foil.

Copper fouling may also be removed with an acid treatment, but this is not authorized for shipboard use. Approved mechanical means for meeting this condition consist of rubbing away the constriction with a wire bore brush or with a lapping head such as shown in figure 6B7. The head is covered with a fine abrasive material and is drawn back and forth at the location of the constriction until the plug gage can be passed through without forcing. Special scraping or decopping heads, fitted with steel blades, are supplied for certain guns.



FIGURE 6B7.—Plug gage and lapping head.

Steel constriction also occurs in built-up guns. The friction of the projectile on the bore tends to drag the liner along with it, which tendency is resisted by the shoulders of the liner and the tube. With continued firing, the shoulders of the liner tend to over-ride those of the tube, thereby forcing the walls of the

liner inward. As with coppering, steel constriction can be removed by lapping and polishing.

Continued firing may also elongate the liner and cause it to protrude from the muzzle. This is not a serious condition. When the extension amounts to as much as half an inch, it is simply cut off.

## C. Interior Ballistics

### 6C1. Ballistics

Ballistics is the science of the motion of projectiles. It is divided into two branches, *interior* and *exterior* ballistics. Interior ballistics is that branch of the science which treats of the motion of the projectile while in the gun. The *initial velocity*—i. e., the speed of the projectile at the time it leaves the muzzle of the gun—is a result of the various forces which are involved in the general term, interior ballistics. Exterior ballistics pertains to the projectile after it leaves the gun and will be considered in the fire control problem, discussed in Volume 2. Obviously the initial velocity is the one value common to both interior and exterior ballistics.

Gun design is essentially a compromise. The gunner naturally desires a maximum velocity for great range and flat trajectory; the designer must consider the strength of his gun and desires the minimum wear or erosion therein. The velocity finally agreed upon must take into consideration both of these requirements. To determine the velocity of the projectile at the muzzle of the gun requires a study of (1) the combustion of the powder, (2) the pressures developed within the gun, (3) the variations in pressures and velocities with changes in any of the "conditions of loading", and (4) erosion at the bore. Such is the field of interior ballistics.

### 6C2. Propellants

Propelling charges are designed to burn in the chamber of the gun in such a way that the maximum veloc-

ity may be imparted to the projectile without excessive heat, pressure, or erosion. To accomplish this the thrust against the base of the projectile must be uniform. The most efficient propellant for a gun would be so balanced that the charge is entirely consumed *immediately before* the projectile leaves the muzzle.

A "high explosive" is one capable of instantaneous evolution of masses of highly heated gases. A "low explosive," such as smokeless powder, is not detonated, but is burned in an appreciable length of time, causing a comparatively gradual evolution of gases, with consequently much less shock and wear to the container. From this may readily be seen the impracticability of using high explosives for propelling charges in guns, and the suitability thereof of smokeless powder. Figure 6C2 illustrates this fact.

A propelling charge must be suited to the gun in which it is to be used; that is, the speed of burning of the charge must, within close limits, be appropriate to the specific gun. Several factors are involved; for example, the size of the grain, the shape, the number of perforations, the web thickness between perforations, the percentage of nitration, the moisture content, the remaining volatiles, and the stabilizer used. Of these, grain size is the most easily changed, and it is varied to control the rate of burning. The percentage of nitration is fixed. The moisture content and the remaining volatiles vary with grain size. Diphenylamine stabilizer absorbs nitrous vapors, the first prod-

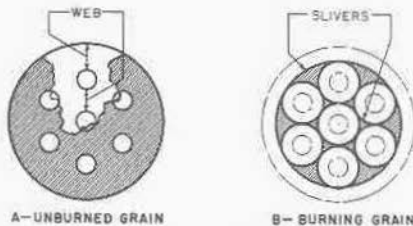

FIGURE 6C1.—Burning surface of perforated powders.

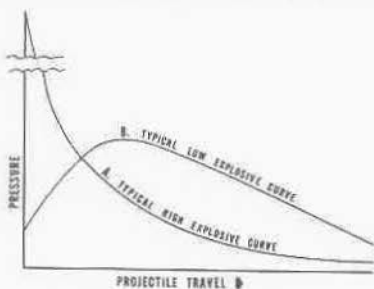

FIGURE 6C2.—Gun pressure curves.

acts of decomposition, the pressure of which would otherwise cause the generation of more vapors at a continually increasing rate.

The grain shape of gun propelling charges is normally cylindrical. The web thickness and the number of perforations vary with the size of the grain. For guns smaller than 40-mm the number of perforations is 1 or none, and for larger guns the number of perforations is usually 7. See figure 6C1.

A propellant's *potential* is defined as the total work that could be performed by the gases of combustion while expanding from the solid state to the space they would occupy when fully expanded to atmospheric pressure and when cooled to a specified temperature. It is of interest to note that there is less stored-up energy in smokeless powder than in most common fuels. The chief characteristic of an explosive lies in its enormous *rate* of delivery rather than in its *amount* of delivery. In the average conventional gun, some 60 percent of the potential disappears in muzzle loss; 30 percent is transmitted to the projectile, and all other losses—such as heating the projectile and gun, causing the gun to recoil, and so forth—amount to about 10 percent.

### 6C3. Gun strength-pressure relationship

To establish the basic principles of gun design, study figure 6C3. The figure may be taken as typical of the strength-pressure relationship in modern guns. Note that the high breech strength is carried well forward of the point of maximum pressure. The gun strength at every point must exceed the powder pressure at that point by an amount that will provide a suitable margin of safety.

The curve as it appears in figure 6C2 shows pressure beginning at a value well above zero. This indicates the pressure build-up that occurs after the propelling

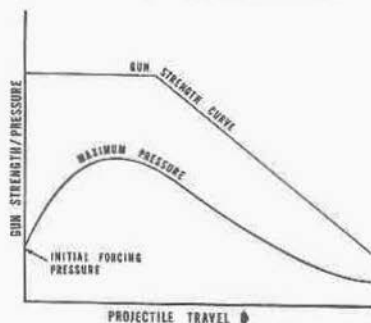

FIGURE 6C3.—Typical gun strength and pressure curves.

charge begins to burn but before the projectile begins to move. (The x-axis in the figure represents *projectile movement in the bore*, not time or bore length.) The projectile begins to move only after the propellant gas reaches the *initial forcing pressure* required to initiate movement of the projectile in spite of projectile inertia and the engagement of the rotating band in the rifling.

Note that the gun strength curve is represented as a straight horizontal line above the area between the point of initial forcing pressure and the point of maximum pressure. It does not vary in parallel with pressure curve. The reason is that the same pressure that the expanding gases exert against the base of the projectile is exerted equally against all interior surfaces of the gun behind the projectile. Hence the breech part of the barrel must be designed for the maximum stress to be imposed.

After the projectile passes the point of maximum pressure, it continues to be accelerated by gas pressure until it leaves the muzzle. The total area under the curve, up to the point where the projectile leaves the gun, is a rough measure of initial velocity, and the pressure remaining at the muzzle is an indication of the muzzle loss. A high muzzle pressure increases muzzle flash.

### 6C4. Changes in "conditions of loading"

By "conditions of loading" are meant the powder used, the weight of charge, the density of loading, the volume and form of the powder chamber, and the weight of the projectile.

a. *Powder used and weight of charge.* Powders are spoken of as *quick* and *slow* powders, these terms being used only in reference to a particular gun. A slow powder is one in which the rate of combustion is comparatively slow, and a quick powder is one in which the

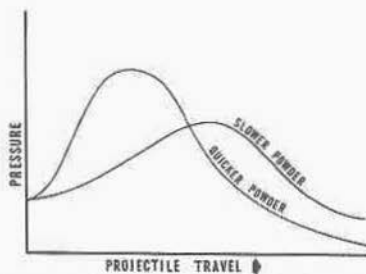

FIGURE 6C4.—Typical gun pressure curves showing variations due to quickness of powder, same weight of charge.

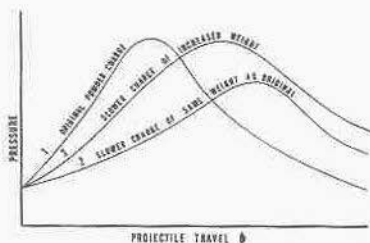

FIGURE 6C5.—Typical gun pressure curves showing methods of obtaining increased muzzle velocity in a gun without increasing maximum pressure.

rate of combustion is comparatively rapid. For instance, a small-grain powder is quicker than a larger grain of the same shape, since all the grains would be consumed in a shorter time. Not only will the larger grain increase the time required for burning the charge, but it will also cause maximum pressure to be lower and to be reached later in the travel of the projectile. The gun pressure curves shown in figure 6C4 compare slow powders and quick powders where the same weight of charge was used. Within limits, the muzzle velocity for a particular gun may be increased without causing excessive pressure by increasing the size of the charge and at the same time using a powder that burns more slowly. See figure 6C5.

b. *Density of loading.* Density of loading is the ratio of the weight of the charge of powder to that of the volume of water which, at standard temperature, would fill the powder chamber. It is a measure of the amount of space in which the gases of combustion may expand before the projectile begins to move. See figure 6C6.

It follows that a high density of loading leaves but

little space for initial expansion, and consequently that the pressure builds up rapidly. Therefore the maximum pressure behind the projectile is reached early in the projectile's movement through the bore. With a lower density of loading, more expansion of the gases may take place before the projectile starts to move; the maximum pressure is achieved later, and this maximum is necessarily lower than that resulting from high density of loading. Other factors remaining equal, increased density of loading increases maximum pressure, muzzle velocity, and muzzle loss.

The densities of loading at present vary between 0.4 and 0.7, depending on the caliber of the gun and on whether the charge is case, stacked bag, or unstacked bag. Since the specific gravity of smokeless powder is about 1.6, the following relationship holds:

$$\text{Density of loading} = 1.6 v,$$

where

$v$  = the proportion of the total chamber volume which is filled by the charge.

Hence it is apparent that a loading density of 0.4 would require a charge filling 25 percent of the chamber volume, and a loading density of 0.7 would require a charge filling 45 percent of the chamber volume.

When the density of loading drops markedly below the above figures, irregularities of muzzle velocity may be expected. This is probably due to nonuniform ignition, excessive physical displacement of the powder grains during the burning, and an abnormal burning rate. Whatever the cause, it is evident that the pressure builds up irregularly instead of smoothly, and there is real danger that the high point will be reached at the wrong time.

A practical example of this would be a projectile lodged part-way down the bore of a gun, thus greatly increasing the effective chamber volume. Not only has this the effect of greatly lowering density, thereby causing pressure waves which may build up beyond a safe limit, but it also extends the area of maximum pressure beyond the area of maximum barrel thickness. Should a normal powder charge be used to dislodge a projectile so positioned, the result would be a burst, or at least a bulge, immediately behind the projectile.

Very high density of loading, on the other hand, may cause detonation of the propelling charge, again resulting in a burst gun.

c. *Volume and form of powder chamber.* The designers of the gun, having established first the desired muzzle velocity, then the limiting maximum pressure allowable in the gun (determined from study of gun construction), can proceed to determine the volume and form of the powder chamber and the weight of the charge. Once a particular gun has been built, the volume and form of the powder chamber changes only because of erosion at the origin of rifling and improper

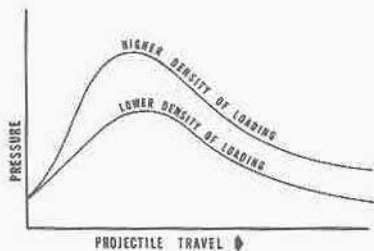

FIGURE 6C6.—Typical gun pressure curves showing variations due to density of loading.

seating of the projectile. This will cause irregular muzzle velocity. Projectiles differing in weight—for example, high-capacity and armor-piercing types—can be fired from a given gun. High-capacity projectiles, being lighter, will have a slightly higher muzzle velocity.

### 6C5. Summary

The following conclusions may be drawn from the propellant pressure curves and the foregoing discussion:

1. High explosives are not suitable for use as propellants.
2. Using the same weight of charge, a slow powder produces a smaller maximum pressure than a fast

powder, and attains this maximum pressure later in the travel of the projectile.

3. Increasing the weight of a charge of powder of a given grain size increases the maximum pressure attained and causes this maximum to occur earlier in the travel of the projectile.

4. Because of muzzle loss and irregularity of muzzle velocity, slow powders are less efficient than fast powders.

5. The muzzle velocity of a given gun may be increased within limits by using larger charges of slower propellants.

6. In general, powders designed for different classes of guns are not interchangeable.

## D. Erosion

### 6D1. Causes of erosion

The deterioration and wearing away of the bore surface by use is known as erosion. This effect is not the direct result of friction caused by the projectile in its movement down the bore. There is some uncertainty about the exact process by which the interior of a gun wears away, but it is generally agreed that the following are the principal causes:

1. The inner surface becomes intensely heated in firing, and the rush of hot gases across this hot metal has a scouring effect.
2. The hot powder gases react with the metal, changing the carbon content on the surface of the bore. Since this surface is designed with an optimum carbon content, any change results in a weakening of the metal.
3. The alternation of intense heat and rapid cooling affects the temper of the metal.
4. The explosion gases are forced into and out of the pores in the metal surface as they open and close during the expansion and contraction which accompanies such drastic temperature changes.
5. Heat cracks may develop.
6. Gases escaping around the projectile act as high-velocity jets, scouring the bore and causing damage, especially where there are heat cracks.

### 6D2. Effects of erosion

Two fundamental facts of erosion are (1) that it is always greatest at the origin of rifling, and (2) that the tops of the lands wear away faster than do the bottoms of the grooves.

Enlargement at the origin of rifling, in bag guns and guns using semifixed ammunition, tends to permit the projectile to seat farther and farther toward the muzzle. This reduces the density of loading and

therefore the muzzle velocity. To avoid this, there is a lip of slightly greater diameter at the base of the rotating band which tends to engage the forcing cone more nearly at the same point at every loading, regardless of gun wear. Naturally, this applies only to bag and semifixed ammunition, where the projectile is not positioned by the case. In all guns, however, erosion at the origin of rifling permits gas to escape around the projectile, and this in turn increases erosion.

As the lands wear, not only does more gas escape around the projectile but the rifling engraves the band less deeply, reducing materially both the initial forcing pressure and the resistance of the projectile to the gas pressure. The effect is a material drop in muzzle velocity.

### 6D3. Control of erosion

All erosion factors are related to (1) the temperature of the expanding gases and (2) the duration of their confinement in the bore. So, larger guns, with their slower powders and longer barrels, suffer more erosion per round fired than smaller guns, but the higher firing rate of the lesser guns offsets this, because it permits less cooling time between rounds.

Chromium plating of gun bores has reduced the effects of erosion, and it may be possible that in the future the use of molybdenum in this fashion will make for even better erosion resistance.

Some smaller guns are cooled by water jackets around the barrels, and experiments are under way on introducing a coolant between the tubes and the liners of larger guns. Also under development are cooler propellants. Any development that reduces the heat of explosion will aid in erosion control and, inasmuch as excessive erosion imposes much of the present limitation upon muzzle velocity, temperature

reduction appears to be a most practical approach to more effective gunnery.

#### 6D4. Gun life

Erosion, however carefully controlled, eventually terminates gun life. Though, with the exception of the larger turret installations, regunning is relatively simple, it cannot be done under combat conditions. Therefore, the duration of the effectiveness of a gun is of paramount importance.

Symptoms of the end of serviceability are: (1) loss of accuracy, (2) loss of velocity, and (3) erratic fuze actions. Naturally, a gun that does not hit its targets is no longer useful; neither is one of inadequate range and armor-piercing capacity, both of which result from velocity loss. Erratic fuze action not only undermines effectiveness but can endanger friendly personnel.

Any of these conditions can take place when the rifling no longer imparts adequate rotational velocity to stabilize the projectile in flight. In small arms, this effect can be seen when tracers are used, and a barrel should be replaced when erratic flight is observed. With larger guns, however, it is important that replacements be made before the effectiveness is seriously reduced.

Up to the present, relining guns has been a naval shipyard operation, but recent experiments indicate that it may soon be possible to use a loose liner with as much as 0.010 inch between it and the tube. This will make it possible to regun aboard ship under ac-

tive service conditions. With expendable liners, much higher muzzle velocities with their increased erosion would become acceptable.

#### 6D5. Erosion measurement

There are, for each class of gun, curves furnished to ships showing relationship between the enlargement of the bore and the initial velocity to be expected from the gun. Thus if the actual diameter is frequently checked, velocity loss becomes predictable, proper allowance for it can be made in aiming, and, of at least equal importance, barrels or liners may be replaced before their performance becomes noticeably erratic.

In some minor-caliber guns, measurement of bore enlargement is made at the origin of rifling only. This is done with a *wear gage*, which is a truncated cone that can be inserted directly in the breech. In larger guns, erosion is measured at several points in the bore with a *star gage*.

This is a simple device, consisting basically of a hollow staff with a *head* at one end and a *handle* at the other. By means of the staff, the head can be inserted in the bore to the desired point. Three removable *points*, the length of which varies with the caliber of the gun to be measured, are carried in *sockets* spaced radially 120° apart in the head. The sockets are pressed inward upon a *cone* by spiral springs and move inward or outward, at right angles to the staff, as the cone, activated by a threaded *rod*

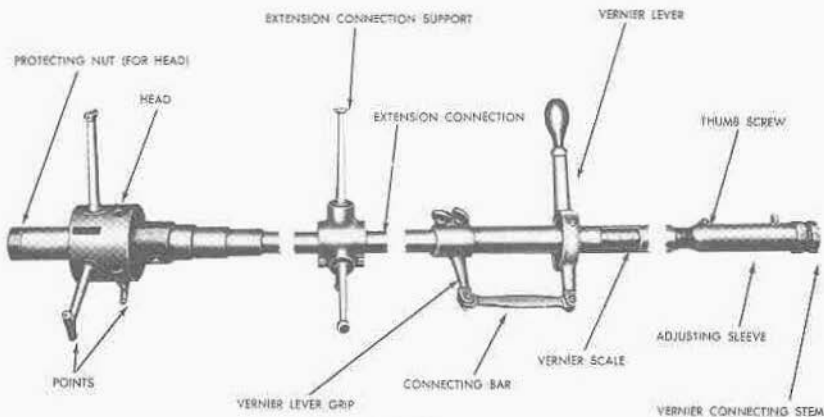

FIGURE 6D1.—The star gage.

which the hollow staff contains, is advanced or retracted. A vernier on the handle end of the staff measures this inward and outward movement of the points in thousandths of an inch.

Before use, the star gage is calibrated by inserting the points into a standard ring, accurately machined to the designed bore diameter of the gun, and setting the vernier at zero. Then, upon insertion into the bore, vernier readings directly measure bore enlargement. As a rule, two readings, 180° apart, are taken at each point of the bore to be measured.

Of these measurements, that taken immediately forward of the origin of rifling is the most important. It has been found that muzzle velocity loss is a function of bore enlargement at this point, and tables or graphs, such as those illustrated in volume 2, are predicated upon it.

Specimen curves (for 5"/38 guns Mk 12 and mods) used in figuring equivalent service rounds and velocity loss are illustrated in appendix B. One curve shows equivalent service rounds plotted against measured bore enlargement (in thousandths of an inch) at the origin of rifling. The other curve shows directly velocity loss (from the nominal standard service value of 2,600 fps) as plotted against bore enlargement at the same point. Thus, from the measurement of bore enlargement, it is possible with these curves to determine equivalent service rounds fired, and velocity loss in feet per second.

#### 6D6. Velocity loss estimation

Star gages are not carried on combatant ships, and star gaging is done only when shore- or tender-based facilities are available, however desirable it might be in theory to do it before and after every firing. After each firing, when a star gage is not available, the additional bore enlargement must be approximated.

Estimates depend upon the fact that, under normal conditions, each round fired causes a certain amount of erosion, experimentally determined for various periods in the life of the barrel. The standard unit of measurement is *equivalent service rounds* (E. S. R.). Reduced charges, which are used for such purposes as gunnery practice, have less effect than service charges. Increased charges, used for proving guns, have more effect on bore enlargement. When such charges are fired, their effect must be reduced to E. S. R.'s before

the curves can be used. For instance, it has been determined that a reduced 1,200 fs charge will cause only one-sixth the erosion of a full 2,600 fs charge. Consequently, for computation purposes, six such rounds would be regarded as one E. S. R.

The legend accompanying the graphs gives the proper method of using them. (See appendix B.) Other corrections are required when firing certain indexes of powder, but such information is included in the same Bureau of Ordnance publications as the curves.

Without periodic star gaging, the equivalent-rounds procedure would not be accurate, mainly because the typical curves take no account of the rate of fire. Rounds fired with very short cooling intervals between cause much greater erosion than the same number of rounds fired at normal intervals. For practical gunnery, however, the curves are considered sufficiently reliable for use, if no better data can be obtained.

#### 6D7. Improved methods of measuring I. V.

At proving grounds gun projectile velocity is measured by a device called a *chronograph*. In one (older) type the projectile cuts wires when it passes through two successive screens located in the trajectory at known ranges, and the exact time of each passage is recorded. This yields the projectile velocity between the screens, and from this I. V. can be reckoned. In a more recent type, the projectile passes through two magnetic coils in succession, and the induced impulses, amplified, cause sparks to pass through a rapidly moving tape. From this the elapsed time and then the I. V. can be worked out.

Both of these methods require special setups of coils or screens, careful gun placement and aim, much auxiliary equipment, specially skilled technicians, and a good deal of time. They are consequently not practical for shipboard use. But because erosion and I. V. are significant factors in fire control, the Navy has developed chronographs on far different principles which can actually measure service rounds fired on shipboard. One such design incorporates the velocity-measuring device in a fire control system. In the other, the chronograph device (which works on a different principle from those already mentioned, since it measures projectile velocity *in the gun bore*) is mounted in the barrel and on the carriage as an independent unit.

## E. New Developments in Gun Design

#### 6E1. Attainment of high muzzle velocity

Defense against modern high-speed aircraft is largely a fire control problem. Firing is at a predicted

future position of the target, and the less time the projectile spends in the air between the muzzle and the objective, the less time hostile aircraft have for defensive maneuvering. Higher muzzle velocities are

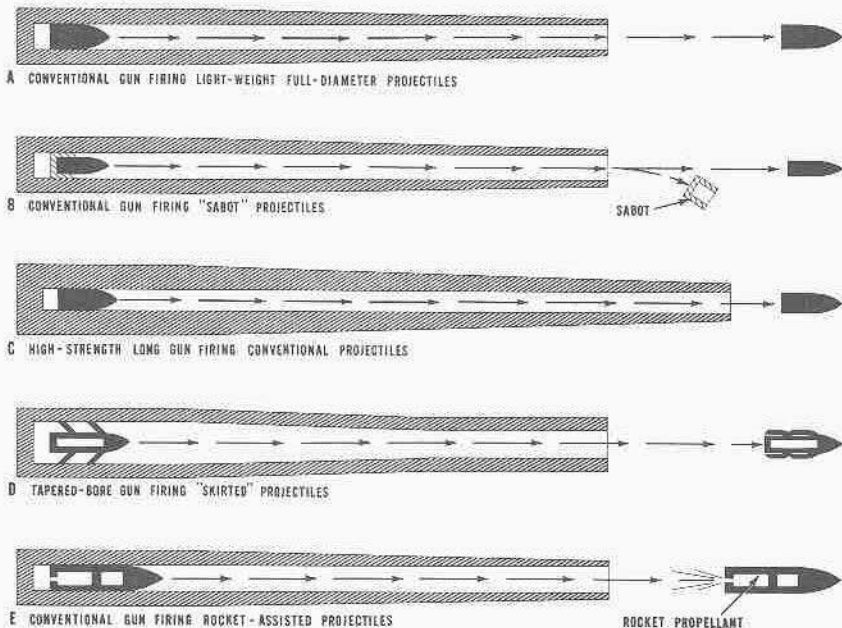

FIGURE 6E1.—Five ways of imparting high velocities to projectiles.

not the whole answer, but do contribute to the simplification of the problem.

Of the several means of achieving higher muzzle velocities, the following either were used in action in World War II or were experimented with. See figure 6E1.

*Lightweight projectiles* fired from conventional guns attained muzzle velocity of about 4,000 feet per second as compared with 2,700 for the standard projectiles. Air resistance, however, so quickly retarded this type of projectile that it was of slight use at the longer ranges prevailing in naval warfare. It was used with great effect ashore in antitank warfare, where ranges were shorter.

*Subcaliber projectiles* fired from conventional guns lightened the projectile and, at the same time, presented less surface for air resistance. This is a more slender projectile fitted with a lightweight bushing called a *sabot* which fits the gun bore and drops away after the projectile leaves the muzzle. The German army achieved muzzle velocities above 5,000 fs with guns as large as 11-inch and also fired sabot projectiles

from 90-mm antiaircraft guns. This too has disadvantages for sea use, as the discarded sabot is dangerous to nearby friendly ships.

*Conventional projectiles* fired from high-strength or extra long guns can attain a velocity limited only by the amount of pressure that the gun can withstand and by the amount of pressure that can be developed with available types of powder. Such guns would be heavier and require considerably more space aboard ship than guns which impart conventional velocities to standard projectiles.

*Tapered-bore guns* firing "skirted" projectiles have many of the advantages of the sabot without the danger to friendly personnel. This subcaliber projectile is equipped with flanges which furnish a gas seal and which are squeezed inward by a tapered reduction in the size of the bore toward the muzzle. There is some loss of accuracy and a smaller projectile is fired, but these effects are more than compensated for by the reduced time of flight. The Germans used such "squeeze-bore" guns in sizes from 20- to 75-mm and attained 4,700 fs muzzle velocities with them.

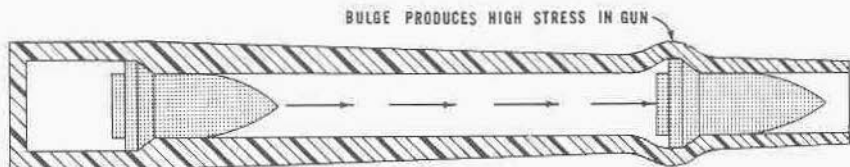

FIGURE 6E2.—Exaggerated sketch showing how the projectile causes high stresses in the gun barrel.

Rocket-assisted projectiles were used by the Germans in large guns, the rocket action being initiated during flight. The range of this projectile was greatly increased, but the space in the projectile occupied by the rocket propellant reduced the pay-load of high explosive that the projectile could carry. It appears doubtful that rocket-assisted projectiles could consistently provide the accuracy obtainable from other projectiles, but they are worthy of consideration for firing at very long ranges.

#### 6E2. Design aspects of high-performance gun barrels

Ordinary-performance guns have always been made with a high safety margin, but the development of the high-performance barrel, with its concomitant bulk and other complications, required a re-study of gun design, so as to cut safety margin to a minimum. It was with some surprise, during this study, that ordnance engineers learned that the projectile set up higher stresses within the gun than the powder pressure. The liner is obliged to stretch to allow the

projectile to pass through, and to resume its normal diameter after the projectile has passed, rather like an ostrich swallowing an orange. See figure 6E2. Entirely new methods of stress analysis had to be developed to evaluate the influence of this previously unrecognized factor.

#### 6E3. Disadvantages of high-velocity guns.

Reduced time of flight increases a gun's effectiveness, but, especially for shipboard use, there are other considerations. Such guns must necessarily be larger and heavier than conventional guns, so much so that the installation of one high-velocity gun on a present day naval craft might mean sacrificing several guns of ordinary velocity. Moreover, because of the additional powder required, ammunition handling would be complicated and it would be harder to maintain a high rate of fire. Further, these guns wear out more quickly than those designed for ordinary-velocity projectiles. A careful evaluation of all advantages and disadvantages of various types of guns is necessary in determining optimum armament of a ship.

# TURRET INSTALLATIONS

## A. Introduction

### 7A1. General

The type of gun emplacement called a turret is, in general, that in which several heavy guns of at least 6-inch caliber are mounted in an armored structure which is revolved on rollers by suitable machinery, the guns being elevated independently of the structure.

The Bureau of Ordnance designates ordnance equipment as gun mounts or as gun turrets according to the division of cognizance between that bureau and the Bureau of Ships. In general, if the equipment is massive enough to require assembly of parts on the ship as it is being built, it is called a turret. If the assembly is made in a gun shop and then hoisted aboard as a complete unit, it is called a gun mount.

Turret installations on present United States Navy ships are equipped with guns of 6-inch caliber or larger. All turrets have either 2 or 3 guns. They are the primary offensive armament or main battery of cruisers and battleships.

### 7A2. Turret arrangement

Turrets are located fore and aft on the centerline of the ship, so that they are able to fire on either beam. Some turrets are built higher than the adjacent ones, so that they can shoot over them. This arrangement provides the maximum arc of fire, usually about 300 degrees per turret.

### 7A3. Turret armor

All turret structures are protected by armor plate. The gun house is protected by heavy armor plate on the face, sides, roof, and rear. Surrounding the rotating structure below the gun house and extending to the armored decks of the ship, is a fixed cylinder of heavy armor called the barbette. The lower spaces of the turrets are protected by the side armor belt of the ship, and by the armored decks of the ship. All the turret structures, therefore, including the powder

stowage magazines, are completely surrounded by heavy armor protection.

### 7A4. Description of a typical bag-gun turret

All turrets equipped with bag guns are essentially similar. The major portion of this chapter is devoted to a detailed description of the 16-inch 50-caliber 3-gun turret as installed on the *Iowa* class battleships.

Other modern major-caliber turrets such as the 16"/45 caliber, 12"/50 caliber, and 8"/55 caliber (*Baltimore* class) differ from the turret described in many mechanical details, but in general the installations and equipment perform the same basic functions. Therefore, if the operation of one of these assemblies is thoroughly understood it is a relatively simple matter to learn the details of the others from appropriate ordnance publications.

The 16-inch 50-caliber turret has its equipment located on six separate levels. These are (1) the gun house, (2) the pan floor, (3) the machinery floor, (4) and (5) the upper and lower projectile flats and (6) the powder-handling room. See figure 7A1.

The first (upper) level, or *gun house*, contains the turret officer's control booth, the gun compartments, and the right and left sight stations. See figure 7A2. All of these compartments are separated by flame-tight bulkheads. The after part of the gun house contains the only entrance hatch to the turret from the weather deck. The hatch opens into the turret officer's booth. Located in the booth are the range-finder, the local control computer, the fire control and communications circuits necessary for turret control, and the power equipment for the rammer mechanisms. The three separate gun compartments, or gun rooms as they are commonly called, have the controls and equipment necessary for servicing the guns. The two sight stations contain duplicate equipment for the operation of the turret optical sights by the pointers, trainers, and sight setters.

The second level, counting downward, is called the *pan floor*. It contains the pockets or open pits into

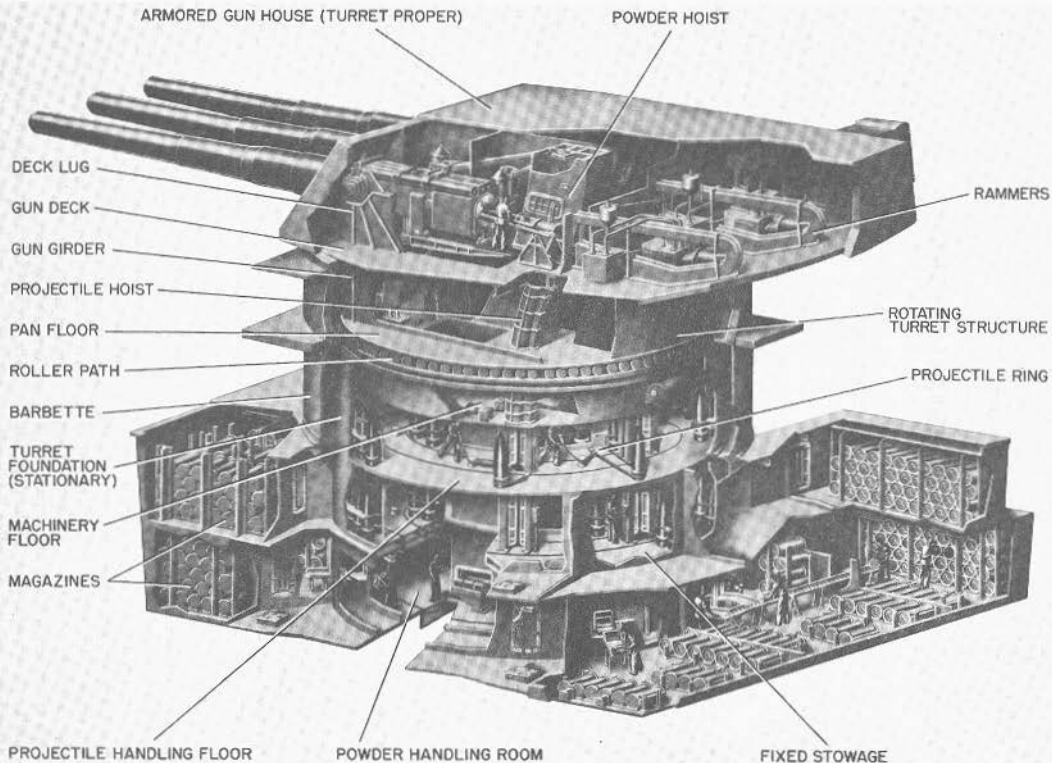

FIGURE 7A1.—Cutaway view of a modern turret (16-inch).

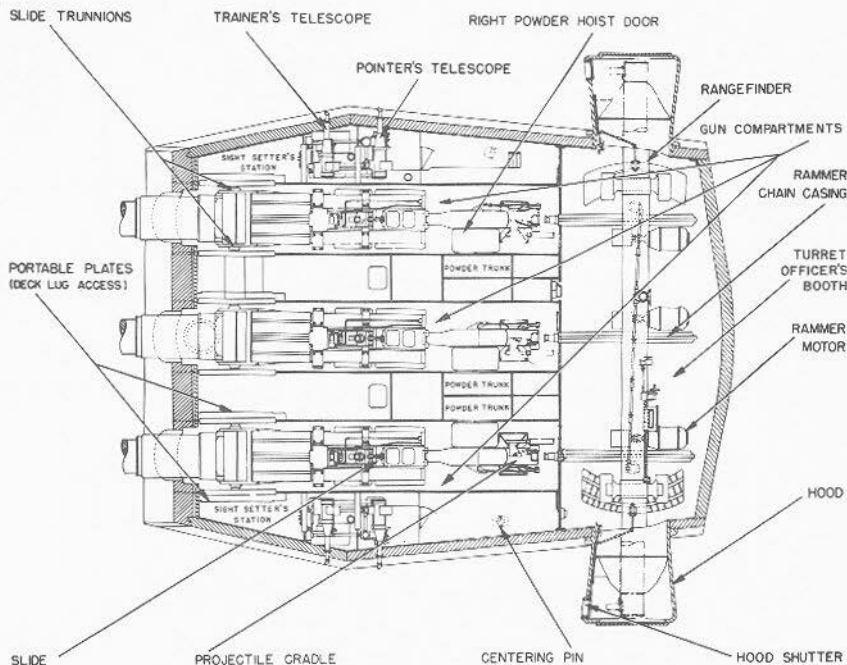

FIGURE 7A2.—Plan view of turret gun house.

which the breeches of the guns are depressed as the guns are elevated. It also contains operating machinery as shown in figure 7A3.

The third level (downward) is the *machinery floor* on which are located the stations for the three gun layers and the turret trainer. They operate the machinery which moves the guns in elevation and the turret in train in response to fire control orders. This level is a maze of electric-hydraulic machinery necessary for turret operation. See figure 7A4.

The next two levels down are the upper and lower

*projectile stowage and handling rooms*, shown in figure 7A5. Here the projectiles are taken from the stowages, loaded into hoists, and lifted up into the gun rooms.

The lowest level is the *powder-handling room*. Surrounding the handling room are the fixed powder-stowage magazines. The bags of powder are passed from the magazines through flameproof openings called powder scuttles into the handling room. Here the bags are loaded into elevator-type hoists which deliver them to the gun rooms.

## B. Gun and Breech Assembly

### 7B1. The gun

The 16"/50 caliber gun is a built-up gun consisting of a liner, a tube, a jacket, three hoops, and a yoke ring. It has an overall length of 68 feet, and a maximum outside diameter of 46 inches at the slide

cylinder. The total weight is approximately 120 tons.

The rifling has a uniform twist of 1 turn in 25 calibers. The bore is chromium plated to retard erosion. The powder chamber is slightly less than 18.5 inches in diameter and about 9 feet long.

The *screw-box liner* is screwed into the breech, and

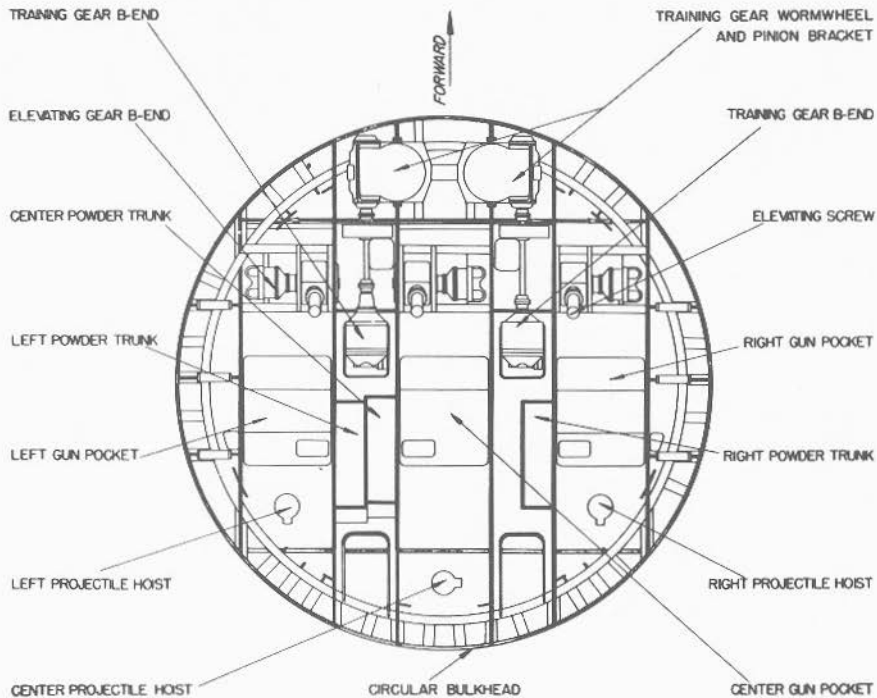

FIGURE 7A3.—Pan floor, plan view, 16"/50 gun turret.

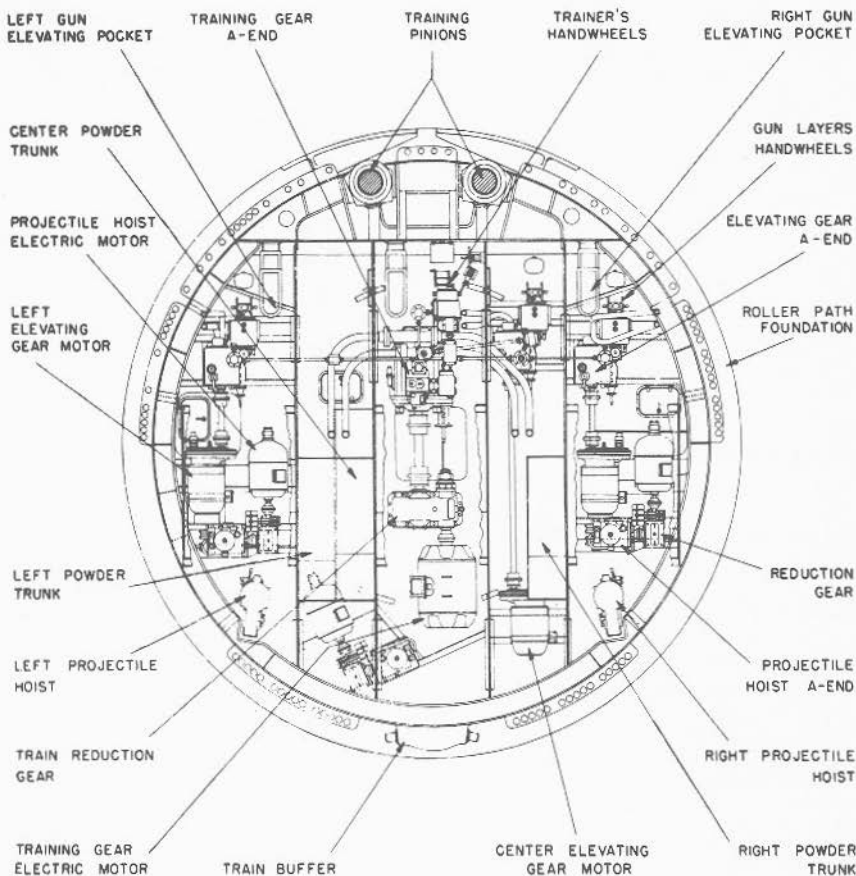

FIGURE 7A4.—Machinery floor, plan view, 16"/50 caliber gun turret.

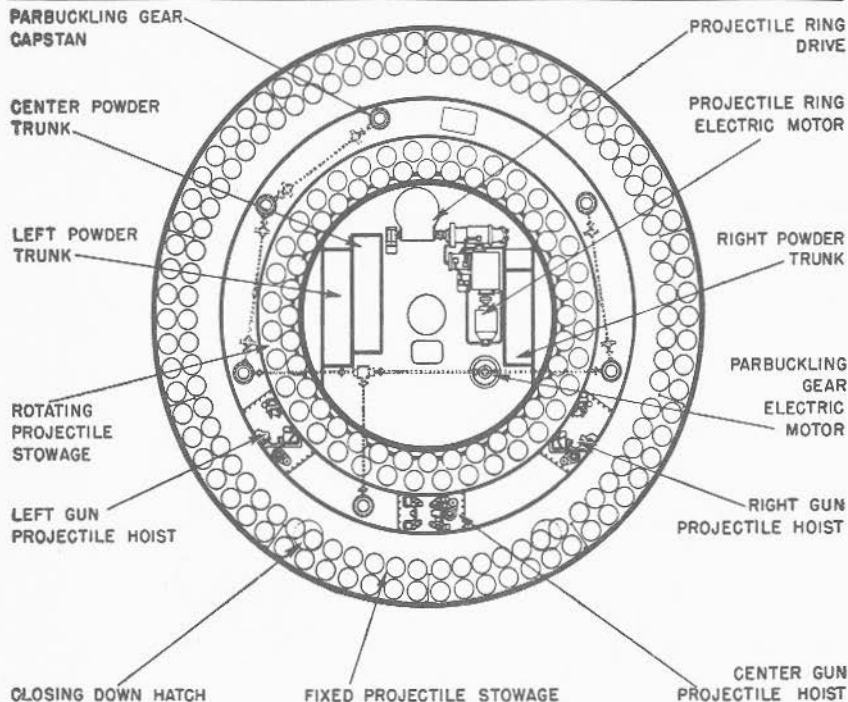

FIGURE 7A5.—Projectile stowage and handling floor, plan view, 16"/50 caliber gun turret.

its inner surface provides the stepped threads which engage those on the Welin-type plug. Ducts between the gun and the liner, and holes through the latter, provide the air leads of the gas-ejector system.

The *yoke* is mounted around the breech end of the gun to provide the means for securing the recoil piston rod and the two counterrecoil cylinder yoke rods to the gun. See figures 7C1 and 7C2. The yoke also helps to counterbalance the gun. The yoke is secured to the gun by a key, a fixed ring, and a locking ring. A shoulder on the yoke butts against the rear face or breech end of the fixed ring secured to the gun in an annular groove. The locking ring screws into the yoke and holds it in place against the fixed ring. The key prevents rotation about the gun axis.

### 7B2. Breech mechanism

The breech mechanism is shown in figures 7B1 and 7B2. Its principal parts include: (1) a Welin-type

plug, (2) a mushroom and gas-check pad, (3) a carrier, (4) counterbalance springs and closing cylinder, (5) rotating cams, (6) an operating lever and connecting rod, and (7) a salvo latch.

*Welin plug and gas seal.* The plug rotates 29° to lock to the screw-box liner. The design of the blank sectors permits the two *plug-rotating cams* to rotate the plug slightly over 6 degrees before the threads engage while the breech is closing. The cam action assists in obtaining a smooth transition between plug translation and rotation.

The *mushroom and gas-check pad* are the conventional De Bange type described in article 5B4. An indication of the mushroom size is that its weight is over 220 pounds.

The plug is mounted on the *carrier* as shown in figure 7B3. The threads on the *carrier journal* and in the plug recess have a pitch of 0.9 inch. This means that the plug will move aft 0.9 inch per counterclockwise

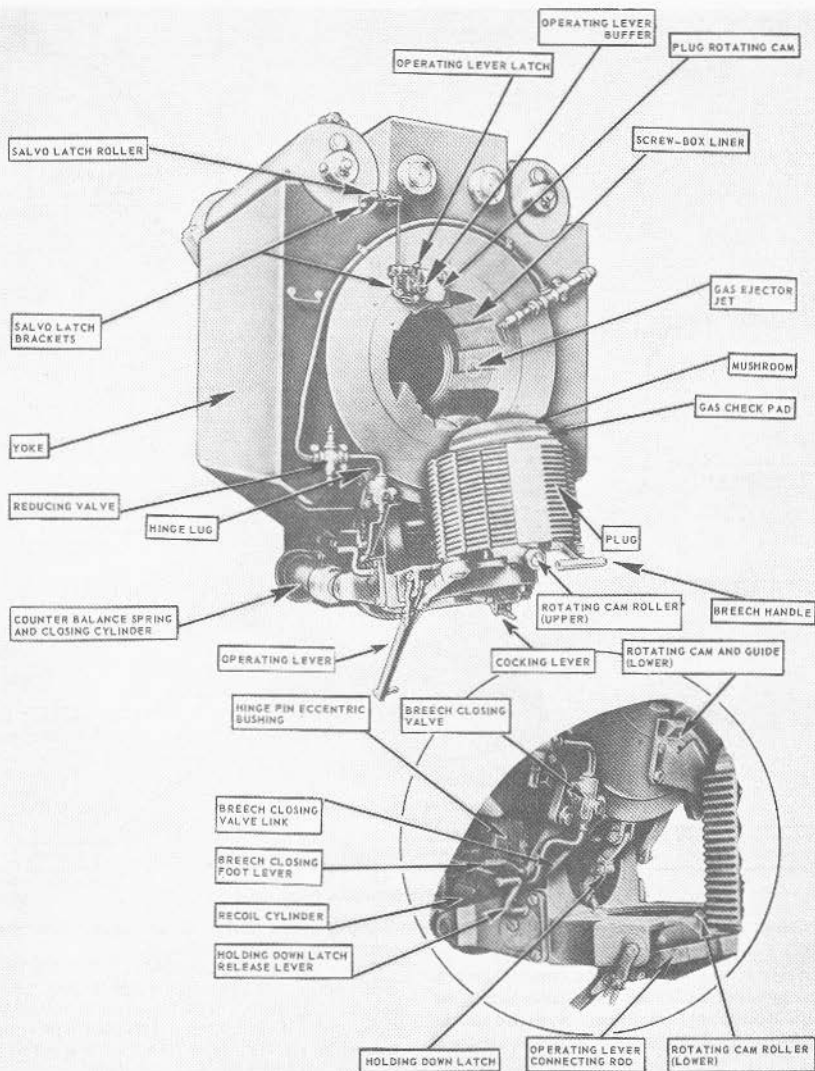

FIGURE 7B1.—16-inch breech mechanism, breech open. Inset: Details of breech operating devices.

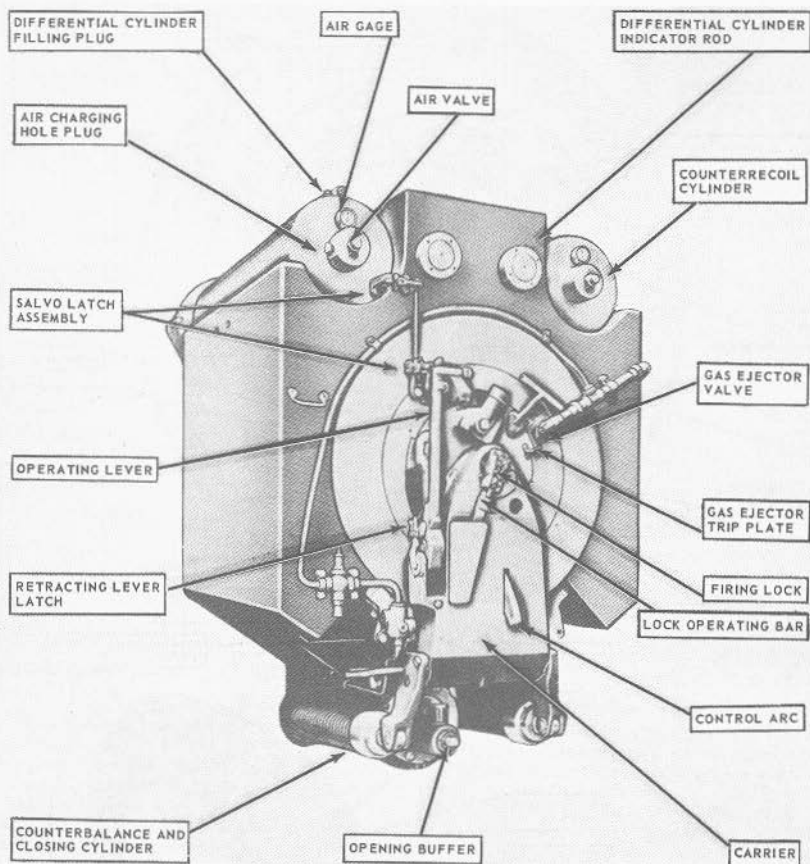

FIGURE 7B2.—16-inch breech mechanism, breech closed.

revolution. Since the plug is unlocked by a rotation of  $29^\circ$ , it is evident that it will move aft on the carrier journal about 0.1 inch when the breech is opened. If the gas-check pad is stuck to the seating surface, the plug will pull away from the back of the pad and the compressed spring around the mushroom stem will tend to force the mushroom nut, and hence the pad, aft. This force ordinarily breaks the seal; but if it

does not, the continued rearward movement of the plug separates the pad from its seat.

*Carrier and associated equipment.* The plug and carrier, which have a combined weight of about 2,000 pounds, swing about a pivot supported by the *hinge lug* secured to the gun. The plug is locked in the open position by a *holding-down latch* until it is released by a foot crank near the loading platform.

The *opening buffer* functions to bring the downward

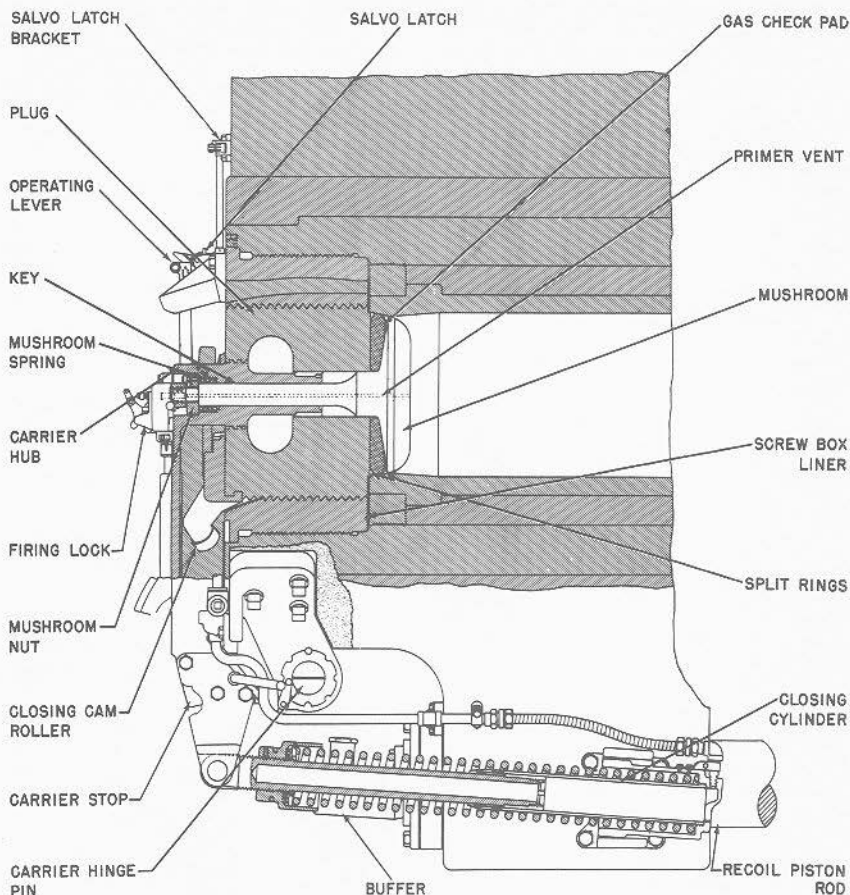

FIGURE 7B3.—Breech plug and carrier.

movement of the carrier to a stop without shock. In construction and operation it is similar to a grooved-wall type of recoil brake. The counterbalance and closing cylinders are a combination of spring and pneumatic mechanisms which function to balance and check the weight of the breech assembly in opening and to furnish assistance in closing the breech. The cylinders receive their air supply from the gas-ejector

system after the pressure has been reduced from 200 to about 40 psi. The counter-balance springs are so adjusted that the breech mechanism will swing down and latch without a jarring stop or rebound. The air pressure in the cylinders is set so that, when the air valve is opened by the gun captain, the breech will close and swing the operating lever nearly home. The swing of the lever is always completed by hand.

*Operating lever and salvo latch.* The operating lever is pivoted on the carrier and is connected to the plug by means of the connecting rod which extends from a pivot on the lever to a pin on the breech-plug rear face. Motion of the operating lever about its fulcrum as it is pulled aft causes the connecting rod to rotate the plug and unlock it from the screw-box liner. A beveled, spring-loaded plunger in the end of the lever engages the *operating-lever latch* when the breech is fully closed. ( See fig. 7B2.) The swing of

the operating lever is stopped by the operating-lever buffer, which is similar to the opening buffer.

The *salvo latch* is an automatic latching device of the positive action type. It functions to prevent lifting of the operating-lever latch when the breech is closed until after the gun has fired. It releases the lever latch as the gun recoils, so that it may be lifted subsequently. Figure 7B4 shows the assembled arrangement.

The *roller support bracket* and *roller* are mounted

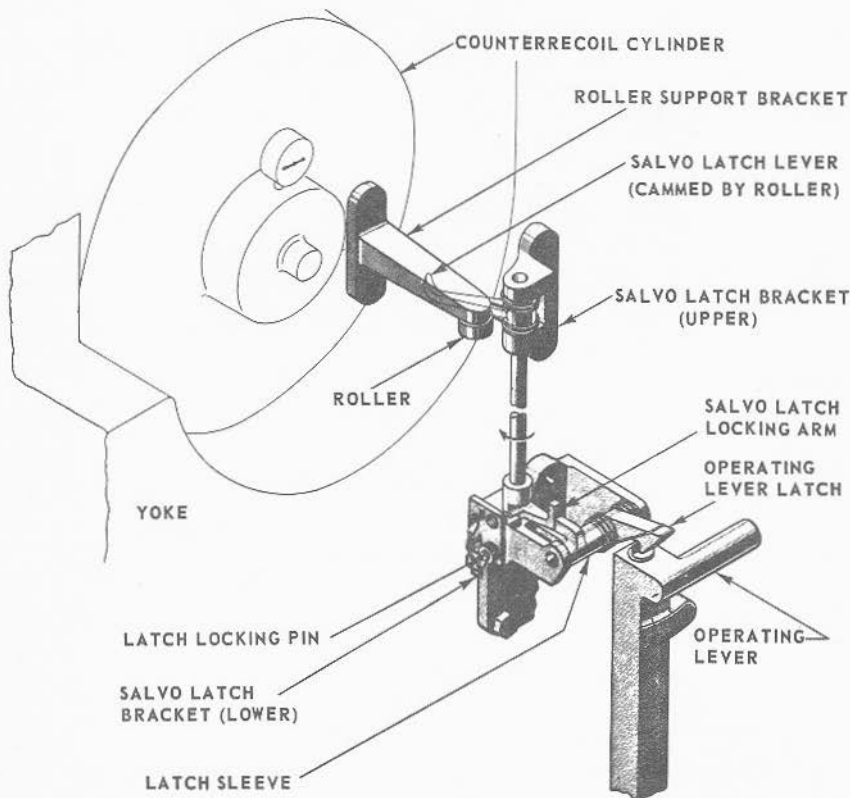

FIGURE 7B4.—Salvo latch for 16-inch gun.

on the counterrecoil cylinder. They are the only parts of the salvo latch assembly which do not recoil. As the gun recoils, the *salvo-latch lever* moves past the roller, and is rotated by it. This turns the shaft and the *salvo-latch locking arm*. The locking arm is caught and held in its displaced position by a *latch catch* (not shown in the figure). This action also holds the salvo-latch lever in its displaced position. The locking arm is thus held out of the way of the lug on the *latch sleeve*. The operating-lever latch, being integral with the latch sleeve, can now be raised against spring pressure to release the breech-operating lever.

After the gun has returned to battery, the plugman opens the breech. His action of raising the operating-lever latch rotates the sleeve and depresses the latch catch, so that the locking arm springs back to its locking position. Then, when the breech is closed, the operating lever slides under the operating-lever latch, where it is caught and held.

For drills the salvo latch is secured in its unlocked position, so that the habit of manually unlocking the salvo latch will not be formed. This is accomplished by screwing the latch locking pin in hole B. The pin holds the salvo-latch locking arm in its displaced position. At all other times, it must be kept in the turret officer's booth.

### 7B3. Firing mechanism

The firing mechanism consists of a Mark 14 Mod 5 *firing lock* and the associated operating devices which synchronize its action with that of the operating lever. The firing lock, shown in figure 7B5, consists of a *receiver* which is attached to the end of the mushroom stem and a *wedge* which slides back and forth in the receiver, to open and close the primer chamber in the mushroom stem. The *primer-retaining catch* helps to hold the primer in place until the wedge closes; the *extractor* ejects the primer case as the wedge opens. The wedge contains an insulated firing pin which carries the current to the primer bridge for electrical firing. For percussion firing, a hammer, a contact piece, and a cocking lever attached to the wedge function to deliver a blow to the firing pin. This is accomplished by drawing back the cocking lever, which pulls the hammer with it until a catch on the lever releases the hammer. As the hammer is drawn back, the hammer spring is compressed. When the hammer is released, this spring drives the hammer forward, making the contact piece strike the firing pin, which transmits the blow to the primer.

Safety features incorporated in the lock prevent

firing until the gun breech and the firing lock are completely closed. These include:

1. A lug on the hammer slides in a groove in the receiver and lifts the hammer enough to break electrical contact between the firing pin and primer until the wedge is in the closed position.
2. The same lug also prevents the hammer from being drawn back for percussion firing until the wedge is in the closed position.
3. The hammer thrust pin must line up with a hole in the carrier before the cocking lever can be pulled back for percussion firing. This alignment occurs only when the wedge is fully closed.
4. The cocking lever is so constructed that it transmits any accidental blow directly to the wedge instead of to the hammer and firing pin. The hammer placed between the cocking lever and the wedge is amply protected from exterior blows.

The wedge is connected with the breech-plug operating lever by means of a *lock-operating bar* (fig. 7B2) and a mechanical linkage. The motion is such that the wedge is withdrawn and the primer extracted when the operating lever is pulled aft and down in opening the breech. To reprime in case of a misfire the wedge can be retracted, without opening the breech, by unlatching the retracting lever latch (fig. 7B2) and rotating the retracting lever. This permits downward movement of the lock operating bar without moving the breech operating lever. But the wedge cannot be fully closed unless the breech is closed and locked.

The wedge is secured to the operating bar by means of a pin. The hole in the wedge through which the pin passes is slotted to permit movement of the mushroom stem during fire. The firing lock can be removed by taking out the pin and turning the receiver 90 degrees to unfasten it from the mushroom stem.

### 7B4. Gas-ejector system

The system includes a series of storage tanks, piping with the necessary swivel and expansion joints, the gas-ejector valve (fig. 7B2), the gas-ejector trip plate, passages through the screw-box liner, and nozzles which direct the air into the bore. Air at 150 to 200 psi from the ship's compressors is brought into the turret through the central column for the main gas ejectors, the auxiliary gas ejectors, and the pneumatic breech-closing cylinders.

From the tank the air is piped to the slide and thence through an expansion joint to the breech. The gas-ejector valve controls the flow of air in the

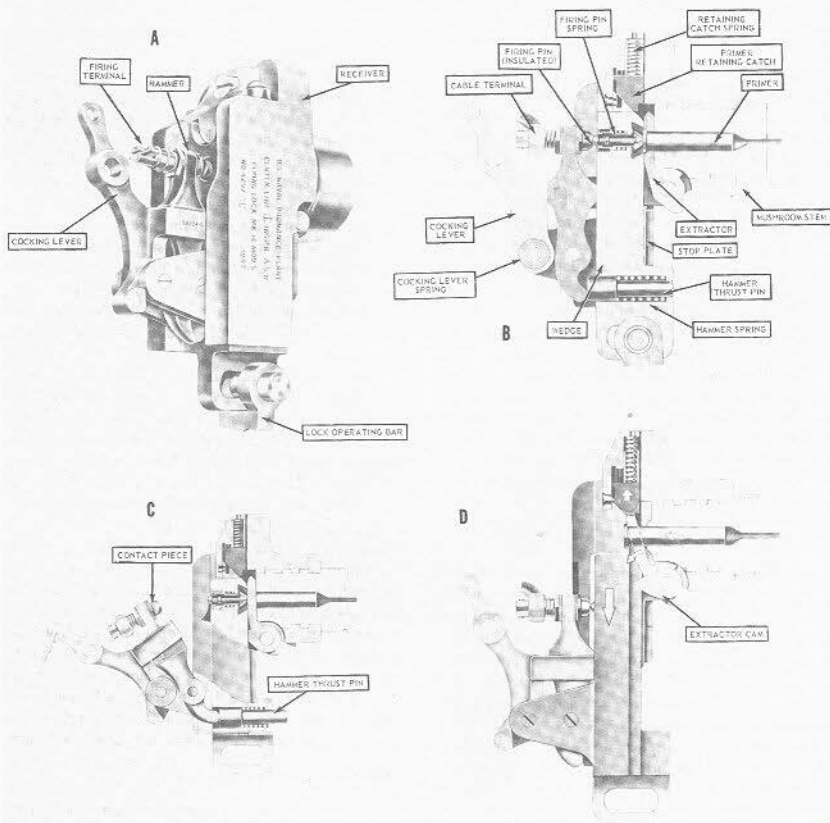

FIGURE 7B5.—Mark 14 firing lock.

A: Assembled view, wedge closed.

C: Percussion firing position.

B: Electrical firing position.

D: Ejecting primer after firing.

ejector system. It is automatically opened by the gas-ejector trip plate when the plug is turned for opening the breech, and is closed manually when the bore is clear. When the valve is opened, air is admitted to an annular space between the screw-box liner and the gun. Three equally spaced holes extend through the liner from this space, and nozzles are recessed into

their ends. The air jets direct their streams forward toward the bore center.

An auxiliary gas ejector consisting of a hose with a quick-acting valve and nozzle is stowed overhead near the breech. This is a standby device which can be directed into the gun to clear the bore in case normal gas ejection by the primary means fails.

### C. Slide Assembly

#### 7C1. General

Although in general the principles of gun mount construction as discussed in chapter 5 apply to the gun, slide, and deck lug structures of bag-type turret guns, there are important differences in some details, particularly with respect to the relationship of recoiling and nonrecoiling parts, and the locations of components of the recoil and counterrecoil systems. Therefore, in addition to figure 7C2, which shows in an exterior view the gun and slide of a 16-inch turret gun, figure 7C1 shows, in simplified exploded schematic form, the relationship of recoiling and nonrecoiling parts, and the locations of important parts of the recoil and counterrecoil systems.

Each gun has a separate slide which is individually mounted in trunnion bearings and is arranged for independent elevating movement. The main element is a steel forging, shown in figure 7C2, with attached parts which include: (1) the trunnions, (2) the rear end brackets, (3) the loaders' platform bracket, (4) the hydraulic recoil system, (5) the counterrecoil recuperator system, (6) the slide-securing device, (7) the yoke-locking device, (8) upper and lower shield plates, and (9) a cylindrical gun cover. The complete assembly is over 33.5 feet long, 79 inches across the trunnions and 116.5 inches high. The total weight

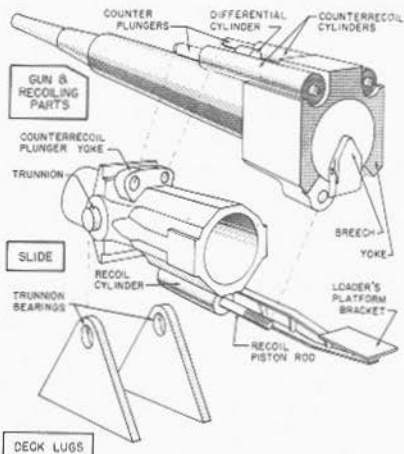

FIGURE 7C1.—16-inch gun assembly. Simplified exploded schematic.

is 51.5 tons. All 3 guns in the turret are identical, except that a few components, found on 1 side of the right and center guns, are on the opposite side of the left gun. Figure 7C2 shows a left gun.

The gun-slide bore of the steel forging is fitted with 6 bronze liners, each 10 inches wide. The liners are provided with oil grooves and are the bearing surfaces on which the gun slides during recoil and counter-recoil.

#### 7C3. The trunnions

Integral with the slide are the 18.5-inch diameter trunnion journals. Each of these journals rests in a specially designed roller-bearing assembly fitted into a deck lug (fig. 7A1) which is supported by the gun girder. Each bearing includes 24 cylinder rollers 2.5 inches in diameter and 3.5 inches long. These bearings carry the weight of the entire gun and take the shock of firing.

#### 7C4. The rear end brackets

These brackets are bolted to the left and right side of the slide. One rear end bracket, as shown in figure 7C2, provides mounting attachments for the loaders' platform bracket and the slide-securing pin is seated in an aligned socket in an adjacent gun girder when the gun is at zero degrees elevation. The pin is forced into the socket by means of a handwheel-operated screw. This arrangement serves to relieve the elevating screw and drive gear from the effects of roll, pitch, and vibration when the gun is not being used. Another socket permits locking the gun at 20° elevation while the recuperator air cylinders are being charged. The other rear bracket on the slide (not shown in fig. 7C2) mounts the large pivot pin to which the elevating screw is attached. (See article 7D1.)

#### 7C5. Recoil mechanism

The recoil mechanism is the conventional hydraulic type and has a single cylinder of 26-inch bore diameter and an over-all length of about 5 feet. It is similar to the one shown in chapter 5. Three equally spaced throttling rods control recoil fluid flow. The recoil, limited to 48 inches (3 calibers), occurs in approximately one-third second.

Counterrecoil buffing action is provided by a plunger-dashpot arrangement at the forward end of the cylinder. Liquid displacement from the dashpot occurs through four grooves of variable depth and through the small clearance between the plunger and the dashpot entrance. Buffing action takes place

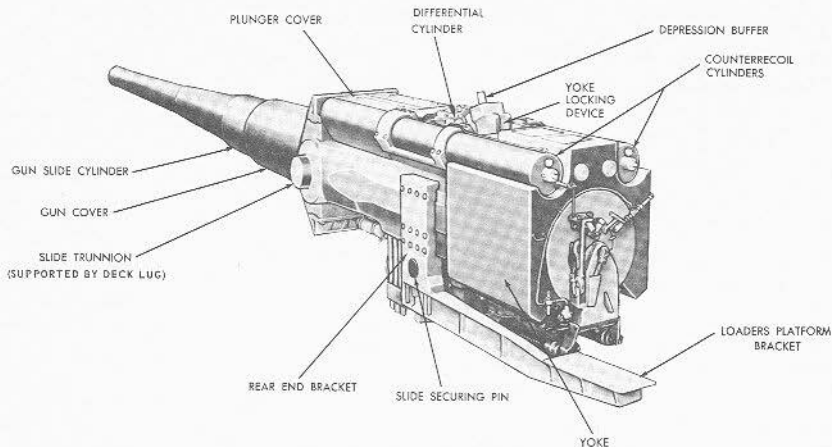

FIGURE 7C2.—16-inch gun assembly, side view (left gun).

during the last 16 inches of counterrecoil. Two expansion tanks are mounted forward of the recoil cylinders.

#### 7C6. Recuperator

The hydropneumatic counterrecoil mechanism consists of two air cylinders mounted on top of the slide and a differential cylinder between them. Its operating principles are discussed in chapter 5. The counterrecoil cylinders, shown in figure 7C2, are about 11 feet long and have an inside diameter of 14 inches. The plungers are hollow cylinders closed at the forward end, and are about 6 feet long and 11 inches in outside diameter. They are connected to the gun yoke by means of a plunger yoke and two yoke rods which are covered by the plunger cover (fig. 7C2).

#### 7C7. Yoke-locking device

This device, which holds the gun in battery when it is not in use, even though pressure in the recuperator is lost, is on top of the slide, at the rear, between the counterrecoil cylinders. A safety link, in the form of an eyebolt, is pinned to the slide. When locked, the

safety link rests in a notched bracket on top of the yoke, and a nut on the link is tight against the bracket, holding the yoke and gun securely to the slide. The link is stowed by loosening the nut, swinging the pin up and forward, and clamping it out of the way. If the link is inadvertently left in place when the gun is fired, it will part without damage to the gun, but it must be replaced without delay.

#### 7C8. The shield plates and gun cover

The upper and lower shield plates are located just inside the gun port at the face plate of the turret. They form a weather and splinter shield for the slide. The gun cover is a  $\frac{1}{2}$ -inch thick cylinder whose inside diameter is slightly larger than the gun's slide cylinder. It extends through the gun port about seven feet. At its forward end there is a wiping-ring assembly which serves as an oil and weather seal for the gun. A neoprene cover (gun buckler) clamps on the outer end of the gun cover and is attached on the sloping front face of the armor plate, completely enclosing the gun port.

## D. Elevating, Training, and Sight Gear

#### 7D1. Elevating gear

The three elevating-gear installations of each turret are independent assemblies. Each assembly consists of an electric-hydraulic power drive, an oscillating

bearing assembly, and control mechanisms, shown schematically in figure 7D1. The greater part of these assemblies are located below the respective guns, forward and below the gun pockets in the pan and

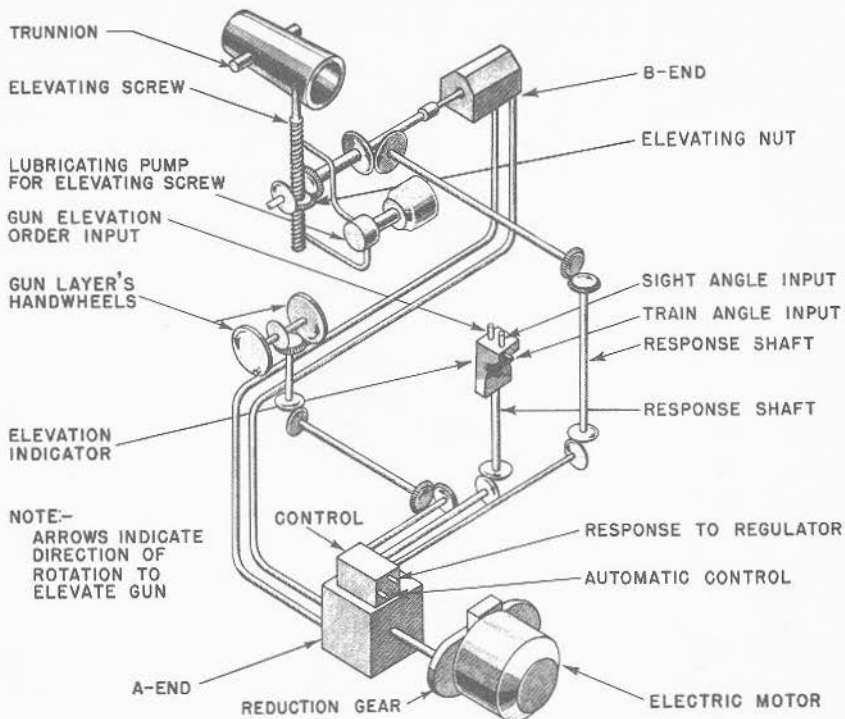

FIGURE 7D1.—Elevating gear for 16-inch gun.

machinery floor spaces. The arrangements on these levels are shown in figures 7A3 and 7A4.

The electric-hydraulic power drive has a 60-horsepower electric motor driving a variable-displacement hydraulic pump (A-end) which supplies oil pressure to a fixed-displacement hydraulic motor (B-end), as described more completely in chapter 10. The B-end output shaft is connected to the elevating-nut drive. (See fig. 7D1.) The elevating nut is threaded around the elevating screw and is mounted in the oscillating bearing (not shown in fig. 7D1), which allows the complete assembly to tilt. The elevating screw is secured to the pivot pin on the rear end bracket of the gun slide, and is moved up or down as the elevating nut rotates.

Gun-elevating movement is controlled automatically by means of a receiver-regulator or by rotation of the gun layer's handwheels on the machinery floor. In the latter method the gun-laying personnel (one gun layer for each gun) control the power drive in accordance with dial-indicated gun-elevation orders emanating from either the director system or one of the two sighting stations within the turret. Elevation stops are installed to limit elevation and depression to  $45^\circ$  and minus  $2^\circ$ , respectively. The maximum elevating speed is approximately  $12^\circ$  of arc per second. After firing the gun is automatically lowered to the loading angle of five degrees elevation by operation of a control lever.

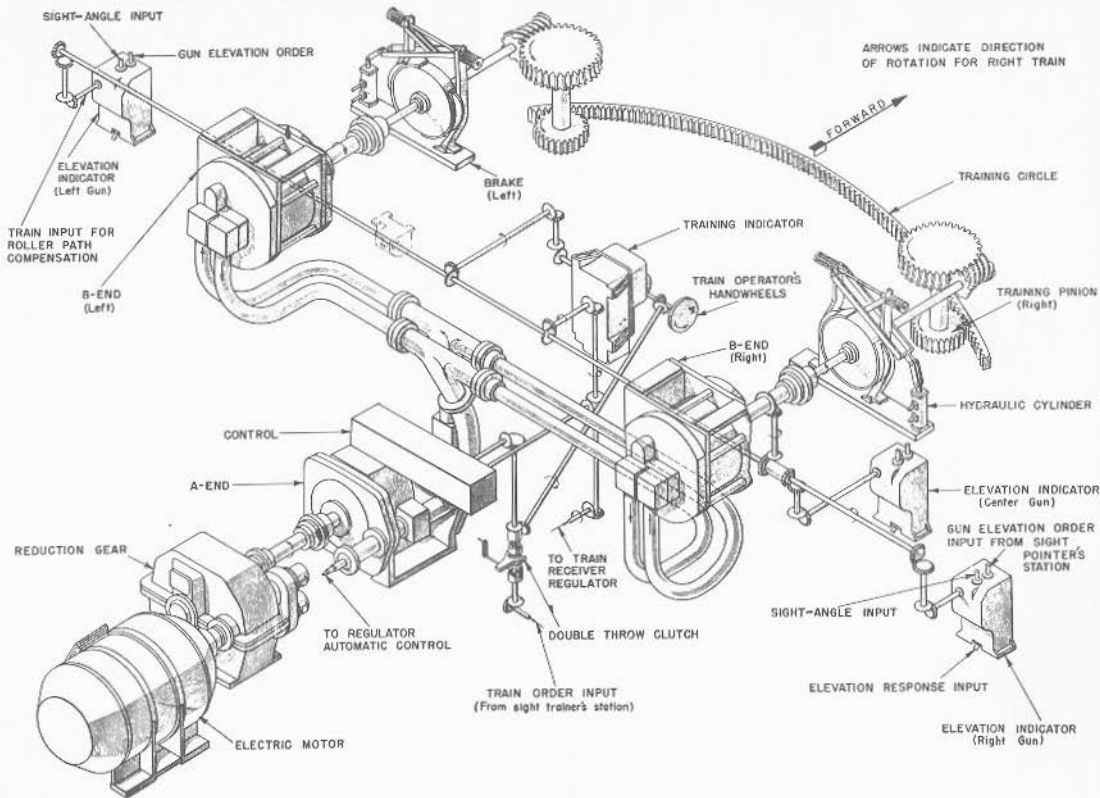

FIGURE 7D2.—Training gear for 16-inch gun.

**7D2. Training gear**

The training gear and its control equipment, shown schematically in figure 7D2, also consists of an electric-hydraulic power drive which can be automatically or manually controlled. The electric motor (300 hp, with an overload rating of 540 hp) drives the A-end of the hydraulic transmission unit through a reduction gear. Two B-end units are driven by the single A-end.

The B-ends drive the training pinions, which mesh with the training circle secured to the turret foundation. The brakes between the B-ends and the pinions function to prevent the turret from turning when the training power is off. The brakes are set by springs and released by hydraulic cylinders. When power is off, no pressure is in the hydraulic cylinders, and the springs set the brakes. During training, a piston in each cylinder is forced upward by oil under pressure, releasing the brakes.

Training may be automatically controlled from the director system through a receiver-regulator, or locally controlled from either the gun deck or the machinery floor by handwheels. In indicator gun laying, either the train operator on the machinery floor trains the turret in accordance with dial-indicated train-order signals, received from the director system or turret sighting stations, or one of the sight trainers controls the drive by keeping his telescope on the target.

**7D3. Sighting gear**

Each 16-inch turret has duplicate sight stations in enclosed compartments located outboard from the wing guns and approximately on the transverse centerline of the turret. Each station transmits gun elevation or gun train orders to the indicators and control gear on the machinery floor from which the power is actually applied to the turret and guns. The pointer's and the trainer's telescopes are so mounted that they have parallel motions when the sight settings are made.

Corresponding elements of the two stations are interconnected so that either station can take over sighting operations. When this is done, the guns are indirectly positioned from a sight station by first setting the sight. The pointer and trainer then turn their handwheels to keep the crosslines of the telescopes on the target. The pointer's handwheel operates indicators at the gun layer's station. By keeping a dial pointer matched with these indications, the gun layer positions the gun in elevation. The trainer's handwheel can accomplish the same result in train. In addition, it is possible, by use of appropriate selector, for the trainer in the gun house to bypass the trainer at the machinery level and move the turret directly in train, as he rotates his handwheel in keeping his vertical crosslines on the target.

**E. Ammunition Handling****7E1. Projectile stowage**

Projectile stowage in each turret is arranged in two circular compartments, called upper and lower projectile flats. Figures 7A5 and 7E1 show the arrangement of these flats. The projectile stowage spaces are between the turret foundation bulkhead and an inner concentric circular bulkhead. The latter bulkhead surrounds machinery compartments at the center of each flat and separates them from the stowage and handling compartment. In each stowage compartment the floor is subdivided into three concentric ring-shaped platforms. The outer ring is a fixed shelf attached to the turret foundation and provides the "fixed" projectile stowage. The intermediate ring is part of the rotating structure and is the shell-handling platform. The three projectile hoists have loading apertures in this intermediate ring. The inner ring is a roller-mounted platform supported by the turret rotating structure and has a power drive which can rotate the ring in either direction with respect to the intermediate ring. This inner ring provides the "rotating" projectile stowage.

Projectiles are brought to these stowages as follows:

first, they land on the main deck in a horizontal position and a shell carrier (on the left in fig. 7E2) is fitted around them. An electric drum-type hoist then lowers them in vertical position (center item in fig. 7E2) through hatches alongside the turret to the second platform level. Here they are transferred to an overhead trolley, from which they hang in horizontal position (on the right in fig. 7E2). The trolley takes them under a hatch in the projectile flat, where they are transferred to an electric whip hoist which hauls them (in vertical position) up to the projectile flat to be stowed. The projectiles are lowered and hoisted one at a time; when each projectile reaches the flat, its carrier is removed and sent up to the main deck to be used again. The projectiles are stowed standing on their bases, and each is separately lashed to the bulkhead.

With the projectile rings loaded and ready for use, the inner rotating projectile ring moves projectiles to positions near the hoists. All 3 hoists can be served simultaneously from 1 ring. Loading into the hoists is performed by parbuckling—passing a line around the projectile, leading the line to a power-operated capstan, and sliding the projectile along on its base.

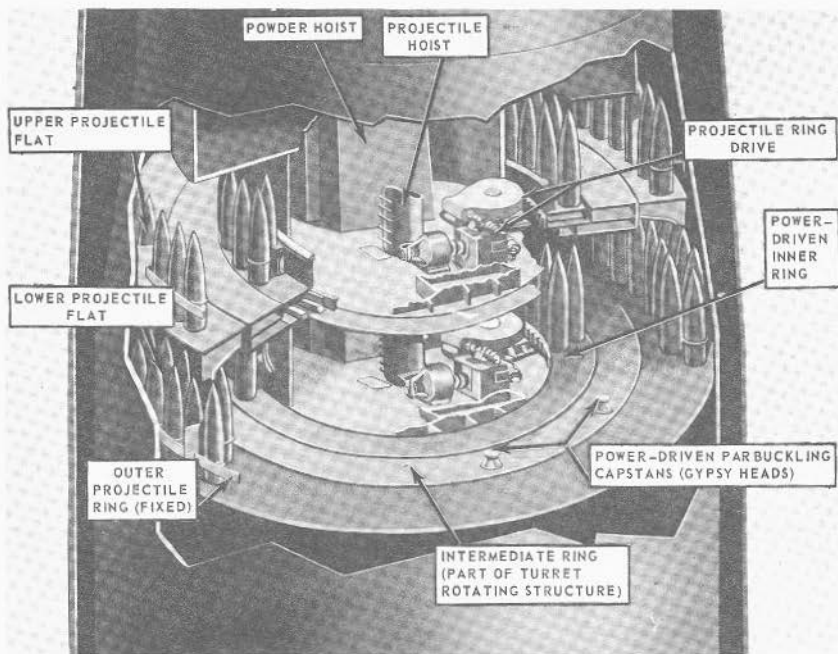

FIGURE 7E1.—Projectile flats in 16-inch turret.

See figures 7A5 and 7E1. The parbuckling gear can also deliver the projectiles from fixed stowages to the rotating ring. Manual controls with automatic stop arrangements operate the rotating ring through arcs of 30 degrees to facilitate continuous delivery to the hoists. Three projectiles per minute per hoist can be delivered.

### 7E2. Projectile hoist

Each gun has a projectile hoist which raises the projectiles from the stowage compartments in the turret rotating structure to the breech end of the gun. The hoist (see fig. 7E3) consists of a tube through which the projectile passes (base downward), a hydraulic-ram-type lift, and a power drive with its associated control. The three tubes pass through the middle rings of the projectile flats and are almost vertical up to the pan floor. From this point the two outboard tubes slope rearward at an angle to the cradles at the upper ends of the tubes. The

center tube continues its vertical course, so that at the guns all cradles are equidistant from the breech.

The hydraulic lift consists of a hydraulic cylinder vertically mounted between the decks of the projectile flats, a piston, and a piston rod which connects to a rack in the tube casing. The piston diameter is about 6 inches, and the piston stroke is approximately 8 feet. The hydraulic lift raises or lowers the projectiles one stage per stroke. The distance to the cradle is 4 stages from the lower projectile flat and 3 from the upper.

The hoist contains 2 sets of spring-loaded pawls, 1 set on the rack connected to the hydraulic piston, and the other on the inner wall of the hoist tube. The pawls in each set are spaced one stage apart. The principles of operation of pawl-type hoists were explained in chapter 5. As the piston and rack move up, the lowest rack pawl picks up the projectile base and pushes it upward past the tube pawl at the next stage. Then the rack moves downward with the

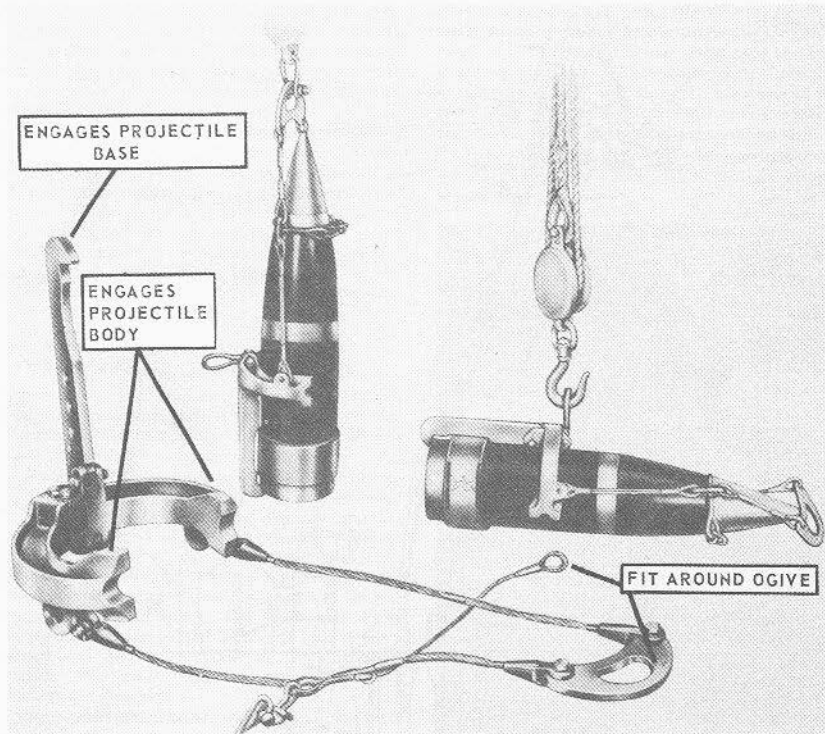

FIGURE 7E2.—Shell carrier for 16-inch projectiles. *Left:* The carrier. *Center:* Carrying projectile in vertical position. *Right:* Carrying projectile in horizontal position.

piston down stroke, but the tube pawl engages and supports the projectile's base. The projectile body forces the rack pawl for the next stage to retract as the rack descends. At the end of the stroke, this pawl is under the projectile, ready to lift it when the rack moves up again. The process repeats until the projectile is at the top of the hoist.

The pawls can be hydraulically retracted as required, so that the hoist can also be used for lowering.

The power drive for each hoist is located on the machinery floor and consists of an electric motor (75 hp), a reduction gear, and the A-end of a hydraulic speed gear. The A-end is directly connected to the hoist cylinder and develops the 700 psi pressure required to lift a full load of 4 projectiles. A solenoid

brake on the electric-motor shaft operates to prevent motion of the hoist when there is a power failure.

The main hoist-control system includes duplicate installations of control handles at stations near the hoist-loading apertures in the upper and lower projectile flats, mechanical and electrical interlocks, and audible and visual signals at these stations.

Mechanical and electrical interlocks prevent operation of control handles when projectiles are being loaded in the hoist, when there is a projectile in the cradle, or during the ramming cycle.

### 7E3. Cradle

The cradle assembly shown in figures 7E3, 7E5, and 7E6 includes the *cradle fulcrum*, *cradle*, and *spanning*

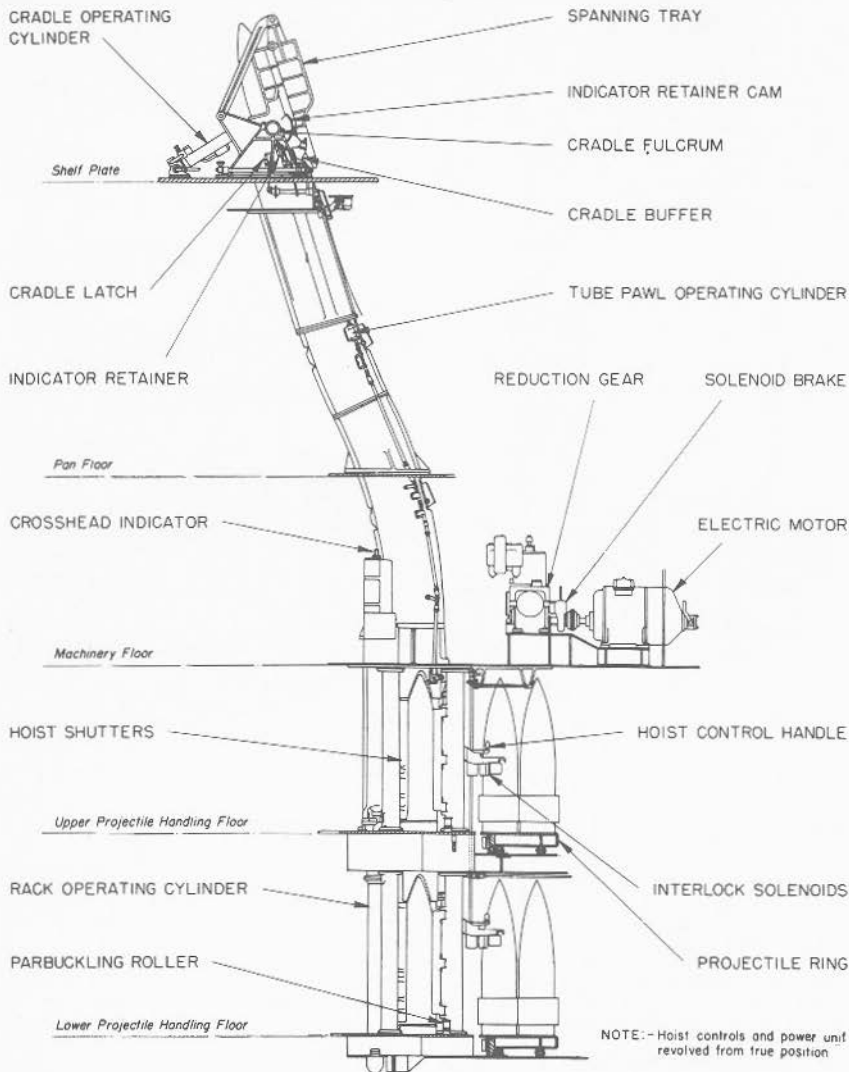

FIGURE 7E3.—16-inch projectile hoist.

tray. During hoisting the rammer chain is in its retracted position, the cradle is upright so that its axis lines up with that of the hoist tube, and the spanning tray is folded against the cradle. A projectile hoisted into the cradle is supported there by a projectile latch within.

The cradle and spanning tray are operated by a hydraulic cylinder not shown in the figures. The control lever for this unit is located at the after end of the gun compartment at the side of the rammer and cradle. When the control lever is operated, the cradle tips forward and the spanning tray moves forward and down, forming a smooth path from the hoist to the chamber. (Fig. 7E5.) The gun must be elevated to 5 degrees for loading, so that the tray lines up with the gun bore.

#### 7E4. Rammer

The rammer consists essentially of a special roller-type chain which meshes with a power-driven sprocket. The arrangement of parts is shown in figure 7E6. The rammer assembly is located in the turret officer's booth just abaft the gun compartment.

The power drive includes an electric motor (60 hp with an overload rating of 108 hp) and a conventional hydraulic speed gear whose B-end drives the sprocket wheel. The control arrangement provides full-power projectile ramming to a jammed stop. This is necessary, since the rotating band must be forced into the rifling so that the projectile will not move to the rear when the gun is elevated. The maximum velocity during the ramming cycle is slightly less than 14 feet a second, and the time required for ramming is 1.7 seconds. The powder bags are rammed into the chamber at a slower speed.

The rammer chain forms a rigid column when it is extended. The chain assembly, including the head link buffer, is about 25 feet long. When in the "ready to ram" position the ramming head is about 8 inches behind the projectile base and 9 feet from the breech face. The projectile travel to full seat during ramming is about 19 feet.

#### 7E5. Powder hoist

The powder magazines are outside the turret foundation on the platform deck beneath the lower projectile flat. The powder is passed manually through self-closing scuttles in the powder-handling room bulkheads and in the lower foundation, into the hoist-loading space around the lower end of the turret revolving structure, and delivered by hoists to the guns.

An electric-hydraulic powered hoist is provided for each gun. Each hoist contains a powder car (fig. 7E4) which rides up and down like an elevator in a

closed, inclined trunk which extends through the turret structure from the hoist-loading space to the turret roof. The car is a large box-shaped structure closed on three sides. Four guide wheels, mounted on the rear corners, ride along the after side of the trunk. The bags are carried on two vertically spaced trays which can be separately tilted by means of hand levers on one side of the car. A loaded car delivers a full-service charge of six bags to the gun without intermediate handling.

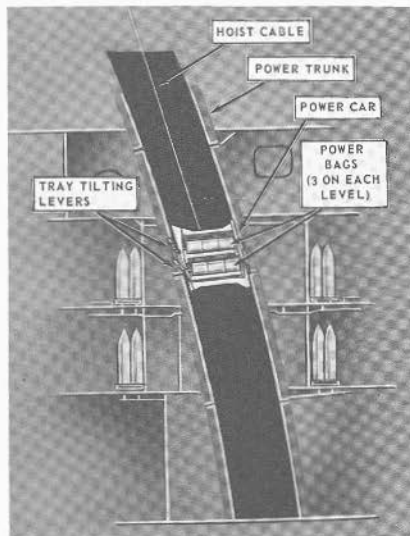

FIGURE 7E4.—Powder car and trunk for 16-inch turret.

The car is loaded in the hoist-loading space beneath the projectile flats, through an aperture in the trunk. This opening is sealed by a manually operated, vertically sliding door which must be closed before the car can be hoisted or lowered. It cannot be opened unless the car is in its loading position.

Powder is delivered to the gun through a door located just abaft and to one side of the breech mechanism. The door swings outward and down, providing a shelf across which the powder bags roll from the car to the loading tray. (Fig. 7E5.) The door is operated by a hydraulic power device. When the delivery door is open, the car can be lowered, but not raised. The interlocking features make it im-

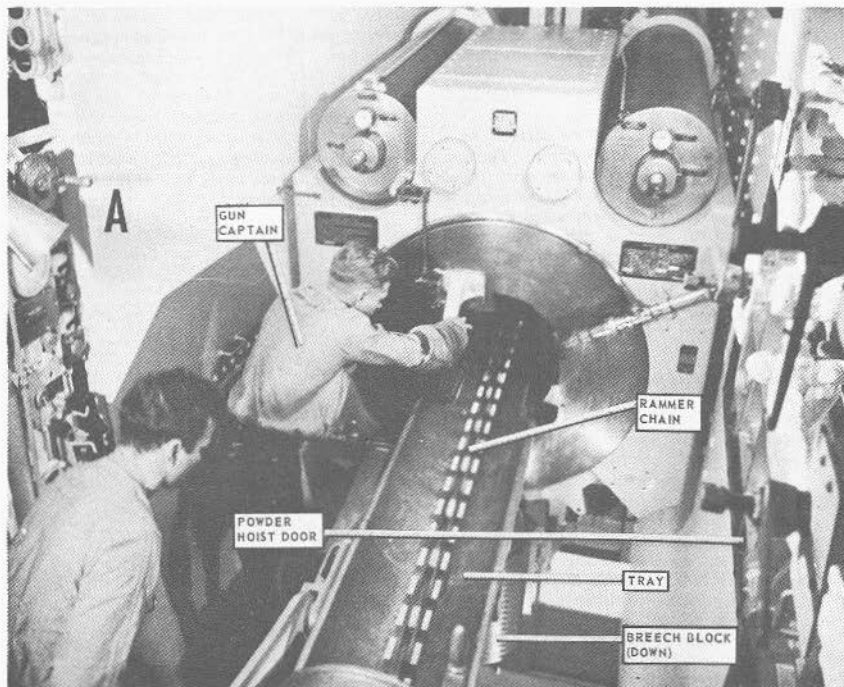

FIGURE 7E5.—Loading a round of ammunition into a 16-inch gun. A. Ramming the projectile.

possible to have both the loading and the delivery doors open at the same time.

The hoist power unit consists of an electric motor (100 hp) and a conventional hydraulic speed gear that drives a hoisting drum. This unit is located in the gun compartment next to the trunk. The car is lowered by gravity and hoisted by means of a  $\frac{3}{8}$ -inch diameter wire rope which passes over a sheave under the turret top plate and thence to the hoisting drum.

The hoist control is located at the hoist operator's station near the top of and abaft the trunk. Control arrangements include visual powder hoist indicators, starting and control selector levers, devices which limit acceleration and deceleration rates, door interlock switches, safety car-stop operating devices, and a power-failure brake on the hoist drum. The latter prevents the car from falling in case of power failure or rupture of hydraulic leads.

#### 7E6. Loading operation

A 16-inch 3-gun turret can be operated with a minimum crew of 77 men inside the turret. Station assignments for the turret crew are ordinarily as listed in the accompanying table.

#### STATION ASSIGNMENTS, TURRET CREW

Station	Location
Turret officer.....	Rangefinder and Turret Officer's compartment.
Turret officer's talker.....	
Turret captain.....	
Computer operators (2)....	
Rangefinder operator.....	
Rangefinder pointer.....	
Rangefinder trainer.....	
Talker.....	

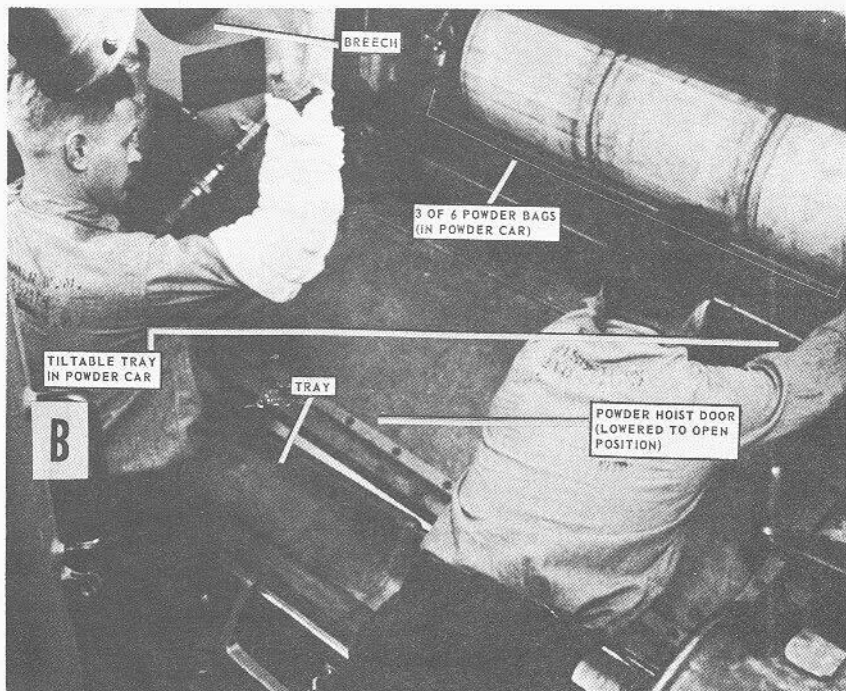

FIGURE 7E5.—(Continued.) B. Powder hoist door open, rammer withdrawn.

## STATION ASSIGNMENTS, TURRET CREW (Con.)

Station	Location
Sight trainer, right.....	Right sight station.
Sight pointer, right.....	
Sight setter, right.....	
Sight trainer, left.....	Left sight station.
Sight pointer, left.....	
Sight setter, left.....	
Plugmen (gun captains) (3)	Gun rooms.
Cradle operators (3).....	
Rammer operators (3).....	
Primermen (3).....	
Powder-hoist operators (3).....	Top, powder trunks.
Gun layers (3).....	Machinery floor.
Gun train operator.....	

Station	Location
Projectile-hoist operators (3)	Projectile-handling floor (each level).
Projectile-ring operator.....	
Shellmen (9).....	
Electrician.....	
Shell-deck P. O.....	
Powder-door operators (3).....	Powder-handling floor.
Powder passers (9).....	
Handling-room P. O.....	

In addition, there are 6 powder passers in the annular space between the powder-handling room and the magazines, and 12 powder passers in the magazines.

With the turret in all respects ready to fire and the power machinery in operation, the first command is:

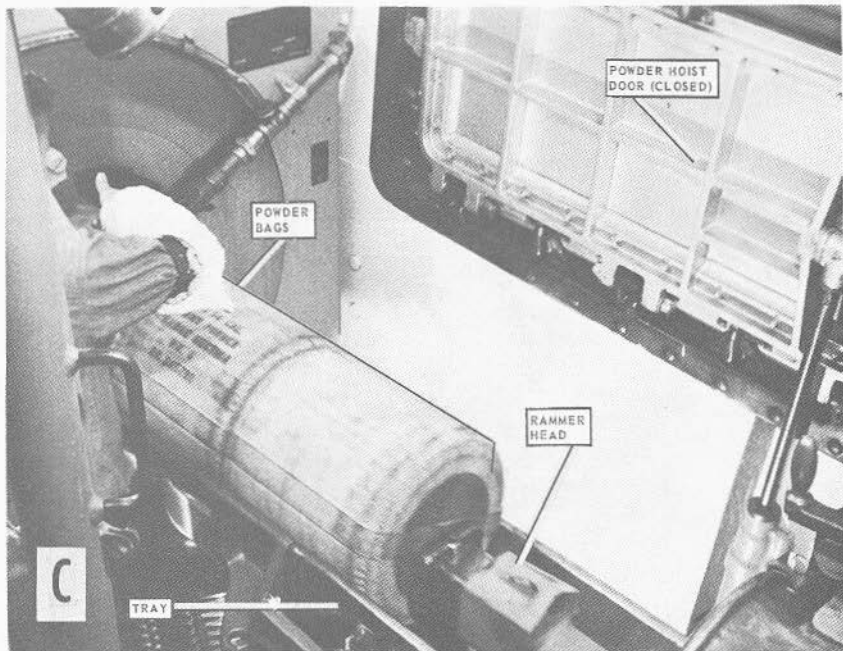

FIGURE 7E5.—(Continued.) C. Loading the powder.

"Fill the powder train; fill the projectile hoists." At this command the necessary powder tanks in the magazines are opened; powder is passed through the scuttles to the lower handling room; the powder cars are filled and raised to the top of the hoists. BuOrd safety precautions require that in each flamtight stage of the ammunition train, not more than one charge per gun, for the guns being supplied through that stage, shall be exposed or allowed to accumulate. Simultaneously the projectile-handling room crews are loading the projectile hoists with the required type of projectiles.

This command further implies that whenever an empty powder car is returned to the lower handling room, or that whenever an empty stage in the projectile hoist appears, the crew must reload immediately until otherwise ordered.

The first command to the gunroom crew is "Load." The gun captain, on the loading platform, unlatches

the breech-operating lever and pushes it down. The primerman, under the breech, assists the gun captain in locking the breech down. The gun captain wipes the mushroom and inspects to see that the bore is clear. As soon as the "Bore clear" signal is given, the gun captain shuts off the gas ejector valve and signals the cradle operator to span the tray (lower it to loading position).

At the same time the primerman inserts a primer into the open firing lock. The rammer operator rams the projectile (fig. 7E5) until it is seated and withdraws the rammer as he opens the powder hoist door. The powder-car operator tilts 1 of the powder-car trays, and 3 bags of powder roll across the door onto the spanning tray. The gun captain and cradle operator guide the powder bags across the door and space them out on the spanning tray. The powder car lowers about 23 inches and stops automatically, and the remaining three bags of powder are rolled onto the spanning tray. (Fig. 7E5.)

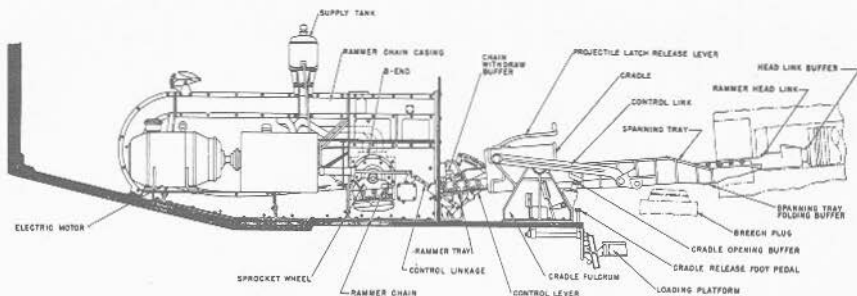

FIGURE 7E6.—Rammer mechanism (16-inch turret).

The rammernan closes the powder-car door and carefully rams the six powder bags to place the rear-most bag not more than 4 inches from the mushroom when the breech is closed. The cradle operator folds the spanning tray as soon as the rammer is withdrawn. The gun captain releases the breech hold-down latch

and opens the air valve to the closing cylinder. He then latches the operating lever as the plug rotates to the closed position. The gun captain steps off the loading platform and operates the "ready" switch to signal that the gun is loaded and to bring the gun to gun order position.

## F. Turrets Equipped With Case Guns

### 7F1. General

Propelling charges in metal cartridge cases have a number of advantages over charges in fabric bags. Metal cases are mechanically much sturdier than fabric bags; they don't burn if exposed to a spark or momentary flame; they're much less likely to rupture and spill powder; and the complete propelling charge in its case, including powder, igniter, and primer, can be loaded into the gun in one operation, as compared with the multiple bags and separate primer required for bag-type ammunition. Consequently a turret for case guns can be designed to have a minimum of compartmentation as compared with a bag-gun turret; manhandling of powder can be reduced to a minimum—which means that automatic handling by power gear can be increased to a maximum; extra handling necessary because of the requirements of flametight integrity can be radically reduced. It follows that guns and turrets using case-type propelling charges can be designed to develop much higher rates of fire, and with smaller crews, than can those using bag-type ammunition.

Hence there has been a trend to substitute turrets and guns using case ammunition for those using bag-type ammunition, and at the same time firing rates have increased, the size of crews has decreased, and more and more operations are completely mechanized and made automatic. The ultimate design objective

is a turret which, upon signal from a remote station, will train and elevate its guns to a desired position, load its guns, commence firing when the target comes within range, and continue firing until the target is destroyed or all the ammunition expended, all without assistance from operating personnel.

At the present time the Navy has 6-inch and 8-inch case-gun turrets. The earlier 6-inch turrets require in general about as much manhandling of ammunition as does a 5"/38 twin mount. The later types of 6-inch turrets have eliminated manhandling of propelling charges after they have been loaded into the hoist; projectiles still are transferred manually from hoist upper end into gun slide. In the newest 8-inch turrets there is no manhandling of ammunition at all after it has been loaded into the hoists.

The remainder of this section will be concerned with the earlier type of 6-inch case-gun turret. The next two sections in this chapter will take up the newest types of 6-inch and 8-inch turrets. Emphasis in these discussions will be upon the novel features of the ordnance design.

### 7F2. Six-inch 47-caliber triple-gun turrets

Light cruisers of the *Brooklyn*, *Cleveland*, and *Fargo* classes are equipped with single-purpose 6-inch turrets of similar designs. The gun has a monobloc, radially expanded barrel with housing and wedge-type

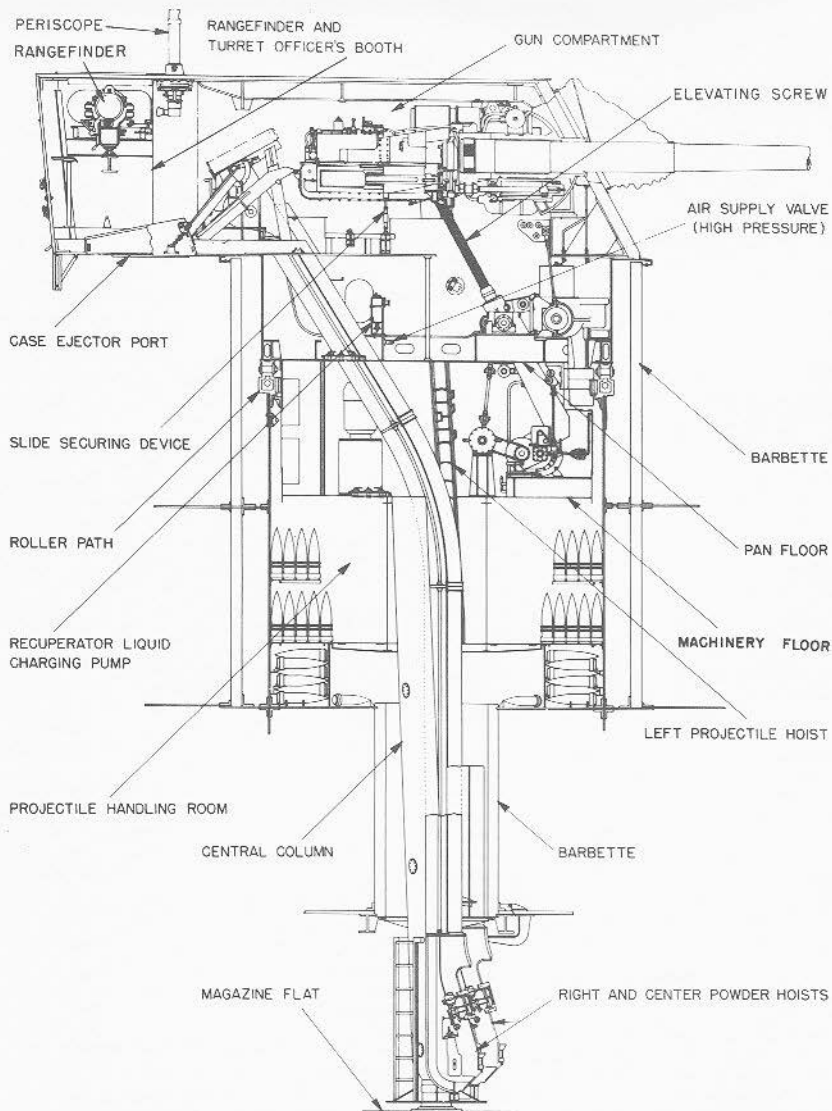

FIGURE 7F1.—Section through 6"/47 triple gun turret.

sliding breechblock. Ammunition is supplied to the gun room through 1 projectile hoist and 1 powder hoist for each gun, and is transferred by the gun crew from the top of the hoist into a loading tray in the gun slide. Although the maximum elevation of the guns is 60°, loading must be accomplished at an elevation of 22° or less because of the limitations of the ammunition-loading mechanisms and the empty-case ejection system. Gun compartment features generally resemble the smaller semiautomatic guns, such as the 5"/38 caliber which is described in the next chapter.

The gun compartment is not divided into separate gun rooms, because the inherently greater safety of case ammunition renders such minute flametight subdivision unnecessary. The rear part of the gun house, as in major-caliber turrets, includes the turret officer's

booth with rangefinder and equipment for local control of fire. The pointer's and sight checker's stations are located outboard of the left gun, the trainer's and sight setter's stations outboard of the right gun, neither station being separated from the gun compartment by bulkheads.

Levels of the turret below the gun compartment serve the same purposes as in the 16"/50 turret described above. They are, as is clearly shown in figure 7F1, somewhat simplified as appropriate to the smaller size and lighter weight of the whole assembly and each of its components. One major simplification is in powder hoist design, the charges for the 6"/47 gun being handled by an endless-chain conveyor-type hoist with open flights instead of powder cars. Elevating and training gear are of electric-hydraulic type and permit a selection of remote or local control.

## G. 6"/47 Dual-Purpose Gun and Turret

### 7G1. General

The main battery of light cruisers of the CL-144 (*Worcester*) class comprises the newest design now in service of 6-inch guns and turrets. There are 12 guns in six 2-gun turrets, all of them capable of rapid fire against either air or surface targets.

### 7G2. Turret structure

In general structure these turrets are similar to the 6-inch triple-gun turrets discussed in the preceding section, though there are minor variations (fig. 7G1). The turret foundation is built into the ship and supports the roller path, above which are the gun house and pan floor. Immediately below the pan floor are two projectile-handling levels, then the electric deck, and at the bottom is the powder flat. The barbette extends from just below the gun house to the armor deck. Interior compartmentation is not severe; there are no flametight bulkheads subdividing the gun house, whose space is divided principally by the placement of its equipment and the arrangement of the guns. The gun slides themselves are supported by deck lugs, and these in turn by gun girders and the remainder of the turret structure, as in the other turrets taken up so far.

### 7G3. Arrangement of turret personnel and equipment

Figure 7G2 shows the arrangement of ordnance equipment and crew stations in the gun house of the 6"/47 turret.

All units of both guns, except the forward portions

of the barrels and the power plants for the slide power equipment, are located in the gun house. (The slide equipment motor-pump units are located on the next level, the pan plate.) Also located in the gun house are the upper ends of the 6 ammunition hoists, 2 fuzze setting indicator-regulators, all components of the 2 elevating-gear drives and their indicator-regulator controls, and the 2 gun captain's control panels.

Other major units in the gun house are the components of the fire control equipment. These are grouped into three stations: the right and left wing stations (also called sight stations) and the turret officer's booth. The right wing station includes controls for the turret trainer and for the right gun pointer and sight setter; the left station includes controls for the checker (standby turret trainer) and for the left gun pointer and sight setter. The turret officer's booth includes the controls for the turret officer, turret captain, radar control operators, and computer operator. Almost all of the equipment is mounted either on the forward bulkhead or on the after wall of the booth.

Twenty-one members of the crew are located on the shelf plate of the turret; 10 in the turret officer's booth and 11 in the gun house. These comprise 11 turret controlmen, 3 gun-laying operators, 3 gun operators, 2 hot-case men, and 2 projectile loaders.

The 11 turret controlmen are: the turret officer, the turret captain, the talkers, the radar operators, computer operator, and two sight setters. The checker, a member of the crew in training operations only, does not man his station in battle action.

The three gun-laying operators are the right and

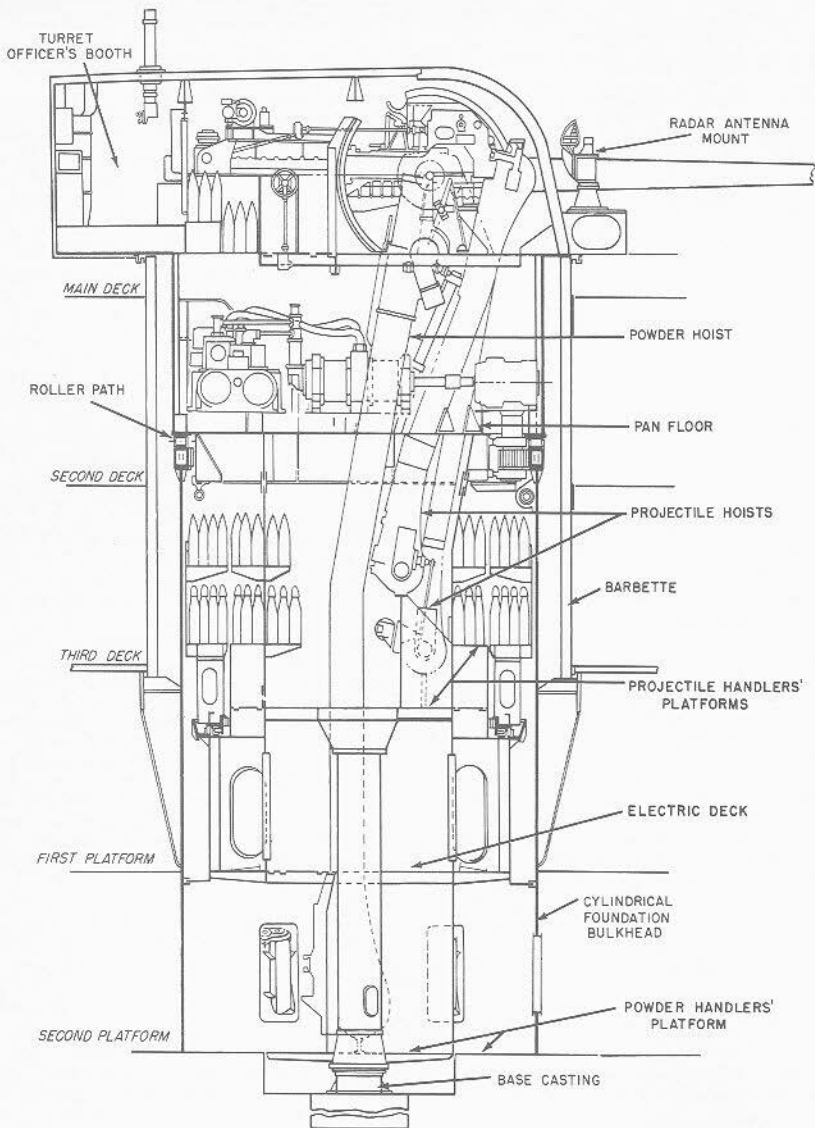

FIGURE 7G1.—Section through 6"/47 dual-purpose two-gun turret.

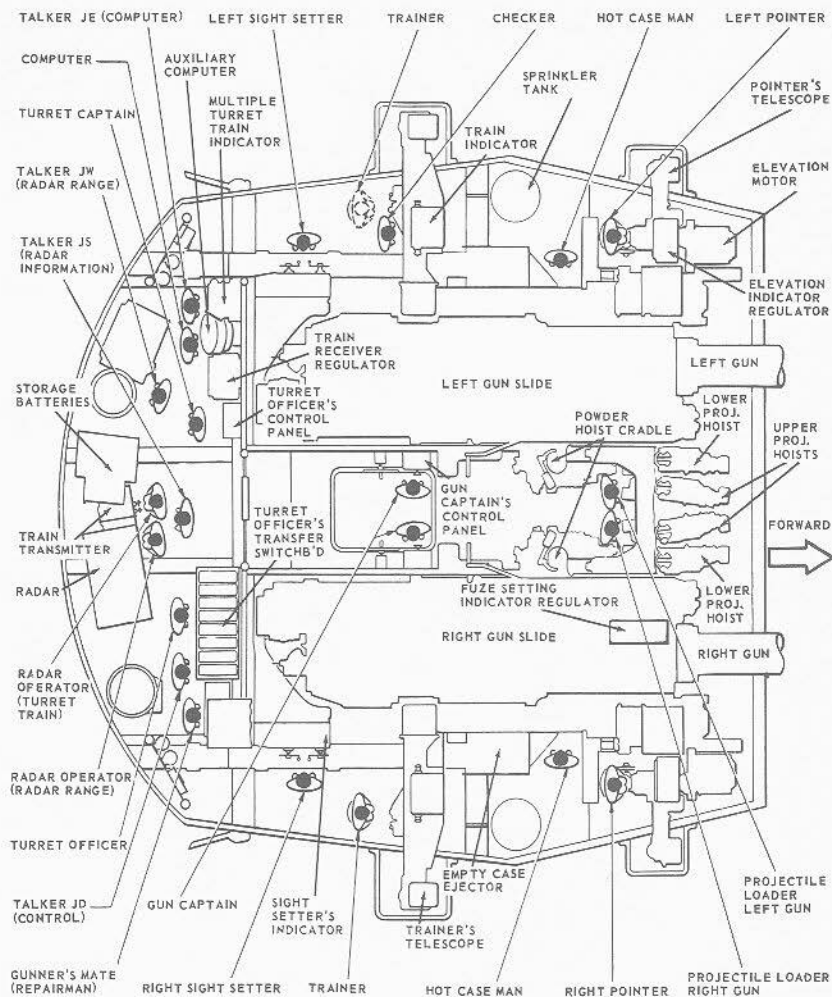

FIGURE 7G2.—6"/47 dual-purpose turret. Plan view of gun house, showing crew station and ordnance equipment arrangement. (Note: Equipment duplicated on both sides of the turret is generally labeled once only.)

left pointers, and the trainer. The 3 gun operators are the 2 gun captains, 1 for each gun, and the gunner's mate repairman, stationed in the turret officer's booth for general maintenance of the gun control equipment. His principal responsibility is trouble correction; he also aids in preparing the guns for firing, in maintaining continuous operation of the guns, and in stowing the guns.

The 2 projectile loaders are located 1 at the loading tray of each gun. They operate the fuze setting indicator-regulator when the fuze setting system is in manual control. The 2 hot-case men are located 1 on the outboard side of each gun near the case ejector.

The pan plate (not illustrated) contains most of the components of training gear drive and the hydraulic power supply for the slide power equipment, as well as some of the equipment for the hoist power drives.

The projectile-handling floor is divided into upper and lower projectile stowage flats. Much of the space at this level is taken up by hydraulic gear for the hoists and the train drive suspended from the overhead. Most of the rest is taken up by stowed projectiles and projectile hoists. Figure 7G3 shows the

upper flat. The lower flat is generally similar, except that its diagram would show only 4 hoists (2 powder and 2 projectile) instead of the 6 visible in figure 7G3. Only two of the hoists shown open into the upper flat; the powder hoists and the projectile hoists from the lower flat are enclosed tubes passing through. This turret has but 1 projectile ring assembly, but the ring has 2 tiers, 1 for each flat. Each tier is set up to stow 288 projectiles. The projectile ring power drive has 4 control stations, 1 near each projectile hoist. The controls are operated in pairs; at each level, the hoist loaders on both sides must cooperate to start the ring.

Fixed stowage capacity is 106 projectiles at the upper level, and 124 at the lower. Some sections of the upper flat are hinged so that they can be swung out of the way when the lower flat is in use.

The same crew of 7 operates on either the upper or the lower flat. It consists of a petty officer in charge and 1 projectile loader and 2 passers for each hoist being served. The loaders merely shove projectiles into the hoists, which start automatically when loaded. The passers keep the loaders supplied; they also operate the projectile ring as required.

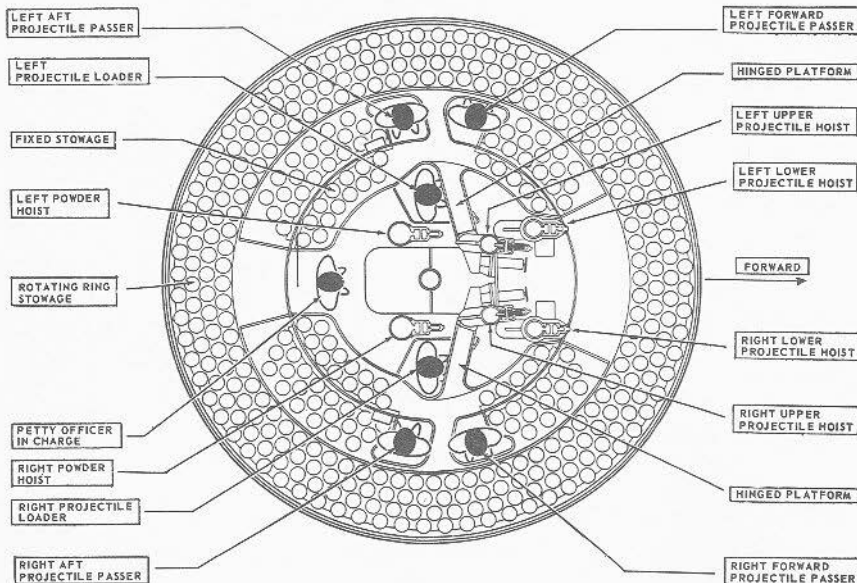

FIGURE 7G3.—6"/47 dual-purpose turret. Plan view of upper projectile flat, showing ammunition stowage, equipment, and crew stations.

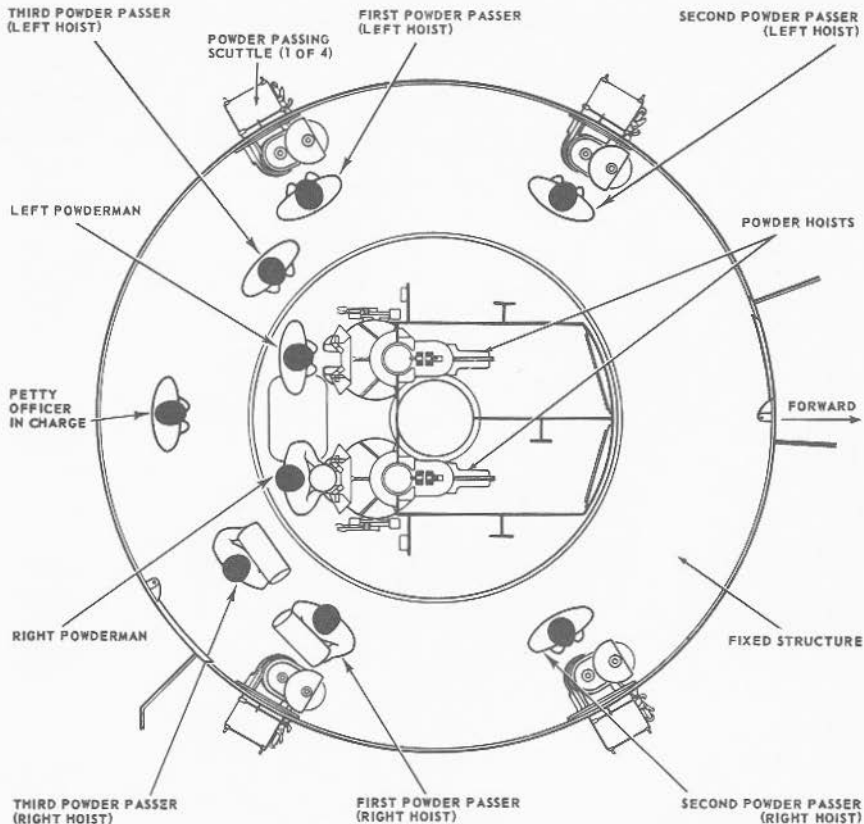

FIGURE 7G4.—6"/47 dual-purpose turret. Plan view of powder-handling flat, showing equipment and crew stations.

At the powder-handling room level, four powder-passing scuttles admit powder cases from the magazine. A crew of 9 operates in the powder-handling room—6 powder passers taking the charges from the scuttles to the powder hoists, 2 powdermen operating the scuttles at the foot of the hoists, and a petty officer in charge (fig. 7G4).

#### 7G4. Gun assembly

The right- and left-hand gun assemblies are functionally identical, though some parts are of opposite

hand. The two gun assemblies are symmetrically arranged about the turret centerline.

The 6"/47 gun used in these turrets is a monobloc radially expanded type, designed for semifixed ammunition, whose bore has 48 rifling grooves with right-hand uniform twist, 1 turn in 25 calibers.

The gun housing has a vertically sliding breechblock operated by a hydraulic cylinder, and a single spade extractor, also hydraulically operated (fig. 7G5).

The firing mechanism is designed primarily for electric primers, but it provides for percussion firing of

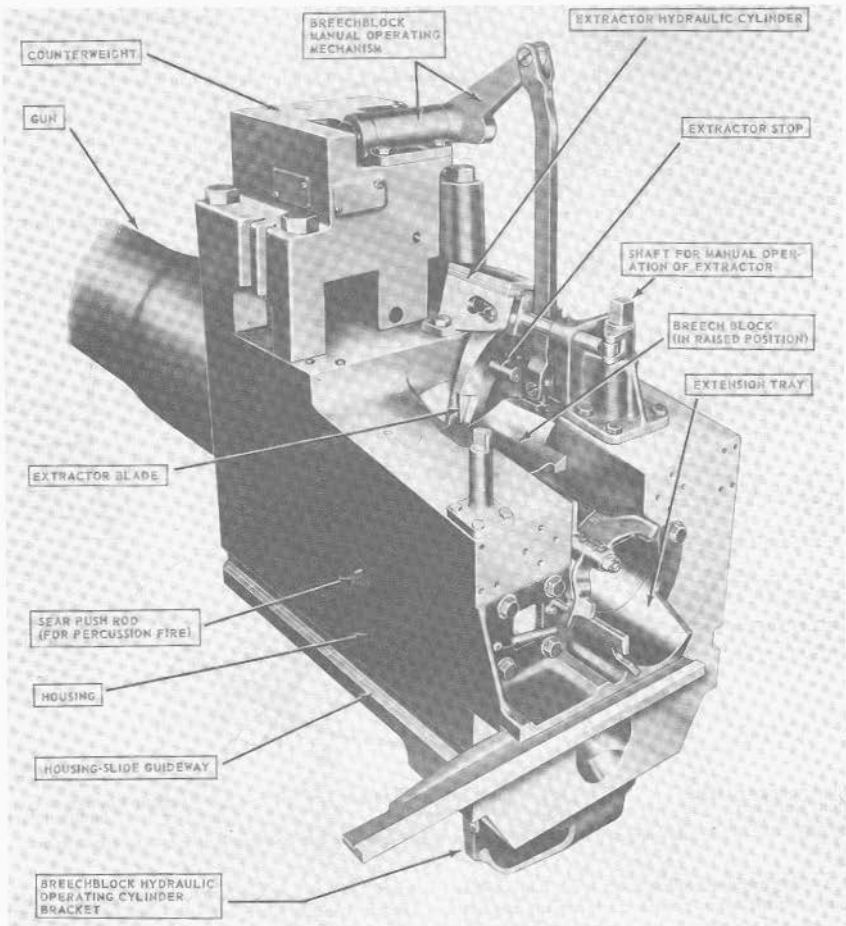

FIGURE 7G5.—6"/47 dual-purpose gun and housing (left rear view of left gun).

short cases. The breech and firing mechanism and their power-operated components normally function automatically when the gun is firing, but they can be operated manually or by power under manual control. In general, the gun assemblies resemble those of 6"/47 guns in *Cleveland* class turrets.

#### 7G5. Slide, rammer, and case ejector

In many ways, these assemblies are similar to those of the *Cleveland* class turret. This article will concentrate on the novel features. These are the mechanisms for loading the gun, fuze setting, and disposal of the empty case.

Figure 7G6 shows the slide of the left gun. Mounted atop the slide is an accumulator from which is distributed the hydraulic fluid that operates the case extractor and breechblock in the gun housing and the projectile tray, case stop, traverse carriage, and ammunition rammer-empty case ejector in the slide. Most of these slide ammunition-handling units are at least partly visible in this view; the main exception is the empty-case tray at the left side of the slide. The pump that through the accumulator supplies the hydraulic fluid under pressure that drives all these units is on the pan floor, and the fluid flows to and from the slide through the three jointed pipes under the slide.

The projectile is manually loaded into the projectile tray, and the powder case is mechanically loaded into the powder-case loading tray. The projectile tray drive unit then drives the projectile tray and fuze setter head aft. The powder-case crosshead, which is mechanically linked to the case-stop drive, engages the base of the case in the powder-case loading tray. The case stop drive for most of this operation is set to function as a braking unit; thus the projectile tray drive unit during most of its stroke aft drives the projectile and powder case against the braking effort, exerted through the powder-case crosshead, of the case-stop drive unit. This keeps the projectile's nose firmly inside the fuze-setter pot. The fuze is set during this operation.

At the end of this stroke the complete round is in the traverse carriage loading tray in the traverse carriage, which moves transversely across the slide. It is driven by the traverse carriage drive unit near the rear of the slide. It has two trays. The traverse carriage loading tray is visible in figure 7G6; the other, the traverse carriage empty-case tray, is not. The carriage has two positions. Figure 7G6 shows it in FIRE position, with the empty-case tray lined up with the gun bore to receive the empty case upon extraction; in RAM position the carriage moves so that the loading tray is lined up with the bore and the traverse carriage empty-case tray is lined up with the empty-case tray on the slide.

The functioning of these units will be further discussed when turret operation is taken up.

### 7G6. Ammunition hoists

Each gun is served by three ammunition hoists: one powder hoist, and two projectile hoists (one projectile hoist from each of the two projectile flats). The powder hoist delivers the powder cartridge directly to the gun slide completely automatically, regardless of the movement of the gun in elevation, without manhandling of the case, and without requiring that the gun be brought to a specific loading posi-

tion. The projectile hoists bring the projectiles to a point adjacent to the slide, from which they are manually transferred to the gun slide. Projectiles can be loaded at any gun elevation.

All six ammunition hoists are generally similar. All are of the continuous type in which an endless-chain conveyor, operating intermittently, automatically starts hoisting every time the hoist lower end is loaded, until the hoist is full. Each hoisting cycle lifts the projectile or powder case one stage. The hoists can also be reversed for lowering ammunition.

The powder hoist lower end is fitted with a flame-proof scuttle for extra safety. The upper end terminates in a power-driven cradle which automatically loads the propelling charges into the gun slide.

### 7G7. Fire control and power drive equipment

The 6"/47 dual-purpose turret is designed to deal with air as well as surface targets. It is capable of a maximum surface range of over 25,000 yards, and can reach targets at an altitude of over 51,000 feet when at its maximum elevation of 78°. There is no optical rangefinder in these turrets, but they are equipped with telescopic prismatic sights, periscopes, and sight-setting equipment, as well as radar and computer equipment.

The turret is driven in train and the guns in elevation by electric-hydraulic power drives controlled by receiver-regulators. The fuze setters on the gun slides are also operated by receiver-regulators. There are six designated types of turret control:

1. *Primary surface control.* The gun and turret drives are controlled by an aloft radar antenna mount or by an aloft main-battery gun director, operating in conjunction with main-battery plotting room equipment. This control has two variations: "AUTOMATIC" and "INDICATING."

2. *Primary AA control.* The gun and turret drives are controlled by an aloft main-battery gun director operating in conjunction with main-battery plotting-room equipment. This control has two variations: "AUTOMATIC" and "INDICATING."

3. *Secondary surface or AA control.* The gun and turret drives are controlled by a 3-inch battery director.

4. *Local radar control.* The drives are controlled by the radar equipment within the turret. In this method of control, the pointers control gun laying with their sights and handwheel controls: Turret train is controlled by the radar operators using the train transmitter (turret order) to send gun train orders to the receiver-regulator and to the gun train indicators.

5. *Hand control.* The gun-laying and training drives are controlled by the pointers and selected trainer using their sights and handwheel controls.

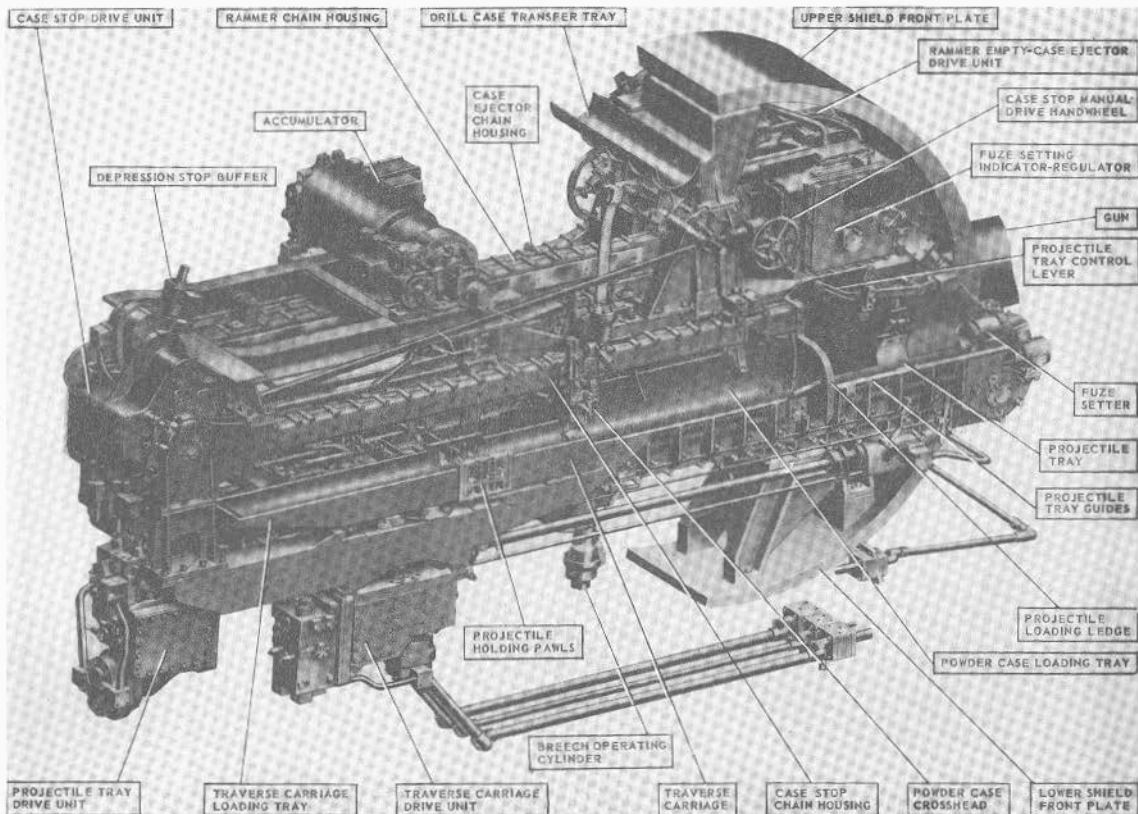

FIGURE 7G6.—6"/47 dual-purpose gun. Slide assembly. (Right rear view of left gun.)

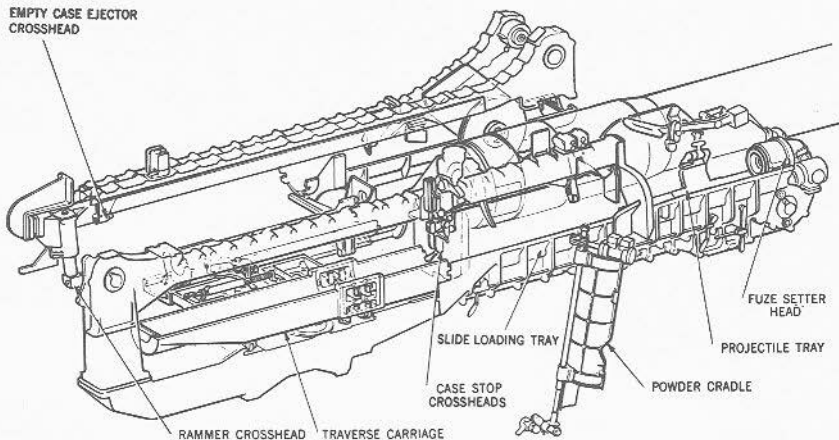

FIGURE 7G7.—6"/47 dual-purpose gun. Slide loading equipment in secured position. Powder cradle registered with hoist.

In primary surface or AA control, the turrets and their guns are controlled, in automatic control, by signals received from the controlling plotting room. Or they may be controlled and positioned in the follow-the-pointer operation, called indicating control. Either selection can be controlled from the forward or after plotting room, using any one of the aloft radar antenna mounts or main-battery directors for surface control, or using any one of the main-battery directors for AA control.

In secondary surface or AA control, the turret drive may be controlled by similar automatic and follow-the-pointer (indicating) control variations from a selected secondary (3-inch battery) director.

Turret local control methods include local radar control, hand (target-sighting) control, periscope control, and combinations of these. All of these methods use the local computer for solution of the firing problem for the proper sight angle and sight deflection for hitting the target. The computer operator gives the computed values of sight angle and sight deflection to the sight setters. The sight setters crank these quantities into their indicators to set the sights to the ordered values of sight angle and deflection.

Radar control arrangements are one of the feature innovations of the turret. The installation includes one complete radar control set in the turret officer's booth, a radar antenna, and antenna train drive. This installation enables the turret to ascertain target direction, distance, course, and speed. It is a range-finding system that completely displaces the optical range-

finder of earlier turret design, and provides new alternative methods for local control. The radar signal beam to the target can be employed to yield line-of-sight and range data.

Unlike other 6-inch turrets, the elevating gear is of the arc and pinion type (same principle as the 5"/38 mount) instead of the screw and nut type (like that in the 16"/50 turret).

#### 7G8. Other facilities

The 6"/47 dual-purpose turret is fitted with the usual electrical illumination, power, data-transmission, alarm, signal, and communications circuits. It is equipped with 2 compressed-air pipe systems—one a 125-psi system for supplying air to the gas ejector and sprinkling systems, and the other a 3,000-psi supply for the counter recoil air-replenishing system for replenishing accumulator air, and for charging the emergency air flasks.

The turret also has 2 self-contained exhaust systems for the empty-case ejectors and 2 ventilating systems which supply air under forced draft to all turret levels. It is equipped with an elaborate sprinkling system which can spray water at all ammunition stowage points as well as in the ammunition hoists and at the gun breeches. The sprinklers are supplied with water under pressure, and function either automatically in case of fire, by remote control from several stations, or manually. The turret also contains drainage, hydraulic fluid filling and clarifying, and heating systems.

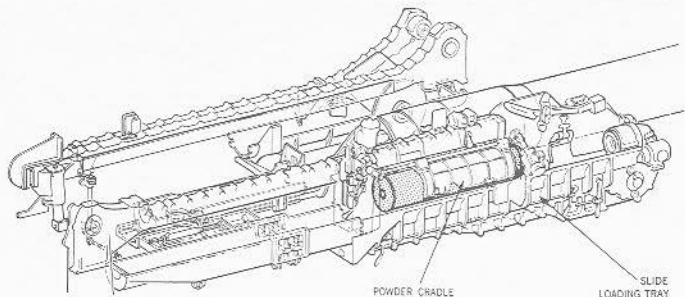

FIGURE 7G8.—6"/47 dual-purpose gun. Powder cradle latched to slide.  
PROJECTILE TRAY  
CONTROL LEVER

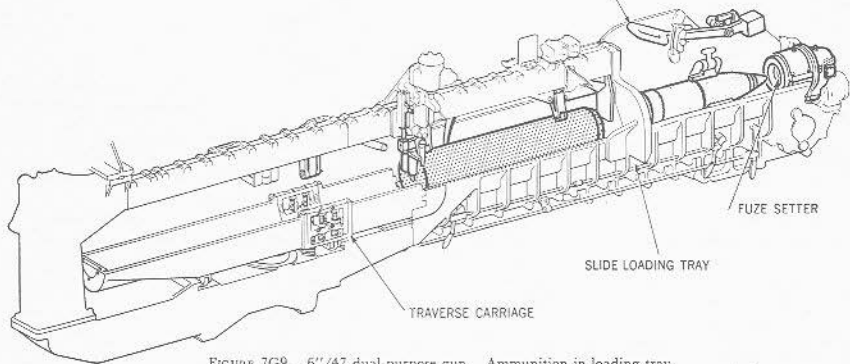

FIGURE 7G9.—6"/47 dual-purpose gun. Ammunition in loading tray.

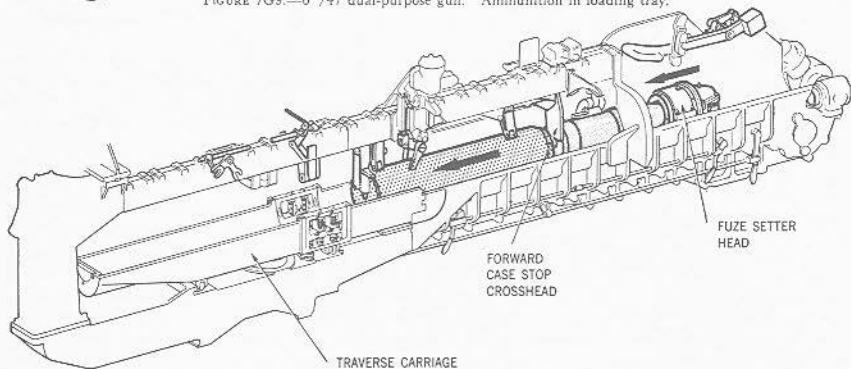

FIGURE 7G10.—6"/47 dual-purpose gun. Ammunition moving aft.

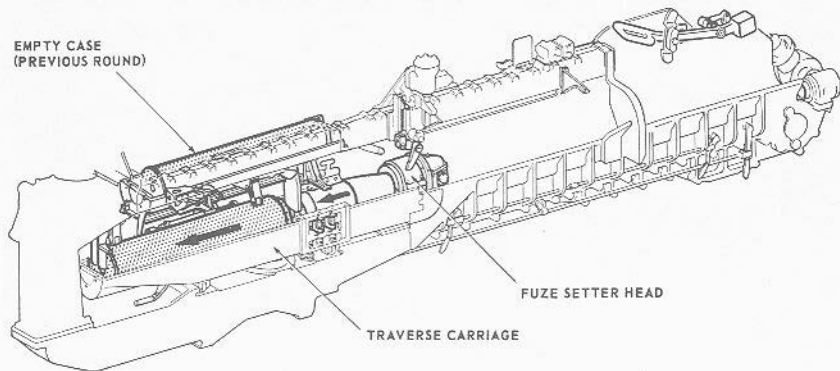

FIGURE 7G11.—6"/47 dual-purpose gun. Ammunition in traverse carriage.

### 7G9. Turret operation

This article will be concerned with ammunition supply, loading, gun firing, and extraction operations. Operations concerned with fire control, casting loose, and securing the turret will not be taken up. The student is referred to OP 760 for this information, and for further details on all aspects of this type of turret.

When the ammunition hoists are filled, a powder case goes into the cradle and a projectile goes into the projectile hoist upper end. When the powder cradle receives a powder case from the hoist, it automatically

raises, latches to the slide, and ejects the case into the slide loading tray (fig. 7G8).

The projectile loader then manually transfers the projectile from the hoist to the slide. With both the powder case and the projectile in the slide, the projectile loader pulls down the projectile-tray control lever to start the projectile tray and fuze-setter head moving aft.

The tray and fuze setter force the projectile and case to the rear of the slide against the braking action of the case stop (figs. 7G9, 7G10, and 7G11). The forward crosshead of the case stop holds the projectile nose

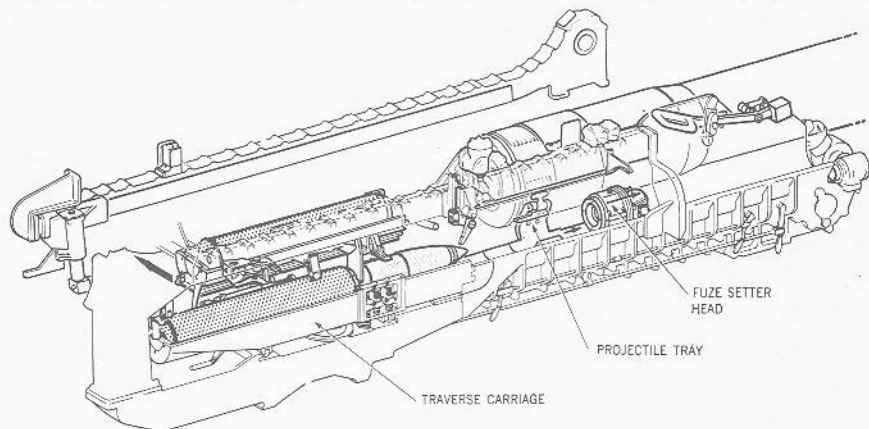

FIGURE 7G12.—6"/47 dual-purpose gun. Traverse carriage moving to ram position. Fuze setter head and projectile tray moving forward.

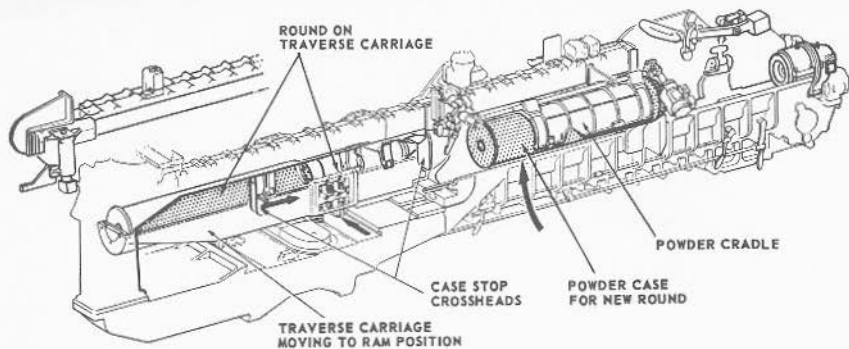

FIGURE 7G13.—6"/47 dual-purpose gun. Traverse carriage and case stop movement.

seated in the fuze-setter head, and the fuze setter functions to set the fuze as the projectile travels aft.

After the ammunition has moved all the way aft into the traverse carriage (fig. 7G11), the fuze-setter head remains in contact with the projectile fuze until the empty case from the previous round has been extracted and is latched in the empty-case tray.

The projectile tray and fuze setter head then move forward, clearing the traverse carriage (fig. 7G12). This allows the traverse carriage to start toward ram position.

The traverse carriage continues toward ram position and clears the return path of the case-stop cross-

heads which were pushed to the rear by the rearward movement of the ammunition. The powder cradle, during the previous ammunition movements, has received another case, raised it, and latched to the slide ready for the next cycle.

As the traverse carriage reaches ram position, the projectile tray is forward and the case stop is nearing its forward position. (Fig. 7G13.) The projectile, being manually loaded, may or may not be in the tray at this instant. The rear case-stop crosshead, upon reaching its forward position, initiates the powder-case ejection from the cradle to the slide loading tray. (Fig. 7G14.)

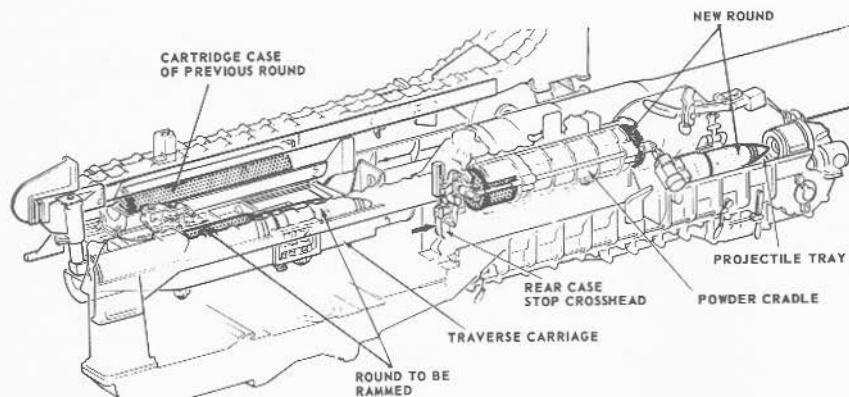

FIGURE 7G14.—6"/47 dual-purpose gun. Traverse carriage at ram position.

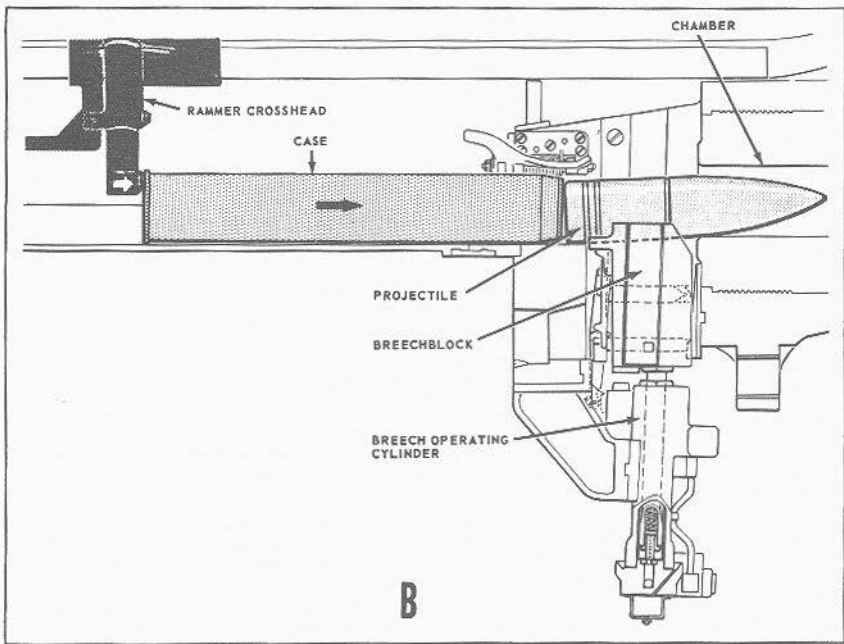
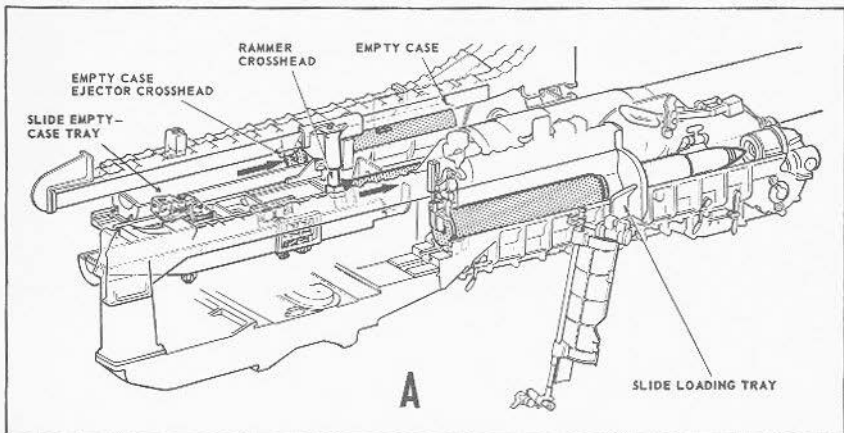

FIGURE 7G15.—6"/47 dual-purpose gun, Ramming.

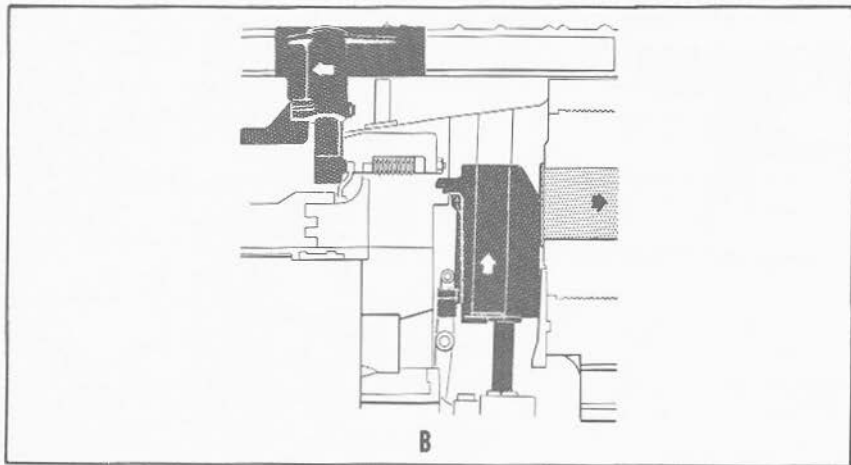
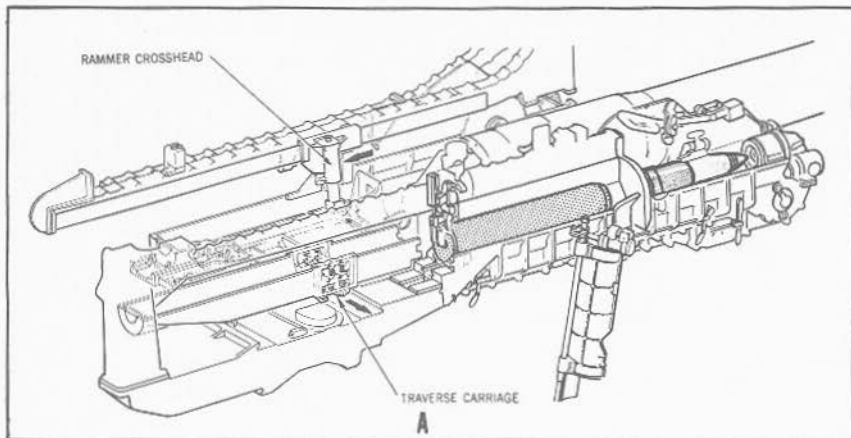

FIGURE 7G16.—6"/47 dual-purpose gun. Breechblock closes; rammer retracts; traverse carriage shifts to fire position.

Next, the rammer drives the round into the chamber. At the same time, the empty-case ejector crosshead pushes the empty case from the preceding round from the traverse carriage empty-case tray into the slide empty-case tray. By this time the next round is on the slide loading tray. Figure 7G15 (A) shows the operation of slide units in ramming.

Figure 7G15 (B) shows the ramming action from a slightly different point of view. This is a cross-section view of the round being rammed past the breechblock into the chamber.

When the rammer crosshead reaches the end of the ram stroke, the traverse carriage shifts back to fire position. See figure 7G16 (A). At the same time,

the breechblock starts closing. When the block has moved up far enough to hold the ammunition in the chamber, the rammer retracts. See figure 7G16 (B). As the breechblock rises, the slope of the ways and guides in which it moves wedges the case securely in the chamber. When the breechblock has risen to its fully closed position, it is locked by the breech bolt (not illustrated), and the firing pin of the cocked firing mechanism contacts the primer of the powder case.

The gun ordinarily fires electric-primed ammunition; the only percussion primers used are those in short cases for clearing the gun. When the gun fires, it moves in recoil and counterrecoil (the two strokes require about 0.5 second altogether) under the control of the recoil brake and recuperator mechanism, which are generally similar in principle to those described elsewhere in this course. During the counterrecoil stroke the breechblock is mechanically unlocked; a valve ports hydraulic fluid to the breech operating cylinder to lower the block shortly before the end of the counterrecoil stroke.

When the breechblock is hauled down to its fully open position by the breech operating cylinder, it cams open a valve that activates the extractor cylinder; the fired case is extracted from the chamber (fig. 7G17) and is thrown aft into the traverse carriage empty-case tray. At the same time the gas-ejector valve is cammed open. The breechblock then rises slightly to the position it had at the time of loading, camming the extractor cylinder valve to permit the extractor to return to its seated position. The gas-ejector valve is automatically closed by a timing arrangement as the breechblock rises to loading position. The same linkage also actuates an interlock to permit repetition of the cycle just described.

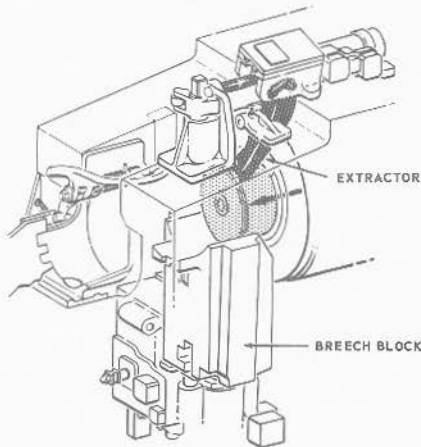

FIGURE 7G17.—6"/47 dual-purpose gun. Case extraction.

The fired case remains in the traverse carriage empty-case tray until the next round is rammed. See figures 7G14 and 7G15 (A). Then it is pushed forward by the case-ejector crosshead into the slide empty-case tray. Then comes the last manual operation in the gun's operating cycle: The hot-case man picks up the case from the slide empty-case tray and drops it into a power-driven conveyor (not illustrated) called the empty-case ejector, which sends the empty out through a door in the rear of the turret.

## H. 8"/55 Rapid-Fire Gun and Turret

### 7H1. General

At the present time the closest approach to the completely automatic turret described earlier in this chapter is the 8-inch 55-caliber rapid-fire gun and turret. These are the largest United States naval weapons now in service using case ammunition. Three such turrets are installed on *Salem* class heavy cruisers.

In this type of 8-inch turret, structural and space arrangement designs differ substantially from those of bag-gun turrets like the 16-inch turrets taken up earlier in this chapter. They are equally different from 8-inch bag-gun turrets on cruisers of similar type (for example, *Baltimore* class). This difference is due in part to the use of case-type ammunition, and

in part to the design types and details of the guns and ammunition-handling equipment. The ammunition and equipment designs do not require flameproof bulkheads separating the guns, the control stations, and the powder service.

The foundation structure, barbette, and magazine designs are quite similar to those of earlier heavy cruisers, differing principally in the magazine stowage provisions and powder-passing scuttles for powder cases instead of powder bags.

In their ordnance feature, however, the turrets are entirely new. The guns operate automatically, and require no attendants in the gun compartment. They fire at three times the rate of the comparable 8-inch

three-gun turrets of the *Baltimore*s. Other features are: comparatively fast gun laying and turret train drives; loading at all angles, while gun laying; substitution of radar range-taking equipment for optical rangefinder; automatic fuze setting; local radar control; and other flexible fire control arrangements for

local and remote control. Because it uses case-type propelling charges, many of the flameproof integrity construction features are eliminated—unlike the *Baltimore* class bag-gun turret of the same caliber, the powder hoist system is single-stage and the gun deck is not compartmented, though scuttles separate the han-

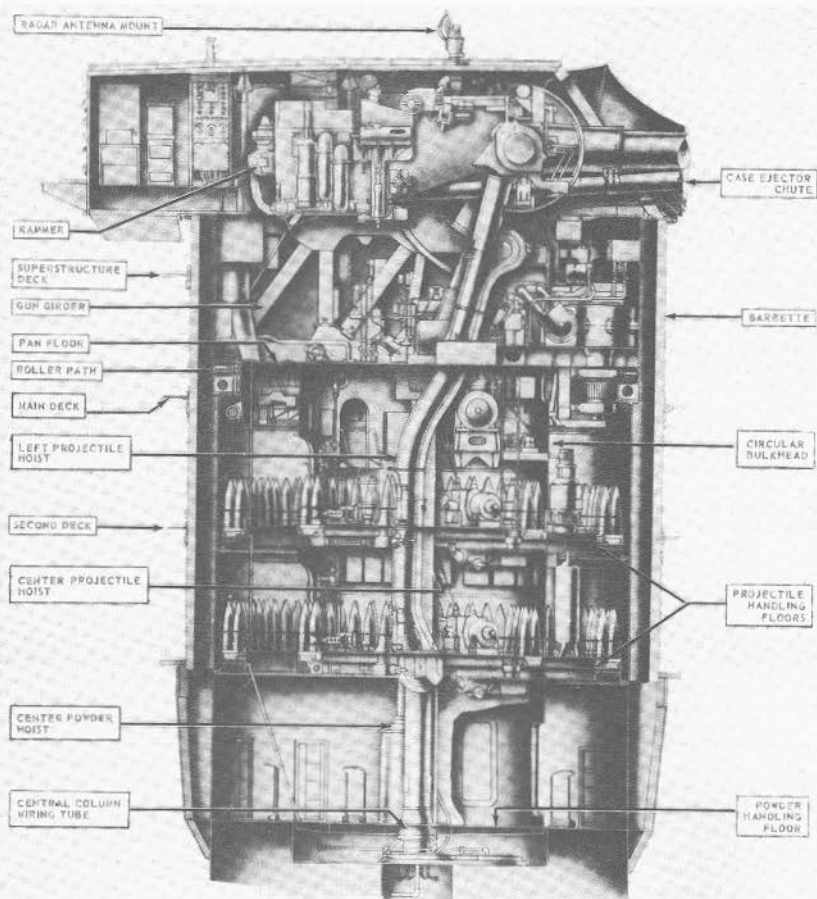

FIGURE 7H1.—8"/55 rapid-fire turret. Cross section.

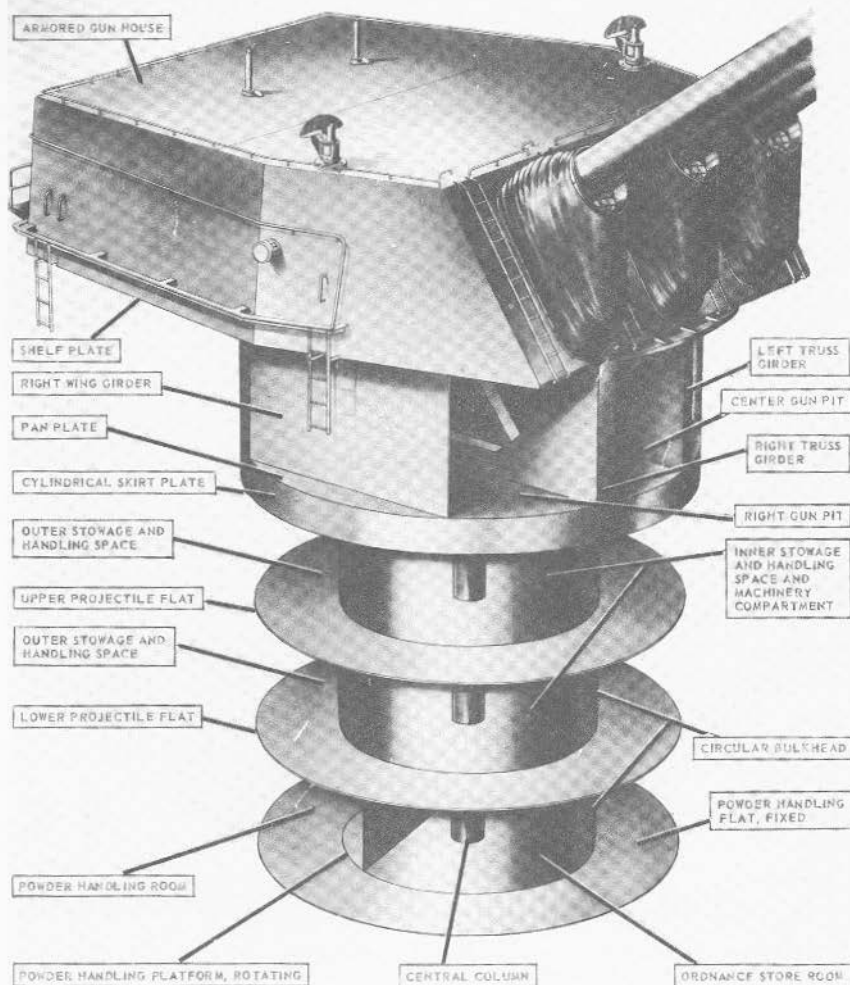

FIGURE 7H2.—8"/55 rapid-fire turret. Rotating structure (simplified).

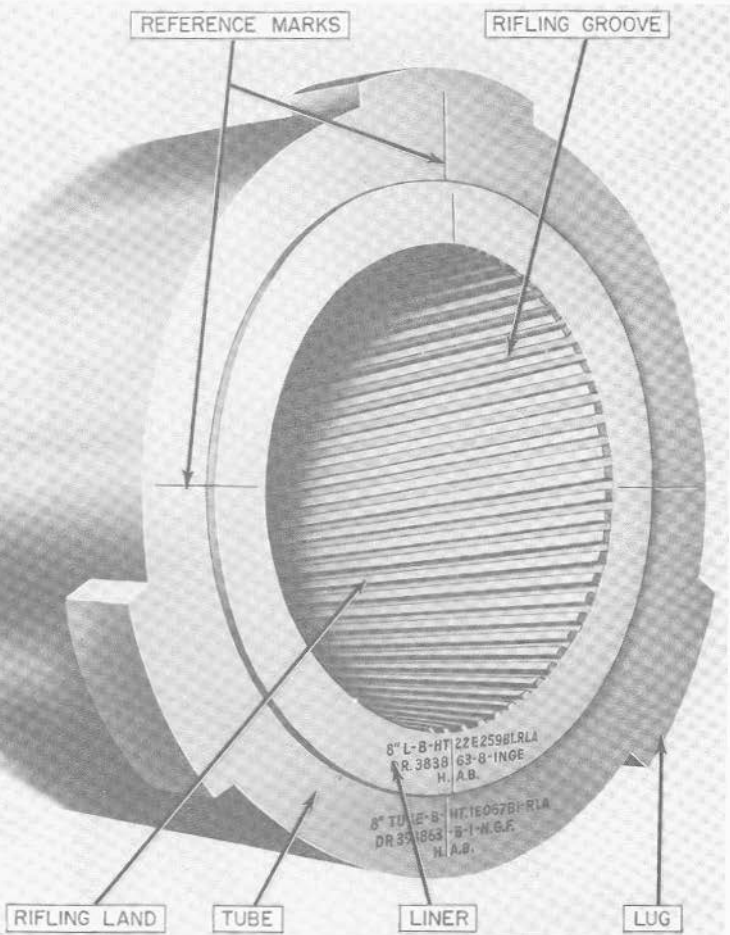

FIGURE 7H3.—8"/55 RF gun and turret. Muzzle, showing rifling and lugs.

dling room from the magazine. Because the guns use case ammunition, there is a case-ejection mechanism—a continuous-chain conveyor unit below the slide which pushes the cases out an empty-case tube under the gun.

The training mechanism of this turret is of the usual type, but it has an arc-and-pinion type of elevating gear instead of the elevating-screw type.

As to ammunition-handling facilities, the projectile flats each have two projectile rings, plus an improved type of parabuckling mechanism. Moreover, the guns incorporate completely mechanical ammunition-handling arrangements that make it unnecessary for the crew to handle or even touch the ammunition, once it has been loaded into the hoists.

### 7H2. Structure and space arrangement

As with earlier designs, the fixed-turret structure includes a foundation which supports a roller path, and an armor barrette which protects all levels of the turret between the armor deck and the gun house. The rotating structure is topped by a gun house; under this, the levels are the pan plate (which forms the bottom of the gun pits), two projectile flats, and a powder-handling room. There is no separate electric deck; the equipment that usually occupies such a deck is mostly inside the circular bulkheads that enclose the central part of the turret at the projectile-flat levels (figs. 7H1 and 7H2).

### 7H3. Gun

The gun is a combination type, 2-piece, 8-inch 55-caliber design consisting of a tube and rifled liner. It is a "loose" assembly. The liner is fitted for convenient removal and replacement on board ship. It is designed to withstand a pressure of nineteen long tons per square inch. Its rifling is of uniform right-hand twist with 64 grooves and 1 turn in 25 calibers. The powder chamber and breech are designed for semi-fixed ammunition.

Figure 7H3 shows the muzzle details, including the three lugs which anchor the jacks that are used to haul out the liner for replacement.

### 7H4. Gun supporting elements

The gun supporting structures are of the usual turret type—gun girders (fig. 7H2) which support the deck lugs (fig. 7H4) into which the gun slide trunnions fit. The slide trunnions pivot in roller bearings in the deck lugs (fig. 7H4).

The trunnion arrangements of the slide include journals for mounting two cradle units. These are the upper ends of the ammunition hoists.

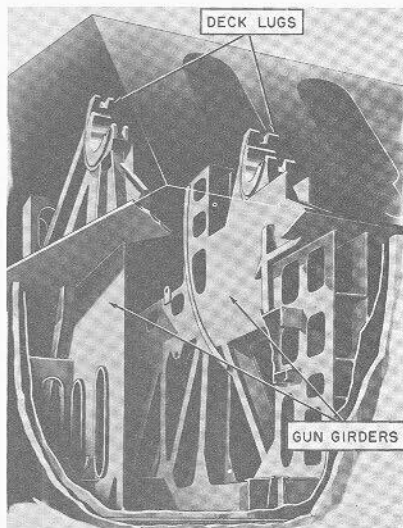

FIGURE 7H4.—8"/55 RF gun and turret. Gun-supporting construction.

### 7H5. Gun housing and breech mechanism

Figures 7H5 and 7H6 illustrate the anatomy of the housing and breech mechanism with the breech open and closed. The gun housing is a rectangular alloy steel forging. It is attached to the gun shoulder and rear cylinder by a bayonet-type joint. The housing has vertical guide ways for the breechblock. The guides have a slight forward slope to make the breechblock seat the projectile as it rises.

The breech mechanism consists of a vertically sliding power-operated breechblock, an electric firing mechanism, a power-operated mechanical case extractor, hydraulic cylinders and valves to drive these components in normal breech operation, and manually operated mechanisms to supplement the power system.

The breechblock is a rectangular steel forging similar in general design to other vertical sliding breechblocks. Its top surface has a longitudinal concave area that forms an extension of the ramming tray (fig. 7H6). A horizontal fore-and-aft bore through its middle houses the firing pin assembly. The breech-

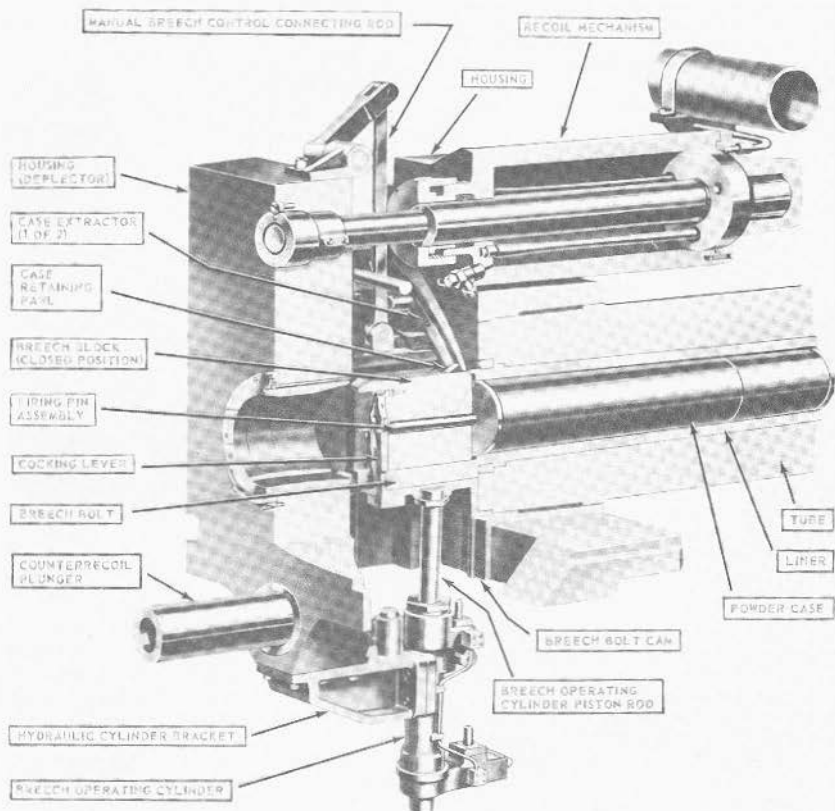

FIGURE 7H5.—8"/55 RF gun and turret. Gun housing and breech mechanism. Cross section, breech closed.

block is moved vertically in the housing ways by a hydraulic cylinder. When closed (top position, as in figure 7H5), it is locked by a spring-loaded rectangular bar—the breech bolt.

The breech bolt is released from this position by a rack-and-pinion gear arrangement (fig. 7H17) actuated by an inner release bar during the automatic cycle. (It can also be released manually.) The breech bolt and bolt cam (fig. 7H5), together perform this locking operation, plus that of retracting and holding the firing pin when the breechblock is not closed, and that of

tripping one of the breechblock hydraulic system operating valves.

The spring-loaded case-retaining pawl in the top of the breechblock fulfills its function as the rammer retracts. It holds the case in the chamber until the breechblock rises.

The firing pin assembly (fig. 7H5) extends longitudinally through the breechblock. It is for electrical firing only, though it can be rigged for percussion firing in emergency. The spring-loaded firing pin is retracted by the cocking lever (fig. 7H6) until the

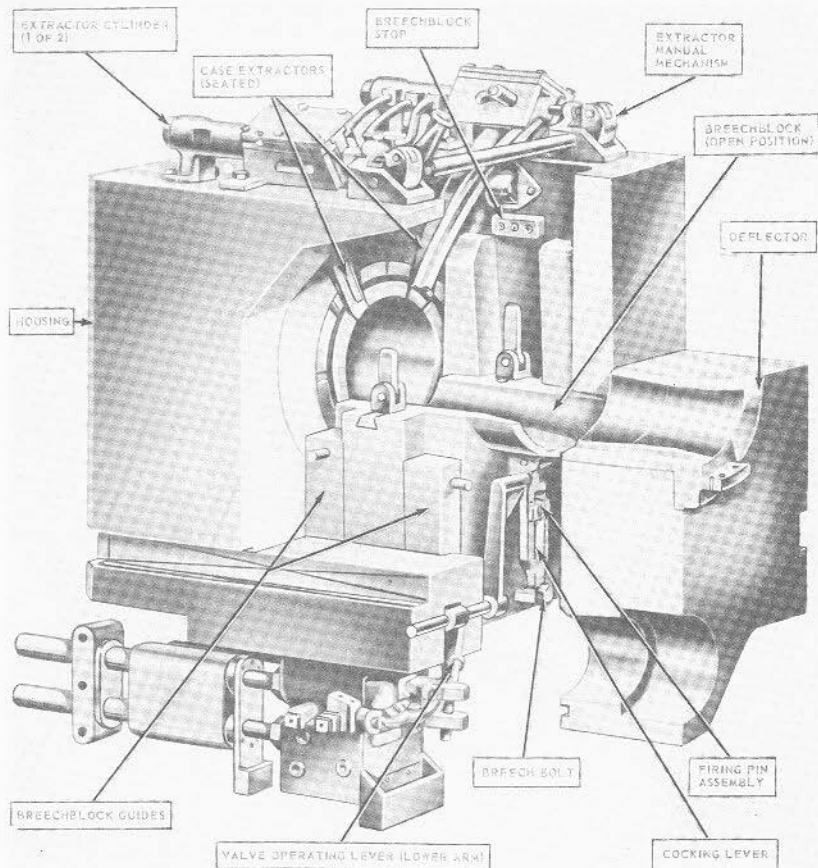

FIGURE 7H6.—8"/55 RF gun and turret. Housing and breech mechanism. Cut-away view, breech open.

breech is closed and locked. Its spring then pushes the pin forward through a hole in the front face of the block so that it contacts the powder-case primer.

The case-extractor mechanism has 2 extractor spades, operated by 2 hydraulic cylinder units bolted on top of the gun housing (fig. 7H6). Suspended in the breechway, the lower end or toe of each fits into

a recess of the cartridge rim seat of the gun. The back of each spade is curved so that the spade rocks to move the toe aft when the cylinder hauls the upper end forward during extraction. The extractor-operating mechanisms are spring loaded to return the spades to the cartridge rim seat after extraction. In normal operation, the extractor functioning is controlled by

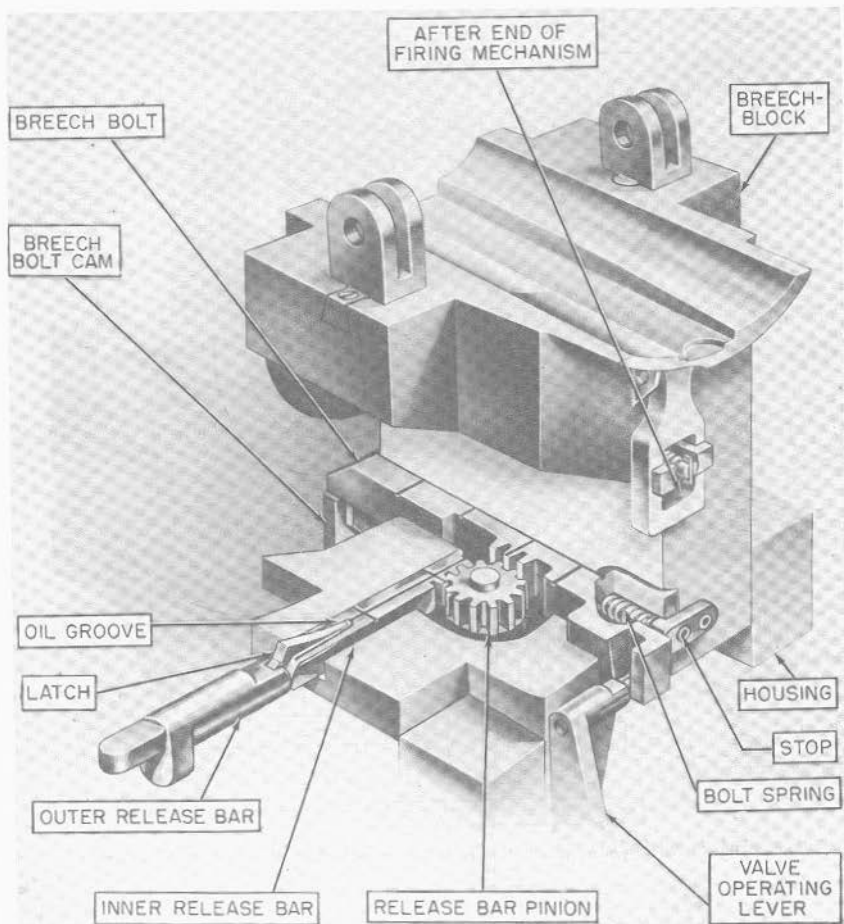

FIGURE 7H7.—8"/55 RF gun and turret. Breech bolt and bolt release mechanism. (Cut-away view. Cocking lever omitted.)

electrical switches and solenoids actuated by the breechblock as it nears the bottom of its downward movement.

The hydraulic system for raising and lowering the breechblock consists principally of a breech-operating cylinder, piston, and piston rod attached to the bottom of the breechblock (fig. 7H5). Valves in a valve block under the breechway control hydraulic fluid flow into the cylinder. The valves are positioned mechanically by a valve-operating lever; this, in turn, is actuated by the movements of the breech bolt. (Part of this linkage is shown in figures 7H6 and 7H7.) The breechblock has 2 open positions—1 for ramming (top of block aligned with bottom of chamber), and a lower one for extracting.

Manual breech-operating devices provide for auxiliary or emergency operation of the breech mechanism. Unlocking and locking the breech, resetting the breech control valves, controlling extractor functioning, and opening and closing the breech can be done manually.

#### 7H6. Slide and slide power equipment

The gun slide (fig. 7H8) supports the gun in a cylindrical bearing and two parallel rails. The slide is fitted with a hydraulic recoil brake and hydro-pneumatic recuperator of types already discussed elsewhere in this book. The slide trunnions fit into bearings in the deck lug. The slide also contains power-operated units which accept ammunition from the hoists, ram it into the chamber, and dispose of extracted cartridge cases.

The slide power equipment includes the breech-operating mechanism, the ammunition transfer trays, and the rammer and case-ejector hydraulic operating units, all of which receive hydraulic fluid from a hydro-pneumatic accumulator. This unit consists of a large vertical cylinder and two air flasks mounted at the side of the slide. An extensive system of hydraulic pipes connects it to all operating units and to a pump mounted with its electric motor on the upper projectile flat. This system continuously delivers power throughout all gun-loading and gun-firing operations.

Hydraulic power operations of the gun units are controlled by limit and interlock switches and valve-operating solenoids on the breech, rammer, tray, hoists, and case-ejector mechanisms, and control switches of the gun captain's control panel in the turret officer's booth. This gun-loading control system enables all loading and firing actions to be performed without attendants in the gun compartment and during gun-laying movement.

#### 7H7. Ammunition hoists

Each of the three guns of the turret has a projectile hoist on its right and a powder hoist on its left. Both

kinds of hoist are of the electric-hydraulically driven endless-chain and sprocket type, and in principle resemble the dredger hoist used in 5-inch mounts. Since the projectile and powder hoists are similar in general construction and principle, only the projectile hoist is shown in the figures (fig. 7H9).

The upper end of each hoist terminates in a *cradle*—a tubular unit suspended from a journal on the slide trunnion and arranged to swing between the top of the hoist and the side of the slide. In this swinging movement the cradle lower end is guided by a curved rail (not shown in the figures) mounted on the gun girder. When the cradle swings up to the slide, it latches there and moves with gun-laying action until the projectile or powder case is ejected. Then it moves to the hoist, and latches in alignment with the hoist tube, permitting the hoist to feed it another projectile or powder case.

Each cradle has a pawl at its open end and a large spring-ram device at the trunnion end. When the hoist lifts a projectile into the cradle, the spring ram is compressed and a pawl latches the projectile so that it cannot move out unless the pawl is depressed. A remotely controlled fuze setter is located in the projectile cradle.

The powder hoist has, at its lower end, a flameproof scuttle consisting of a revolving cylinder with two compartments 180° apart. When one compartment faces into the hoist tube, the other faces outward. An electric drive controlled by a crewman rotates the cylinder 180° when a powder case has been loaded into the outer compartment, to transfer the case inward to be hoisted.

#### 7H8. Ammunition-handling operations

Each 140-pound metal powder case contains the complete propelling charge for an 8-inch gun. The cases are moved in small trucks, rather than by hand carrying.

The powder-handling room is not divided by flame-tight bulkheads, but forms one large enclosure. Propelling charges are transferred from the magazine through the powder-handling room bulkhead by rotary scuttles. Crewmen load the charges into hand trucks, push them to the hoists, and unload them into the rotary scuttles (described in a previous paragraph) at the powder-hoist lower ends.

The projectile hoist can be loaded at either projectile-flat level. Projectile hoist operation is normally completely automatic. Loading the hoist automatically starts its hydraulic drive to raise the ammunition one flight (if the empty cradle is waiting at the upper end). The hoists are also capable of emergency

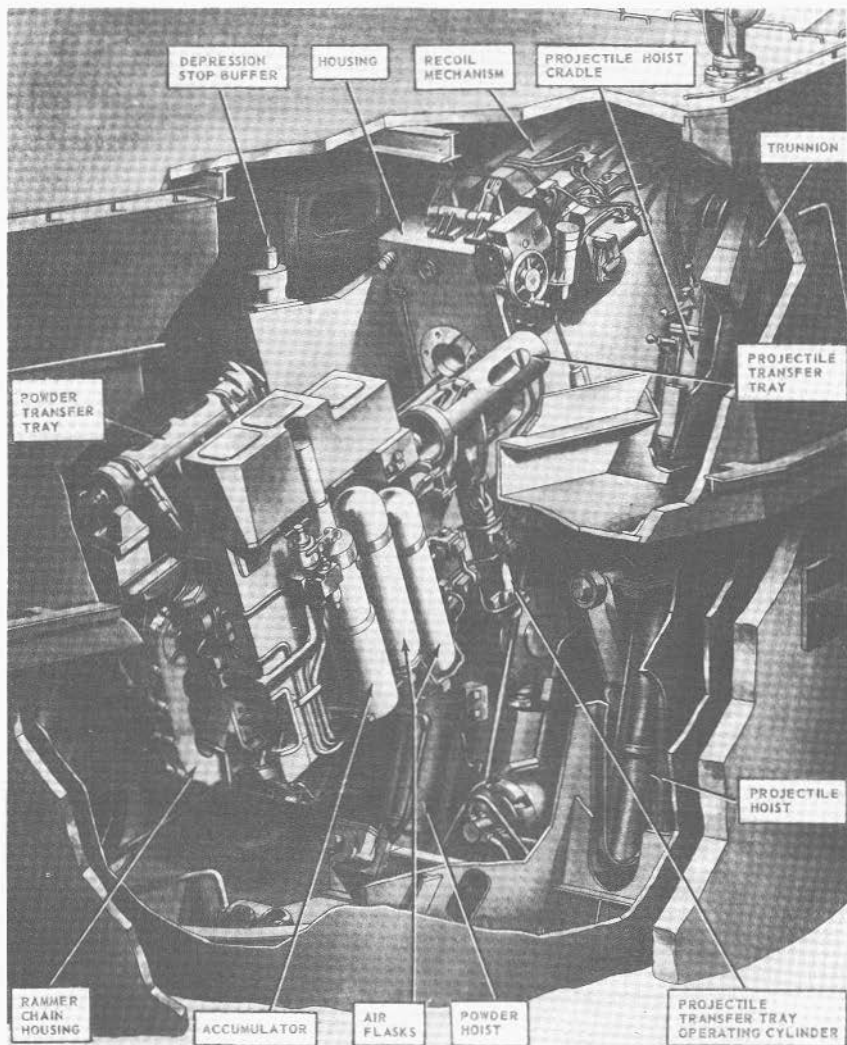

FIGURE 7H18.—8"/55 RF gun and turret. Right rear view of slide (installed).

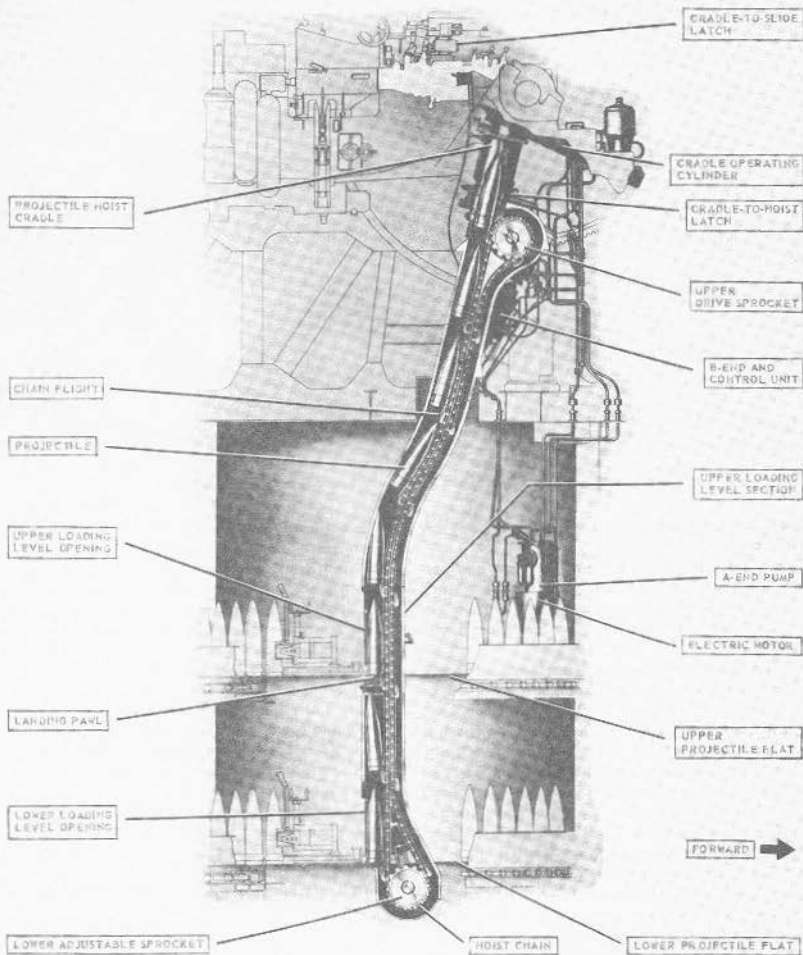

FIGURE 7H9.—8"/55 RF gun and turret. Projectile hoist.

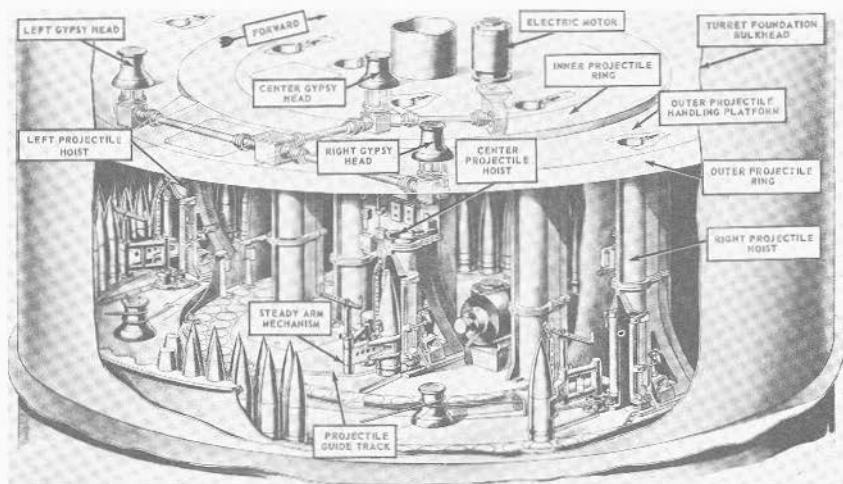

FIGURE 7H10.—8"/55 RF gun and turret. Parbuckling gear and projectile rings.

manual control and can be used for lowering ammunition.

Figure 7H10 illustrates the projectile ring and parbuckling gear layout in the *Salem* class turret. Much of the gear crowding the interior of this turret not shown in the illustration. Inside the turret foundation bulkhead are:

1. The *outer projectile ring* (capable of independent rotation and powered by an electric-hydraulic drive).
2. The *outer projectile-handling platform* (part of the turret rotating structure) on which are mounted the right and left projectile hoists, and the 3 gypsy heads and 2 *steady arm mechanisms* (1 for each projectile hoist) used in parbuckling.
3. The *inner projectile ring* (independently driven by an electric-hydraulic power drive).
4. The central part of the turret rotating structure, with the center projectile hoist and its steady arm, the power hoists, the central column, and various other gear.

Only the two projectile rings are used for projectile stowage.

#### 7H9. Gun-loading equipment

Most of the loading machinery that serves ammunition to the 8-inch RF gun is shown in figure 7H11.

The projectile-hoist cradle, which receives the projectile from the projectile hoist, can swing up and down (arrow *A*) between its hoist or receiving position (aligned with the hoist), shown in the figure, and its discharge position, aligned with the tubular projectile transfer tray. The projectile-hoist cradle is rotated on a journal bearing surrounding the trunnion by a hydraulic cylinder (shown in fig. 7H19). The cradle locks in either position, regardless of gun elevation angle, and regardless of whether or not the gun is moving in elevation. There is a similar powder-hoist cradle (not shown in the figure) on the left trunnion, which has similar positions with respect to the powder hoist and the powder transfer tray.

The powder transfer tray and projectile transfer tray, when swung outboard as in figure 7H11, are in firing position. These trays can swing (arrows *B, C*) inboard, under the thrust of hydraulic cylinders (the cylinder for the projectile tray is visible in figure 7H18) to ramming position, in which they are aligned with each other, with the gun breech, and with the rammer.

When in firing position, the trays allow clearance for the gun to recoil and for the ejected cartridge case to move along the spanning tray into the empty powder-case tray. Note that the spanning tray, which is structurally a part of the housing, moves in recoil with the housing under the empty powder-case tray, which remains stationary.

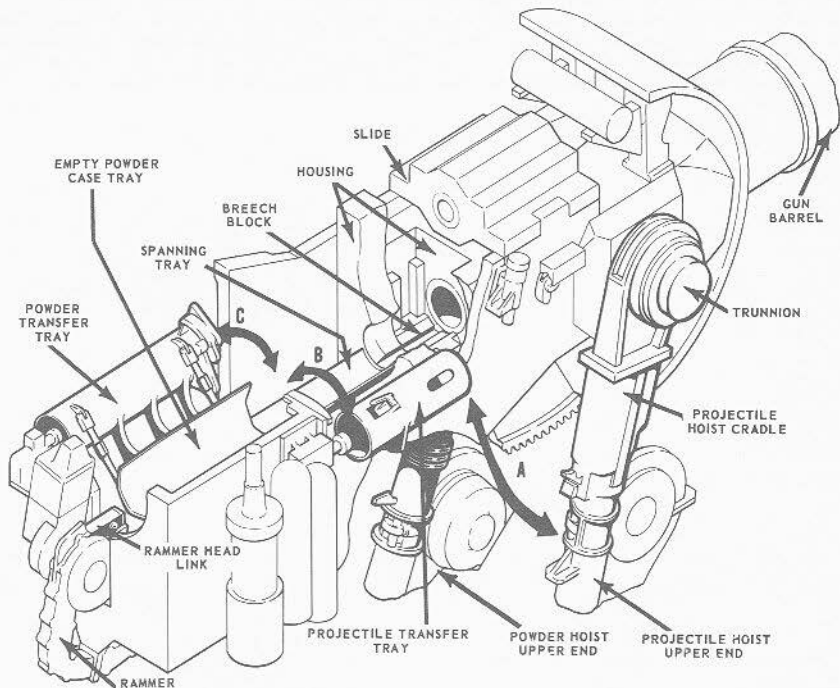

FIGURE 7H11.—8"/55 RF gun and turret. Loading equipment.

When the powder transfer tray swings inward (arrow C), the empty powder-case tray, which is linked to the transfer tray and moves with it, goes downward to the case-ejection mechanism. This mechanism is a hydraulically driven chain-conveyor unit which thrusts the empty cases outside through a tube under the gun barrel to fall to the ship's deck.

#### 7H10. Operating cycle

Following is the sequence of operations in normal automatic operation, beginning with the hoists full, and with gun-loading equipment in the positions shown in figure 7H11.

1. *Hoists load cradles.* First of all, the projectile and powder hoists lift a projectile and powder case into their respective cradles, compressing a heavy coil spring in each (fig. 7H12). (Since about the same

thing happens in both cradles, only the projectile cradle is shown in the figure. The fuze setter is not shown.) Spring-loaded pawls hold the projectile and case in the cradles.

2. *Cradle movement to discharge position.* Next, each cradle swings upward to discharge position, automatically latching in alignment with the transfer tray (fig. 7H13). (Only the projectile side is shown.)

3. *Transfer to transfer tray.* When the powder cradle reaches this position, interlock switches close a circuit which causes immediate hydraulic retraction of the retaining pawl. The compressed coil spring in the cradle thereupon throws the powder case into the transfer tray.

Operations on the projectile side are similar, except that retaining pawl retraction is synchronized to occur only when the breech is open (fig. 7H14). This de-

layed delivery of the projectile keeps the projectile fuze in contact with the fuze setter until the last possible moment, and so reduces fuze dead time. It also simplifies operations in case of misfire or other malfunctions.

When the projectile has been thrown into its transfer tray, a buffer brings it to a controlled stop, and a

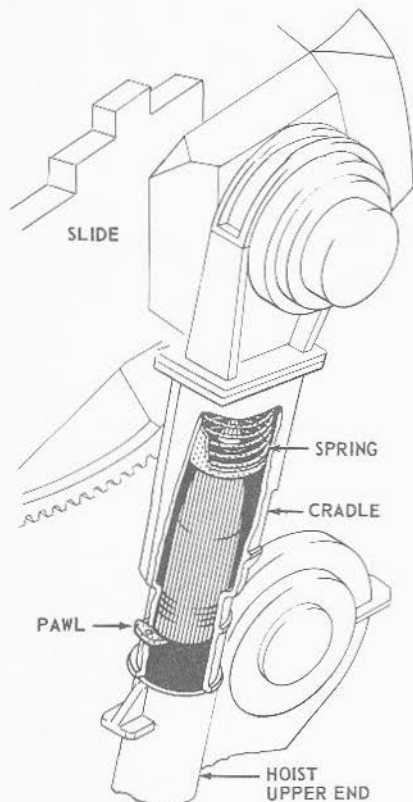

FIGURE 7H12.—8"/55 RF gun and turret. Projectile loaded into hoist cradle.

retaining latch keeps it from slipping forward too soon. Other cam and stop devices similarly keep the powder case in place within its tray, and, at the right time, position the projectile and case properly for

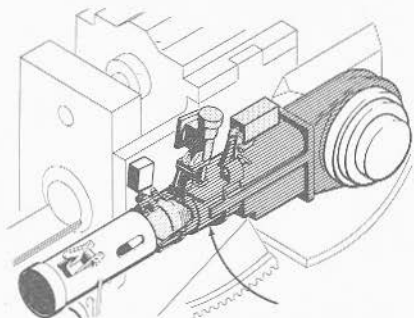

FIGURE 7H13.—8"/55 RF gun and turret. Cradle moving to discharge position.

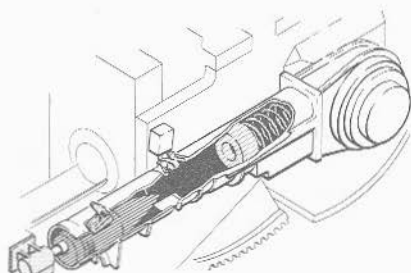

FIGURE 7H14.—8"/55 RF gun and turret. Projectile in transfer tray, cradle still in discharge position.

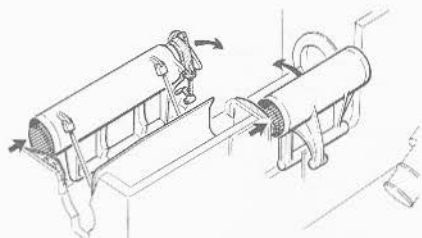

FIGURE 7H15.—8"/55 RF gun and turret. Trays moving toward ramming position.

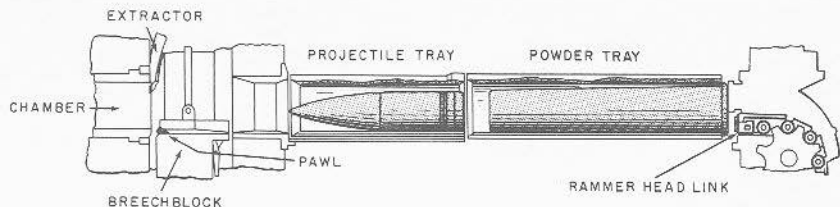

FIGURE 7H16.—8"/55 RF gun and turret. Start of ramming action.

ramming. Meanwhile, the cradles automatically swing down to receiving position, ready to be reloaded by their hoists.

4. *Transfer trays to ramming position.* At the same time, or when other interlocking elements permit, the two trays are hydraulically swung into ramming position, and the powder case and projectile are properly positioned for ramming. Figure 7H15 shows how the trays move toward ramming position.

5. *Ramming.* When the trays are lined up with the open breech and the rammer (fig. 7H16), the rammer rams the projectile and powder case into the gun chamber, then automatically reverses and retracts. The spring-loaded pawl at the top of the breechblock engages the cartridge-case rim to prevent the case from sliding rearward into the path of breechblock closing movement (fig. 7H17).

6. *Breech closing.* (Fig. 7H18.) When the rammer chain has cleared the breechblock, the block rises. Breechblock movement wedges the powder case into the chamber.

7. *Breech locking.* (Fig. 7H19.) Positive stops limit breechblock closing movement at a position that synchronizes with the end of bolt travel on the bolt

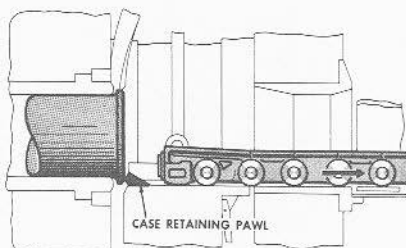

FIGURE 7H17.—8"/55 RF gun and turret. Rammer retracting; case-retaining pawl functioning.

cam. The spring-loaded bolt moves forward across the top of the cam to breech-locked position, and the cocking lever and firing mechanism move to firing position.

8. *Gun firing.* In its firing position, the pin is in contact with the primer of the powder case. As the firing circuit is closed, the current ignites the primer and the powder charge.

9. *Gun recoil, gun counterrecoil, and breech opening.* During counterrecoil a cam in the slide causes

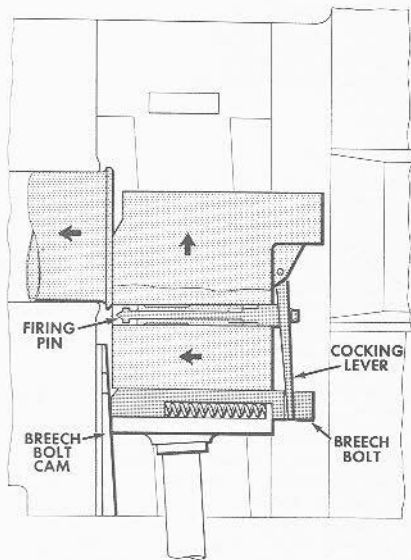

FIGURE 7H18.—8"/55 RF gun and turret. Breech closing; case being wedged.

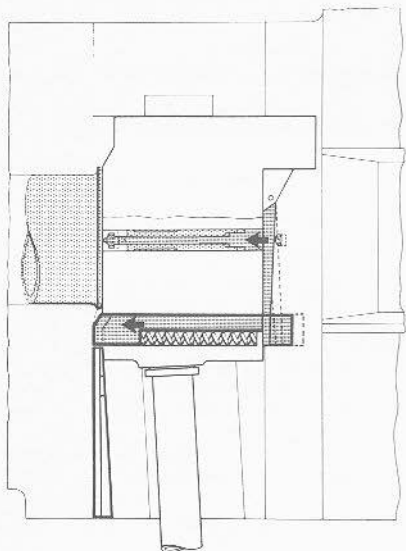

FIGURE 7H19.—8"/55 RF gun and turret. Breech closed and locked: firing pin contacting primer.

two push bars to rotate the gear in the block and retract the breech bolt (fig. 7H20). This retracts the firing pin, unlocks the block, and causes the breechblock cylinder valves to port hydraulic fluid into the cylinder to lower the block.

10. *Case extractor operation.* As it nears full open position, the breechblock actuates a valve that admits hydraulic fluid to the extractor hydraulic cylinder. In full open position, the top of the breechblock is below the path of the empty powder case when it is extracted (fig. 7H21). Both extractors move to extract the case and eject it to the rear (fig. 7H22). Then they retract.

11. *Gas ejector operation.* When the case extractors are actuated, a mechanical linkage (not illustrated) opens the blow valve of the gas ejector. This ports air *via* the pilot valve to three orifices in the breechway. The air automatically shuts off.

12. *Breechblock to loading position.* The breechblock moves upward approximately 0.75 inch to gun-loading position.

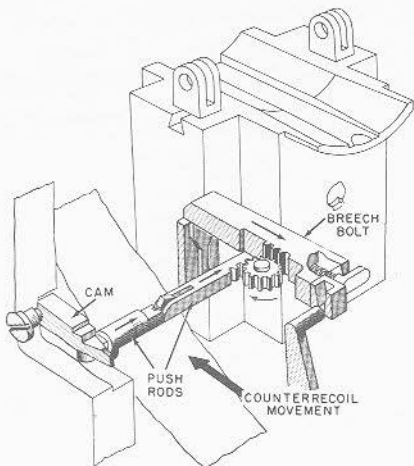

FIGURE 7H20.—8"/55 RF gun and turret. Breechblock unlocking in counterrecoil movement.

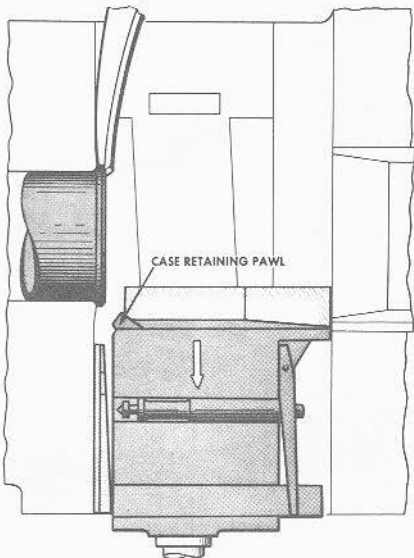

FIGURE 7H21.—8"/55 RF gun and turret. Breech open (in case-extraction position).

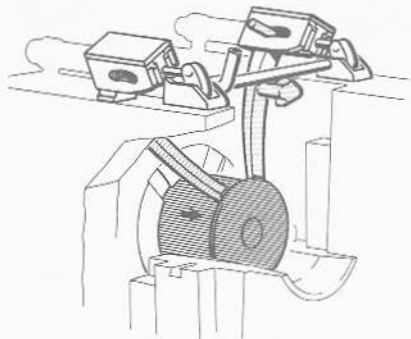

FIGURE 7H22.—8"/55 RF gun and turret. Extractor action.

13. *Empty-case tray operation.* As the empty case comes out of the chamber (fig. 7H23), the guide keeps it from being thrown out of the slide. The hydraulic buffer takes the impact of the case, and the two retaining latches (one is shown in the figure) hold it in place in the empty-case tray.

By now the powder and projectile trays have been reloaded. Arrival of the empty case in its tray actu-

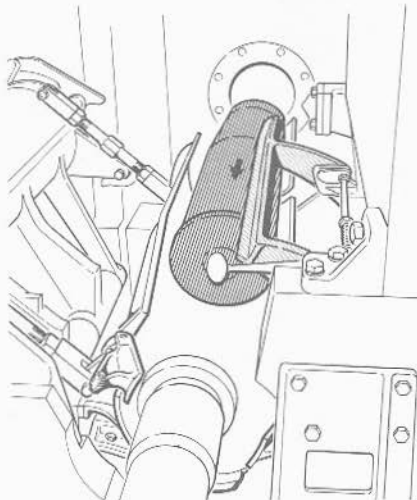

FIGURE 7H23.—8"/55 RF gun and turret. Empty-case tray receives extracted case.

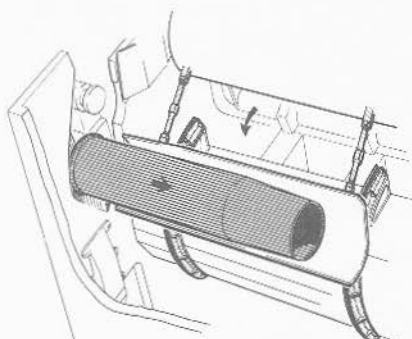

FIGURE 7H24.—8"/55 RF gun and turret. Empty-case tray moving downward.

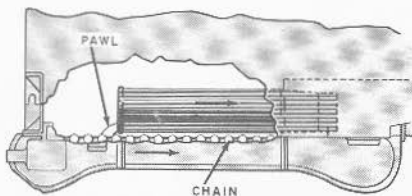

FIGURE 7H25.—8"/55 RF gun and turret. Empty case in ejector

ates 1 of a series of interlocked electric switches, and the 2 reloaded trays move toward ramming position once more, ready for the next shot. As the powder-case tray swings downward, so does the empty-case tray (fig. 7H24). The case-retaining latches are cammed open, and the empty case is dumped into the case-ejection mechanism under the gun slide.

14. *Case ejector action.* The case ejector consists principally of a sprocket-driven endless chain with two equally spaced pawls, and a tube leading outside the turret under the gun, with a spring-loaded door at its end. When the empty case lands on the ejector, it depresses a pawl which closes a switch; this causes the case-ejector drive to move the chain forward one flight (one-half the length of the chain) (fig. 7H25). As the chain moves forward, 1 of its 2 pawls pushes the powder case into the tube. Since the capacity of the empty-case tube is only five cases, eventually the cases at the front end are ejected past the door

out to the ship's deck (fig. 7H26). A special drain disposes of sea water that may be shipped in heavy weather while the door is open.

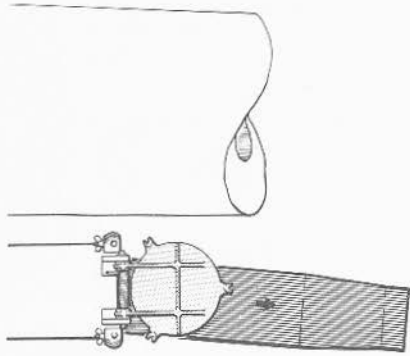

FIGURE 7H26.—8"/55 RF gun and turret. Empty case being expelled from ejector tube.

#### 7H11. Training and elevating gear

The guns of this turret are laid by arc-and-pinion type elevating gear. The training gear is similar to that of other turret installations.

The training units include the training gear electric-hydraulic drive equipment, a train receiver-regulator, and control station equipment for the turret training system. There are 3 elevating gear assemblies, 3 gun elevation indicator-regulators and power drives, and 1 pointer's control station equipment for the gun elevating system.

Turret training and gun laying are controlled much as in the 6"/47 dual-purpose turret described earlier in this chapter. The pointer's and trainer's control equipment provides for three methods of control—*automatic*, *local*, and *hand*. In *automatic*, the electric-hydraulic train and elevation power drives are under the immediate control of the fire control directors, or some other source of gun order signals. In *local*, the power drives are controlled through the receiver-regulator or indicator-regulators by the trainer's and pointer's handwheels. In *hand* control, the receiver-regulator and indicator-regulators are bypassed, and the trainer's and pointer's handwheels di-

rectly control A-end tilt to regulate the functioning of the elevating and training power drives.

#### 7H12. Fire control

In general, fire control arrangements are quite similar to those possible with the *Worcester* class 6"/47 turrets described in the preceding section. The turret battery can be controlled by main-battery directors through forward or after plot, or by the secondary-battery directors. Turrets II and III have their own radar equipment for determining target location, including range. Turret II can function to aim the guns of turret I. (This is called "hi-turret" control, because turret II is several feet higher than turret I.) Each turret can also function in local control.

#### 7H13. Crew stations and operations

Forty-four men are required to man the battle stations of this turret installation. Twenty-seven men of this complement, located in the levels below the gun house, operate the ammunition service to the guns; six others, stationed in the gun house, control and maintain gun operations; these 33 men are identically employed in all methods of turret control.

The balance of the organization consists of 2 gun-laying operators and 10 turret controlmen, all stationed in the gun house. These 12 men have varying duties, depending on the method of control. In this installation, in fully automatic operation, the operations of the guns are controlled from the turret officer's booth in the rear of the turret from control panels and switchboards.

Eighteen members of the crew are located in the gun house. (fig. 7H27). There are 10 turret controlmen, 2 gun-laying operators and 6 gun operators.

The 10 turret controlmen are the turret officer, turret captain, computer operator, 2 radar operators, 3 talkers, sight setter, and checker. The checker is a member of the crew in training operations only; his station is not manned in battle action.

The two gun-laying operators are the pointer and trainer.

The 6 gun operators are the 3 gun captains, their assistants, and the electrician. This electrician is stationed in the gun house for general maintenance of control and communications circuits. His principal responsibility is trouble correction and aid in maintaining continuous operation of the guns.

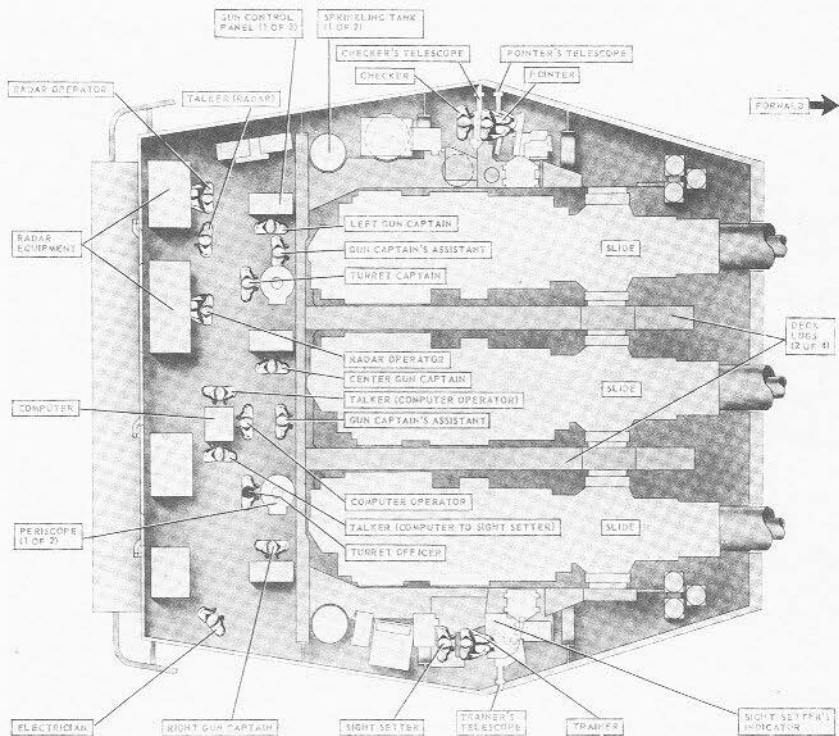

FIGURE 7H27.—8"/55 RF gun and turret. Gun house crew stations.

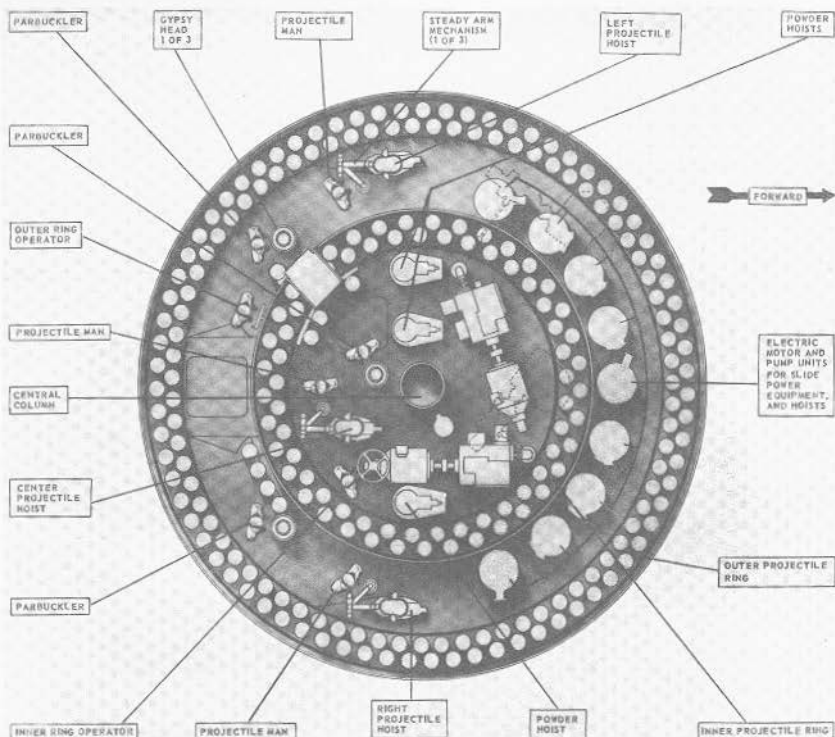

FIGURE 7H28.—8"/55 RF gun and turret. Upper projectile flat crew stations.

Eight members of the turret organization are stationed in the upper projectile flat—3 in the inner compartment, 2 at the rear right and 3 at the rear left of the outer compartment (fig. 7H28). They are all engaged in supplying projectiles to the hoists, with the ring operators maintaining supply to all.

The lower flat is set up similarly, except for an addi-

tional crewman—a roving electrician with maintenance duties. Figure 7H29 shows the station arrangements of the remainder of the turret organization. Ten men conduct the powder transfer service; three men serve each hoist under supervision of a petty officer.

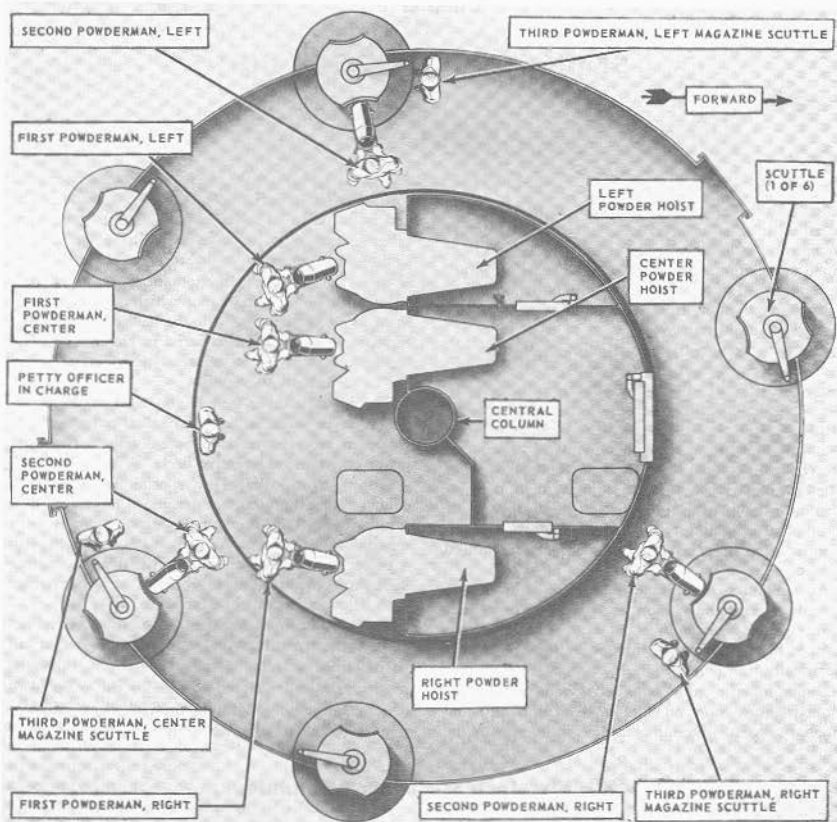

FIGURE 7H29.—8"/55 RF gun and turret. Powder-handling room crew stations.

## Chapter 8

# SEMIAUTOMATIC WEAPONS

### A. General

#### 8A1. Introduction

Semiautomatic guns are case guns in which energy stored during recoil is used on counterrecoil to operate the breech mechanism, eject the empty case, and later to close the breech and (if required) cock the firing mechanism. Power for loading, ramming, and firing is supplied separately and requires independent control by members of the gun crew.

The cycle of operation is as follows: (1) the gun recoils after firing, and energy is stored in the counter-recoil system; (2) during counterrecoil the breech-block is automatically lowered and the empty case is extracted; (3) after the next case is rammed into the chamber, the block is automatically raised to close the breech; and (4) the firing mechanism is cocked, either when the block is lowered or when it is raised, depending on the design of the gun, and the gun is then ready for another operating cycle. The firing rate of semiautomatic guns depends largely upon the time required to load.

All semiautomatic guns use fixed or semifixed ammunition, depending upon their size. These guns utilize a sliding-wedge breechblock. A firing mechanism is fitted in the breechblock to fire the primer electrically or by percussion.

Semiautomatic guns are used extensively by the United States Navy on all types of combatant and auxiliary vessels. Examples of this type of gun are the

5"/38 (all types) and 5"/54 (Mark 39 only) designed for semifixed ammunition, and the 3"/50 and 5"/25 which use fixed ammunition. Although these guns differ in mechanical details, they all use the vertical sliding-wedge semiautomatic breech mechanism.

The 3"/50 caliber semiautomatic gun is a pedestal-mounted, hand-loaded weapon which is not capable of firing at a rate comparable to the newer 3"/50 caliber rapid-fire gun, which is covered in chapter 9. The former is still in use on certain types of small patrol craft and on auxiliary vessels.

The 5"/25 caliber gun is also used on an open-pedestal type single mount. The dual-purpose 5"/25 caliber is now mounted only on a few of the older heavy cruisers in the reserve fleet.

During World War II a special *1601*-type 5"/25 caliber pedestal mount was developed for use on fleet submarines. This is a single-purpose mount with maximum elevation of 40°. It is not equipped with a power drive. The ammunition is fixed, consisting of a projectile weighing 54 pounds and a cartridge with a loaded weight of 21 pounds.

The 5"/38 caliber and the 5"/54 caliber assemblies are in more general use than any of the above and will be described in more detail. The 5"/38 caliber is particularly well adapted to use for the purpose of demonstrating the operating principles generally applicable to all semiautomatic guns.

### B. Five-Inch 38-Caliber Assemblies

#### 8B1. General

The 5"/38 caliber gun is a semiautomatic, dual-purpose, pedestal- or base-ring-mounted gun which uses semifixed ammunition. The principal features of 5"/38 caliber gun assemblies are as follows:

1. Vertical sliding-wedge breech mechanism.
2. Hydraulic recoil and hydropneumatic counter-recoil systems.

3. Power-operated rammer.
4. Power-operated elevating and training gear.
5. Movable-prism telescopes.
6. Power-operated fuze-setting projectile hoist (except on mounts of type 4 listed in article 8B27).
7. Power-operated powder hoist on all twin mounts and some singles.

The operating principle of the 5"/38 caliber gun is the same for all of the installations found on naval

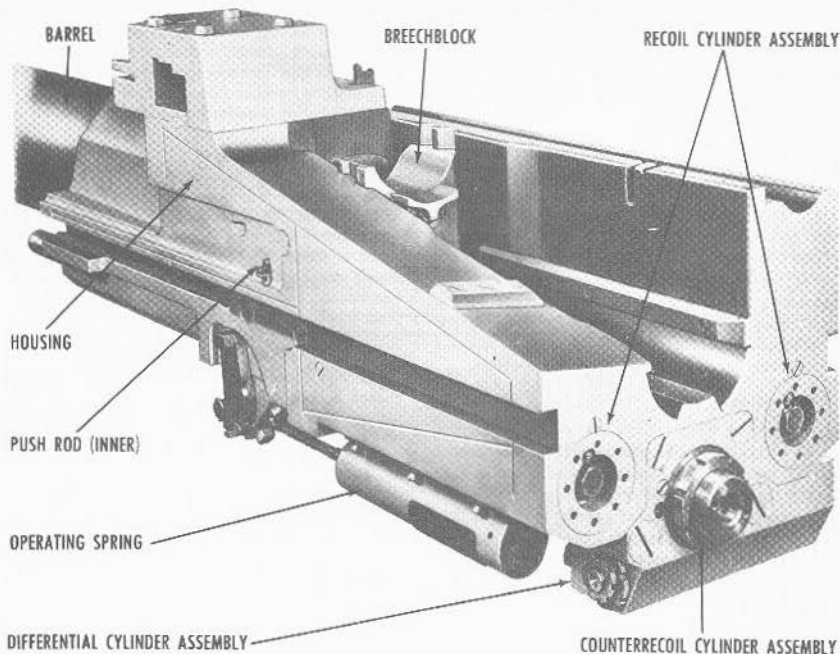

FIGURE 8B1.—5"/38 housing and gun removed from mount.

vessels. Minor variations in mechanical features reflect either improvement in design or the special requirements of certain installations. The majority of these variations are in mount design.

The gun, slide, and housing assemblies, the breech mechanism, and their associated parts are almost identical in all mounts. The greatest variation in these parts occurs in the twin mount, in which the gun emplacements form left and right gun assemblies, alike in all respects except for the reversed left and right arrangements of the two gun, slide, and housing assemblies, the breech mechanism, and their component parts. Each assembly is mounted separately in carriages on a large rectangular platform. This difference changes the appearance of the gun assembly but does not affect the mechanical operating principles.

Twin mount assemblies are installed on battleships, cruisers, carriers, and destroyers. Single mounts are found on carriers and destroyer escorts and on many

of the older cruisers and destroyers, as well as on various types of minecraft, landing craft, patrol craft, and auxiliaries.

The main purpose of this section is to describe the basic features, the function, and the mechanical operation of the 5"/38 caliber twin mount assembly. Inasmuch as the two gun assemblies are identical in operating principles, only the right assembly will be discussed, unless otherwise stated. Other types of 5"/38 mounts are discussed briefly at the end of the section.

#### 8B2. Ammunition

The gun uses semifixed ammunition consisting of a 54-pound projectile and a case assembly weighing about 28 pounds, which includes a 15-pound powder charge. The projectiles used are antiaircraft common, common, illuminating, and WP smoke. The ballistic performance obtained with a 15-pound service charge is as follows: initial velocity, 2,600 feet per

second; maximum horizontal range, 18,000 yards; maximum vertical range, 37,300 feet. The gun is capable of sustained firing at a rate well in excess of any which can be attained by the loading crew. An experienced crew can load about 15 rounds per minute for long periods, and may attain a short-period rate of 22 rounds per minute.

#### 8B3. Gun

The gun is a radially expanded monobloc barrel which weighs about 2 tons. The rifling has a uniform twist of 1 turn in 30 calibers. The bore is chromium-plated from the forward portion of the powder chamber to the muzzle. The barrel is connected to the housing by means of a bayonet-type joint and locked by a key and key-bolt seated in a keyway in the barrel. This design facilitates regunning the mount without dismantling the breech mechanism or other parts.

#### 8B4. Housing

The housing is a rectangular block-shaped forging about 5 feet long and less than 2 feet wide between its parallel side faces. Its forward portion is machined to receive the barrel. In the center is a vertical well accommodating the breechblock; and to the rear of this, aligned with the barrel bore, is a trough-like ammunition-loading tray. Three bores in the after end of the housing and parallel to the gun bore axis provide twin recoil cylinders and a single counterrecoil cylinder.

Each side face of the housing has a fore-and-aft slot forming the bearing surface for the slide guide rails.

The housing assembly supports the gun in the slide, prevents the gun from rotating, and moves on the slide guides during recoil and counterrecoil.

Other housing attachments and their operations are discussed later in this section.

#### 8B5. Slide

The slide, shown in figure 8B2 is a large box-shaped structure within which the housing moves in recoil and counterrecoil. It is open at the top and bottom, and closed at the rear by a removable plate. The rear plate forms a seat for the support-bar housing of the countercoil mechanism. The top center of the rear plate provides a mounting surface for the case tray and guide plate. The front plate has a circular opening for the gun, a gun support bearing, and openings for the piston rods. The gun housing is supported and guided by two guide rails bolted to the inner side plates. The elevating arc, gun-port shield, and rammer mechanism are secured to the slide. The slide assembly is supported in the carriage by integral trunnions on roller bearings.

The slide encloses and supports the housing and its assemblies during recoil and counterrecoil, and provides a method of elevating and depressing the gun.

Except for the rammer, the single mount slide illustrated in figure 8B2 is similar to the right-hand gun slide in the twin mount.

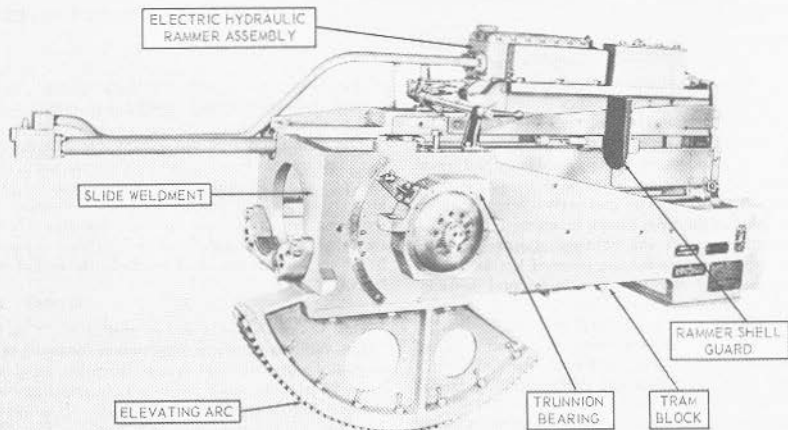

FIGURE 8B2.—5"/38 slide (single mount type).

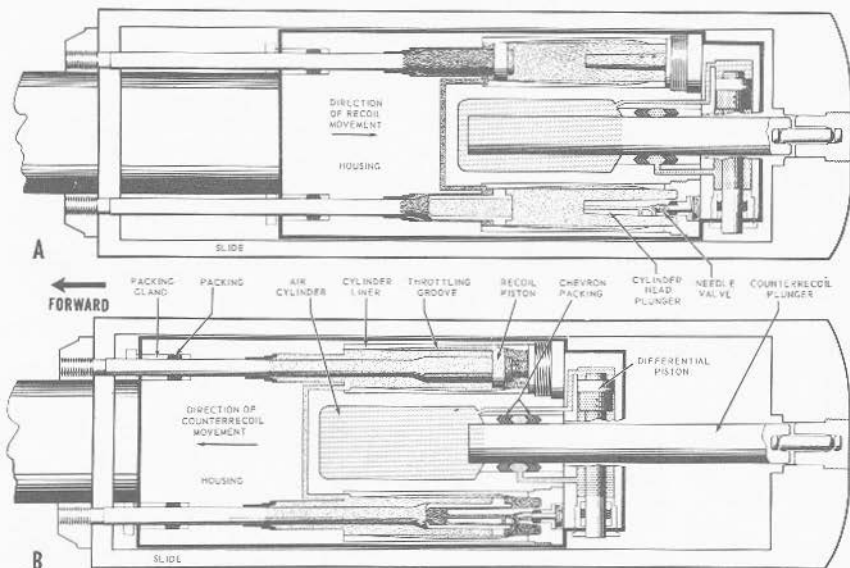

FIGURE 8B3.—5''/38 recoil mechanism. Above: In battery. Below: In recoil position.

### 8B6. Recoil system

The recoil system (fig. 8B3) utilizes pistons working in twin hydraulic cylinders to absorb the major shock of recoil, and to provide a buffer for counterrecoil, cushioning its return to battery.

The piston rods, which are integral with their pistons, extend forward from the hydraulic cylinders through the housing (through a series of bronze sleeves and packing glands), and are secured to the gun slide by piston rod yokes and nuts. Therefore, the pistons and rods remain stationary in recoil and counterrecoil while the cylinders move. The after ends of the pistons are open and hollow to admit the buffer plungers.

The twin recoil cylinders are formed by two longitudinal bores in the housing parallel to the gun axis. Into these bores are fitted bronze sleeves or liners about 18 inches long, having in their inner surfaces three equally spaced grooves of variable depth. As explained in chapter 5, these grooves control and throttle the amount of hydraulic fluid passing from one side of the piston to the other, and so insure the proper rate of recoil brake action. Pressure in both cylinders is kept equal by a pressure equalizing line.

The cylinder heads closing the after end of the cylin-

der serve as combination cylinder heads, buffer plungers, and seats for adjusting valves. As the gun is returned to battery in counterrecoil, the buffer plungers enter the open pistons and produce a dashpot effect. Escape of fluid through each plunger during this action is controlled by a needle valve (adjusting valve) which alters the size of the opening in the plunger through which the fluid is passing. Thus the valves control the rate at which the gun returns to battery at the end of counterrecoil, and the smoothness with which its forward motion stops. These valves are usually set before the gun is installed on a ship.

### 8B7. Counterrecoil system

The counterrecoil system is a hydropneumatic type of recuperator. The cylinder is formed by a bore in the after part of the housing, below the loading tray and parallel to the gun axis. The counterrecoil plunger, a highly polished, hollow cylinder about 2 feet long and  $3\frac{1}{2}$  inches in diameter, extends out of the after end of the air cylinder through a chevron packing and packing gland. It is coupled to the rear plate of the slide by the support block, support bar, and support bar housing. See figure 8B4. This

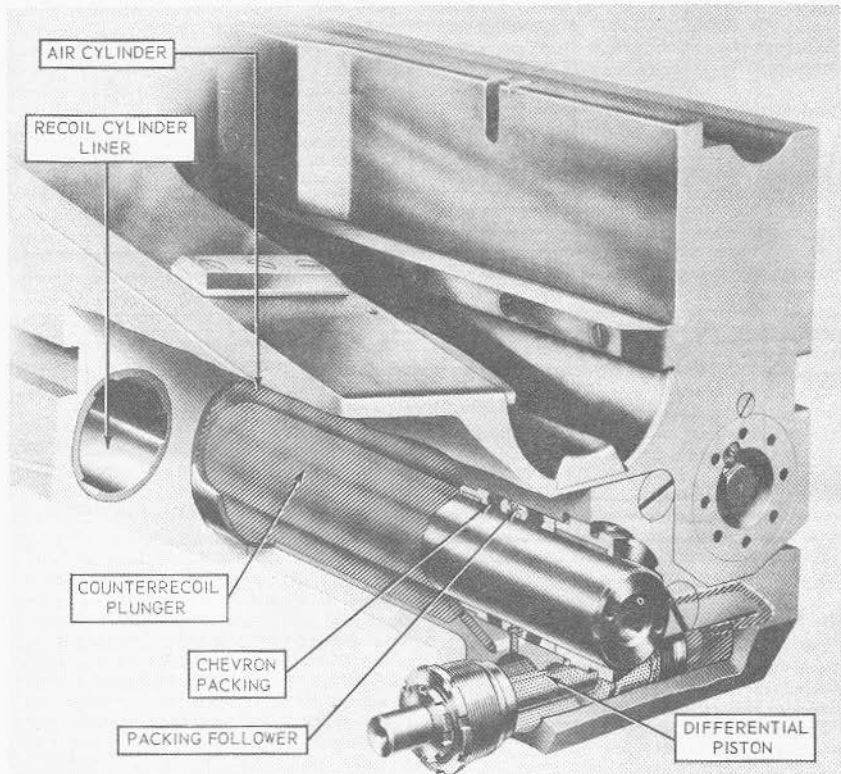

FIGURE 8B4.—5 1/8 counterrecoil system. Run in full recoil position.

coupling arrangement is not rigid, but is designed to permit enough freedom of motion so that the counterrecoil plunger can align itself with the packing gland, thus preventing distortion of the packing and consequent air leakage through the packing gland.

When the gun is in battery, normal pressure in the air cylinder is kept at 1,450–1,550 psi. Recoil compresses the air further and the pressure rises to approximately 2,250 psi.

Fluid under pressure is forced to the chevron packing from the differential cylinder through drillings in the air cylinder forging. See figure 8B4.

As the barrel and housing move aft in recoil, the

recoil pistons and piston rods are held stationary by the slide while the recoil cylinders move with the housing. Recoil fluid is forced past the pistons through the variable depth grooves, and the movement of the recoiling parts is retarded and finally stopped.

Assisting this brake action of the recoil system is the action of the recuperator. As the air cylinder moves aft over the stationary counterrecoil plunger, the air pressure in the cylinder is increased.

When the rearward action of the recoiling parts has been stopped, the highly compressed air within the recuperator main cylinder drives the cylinder and

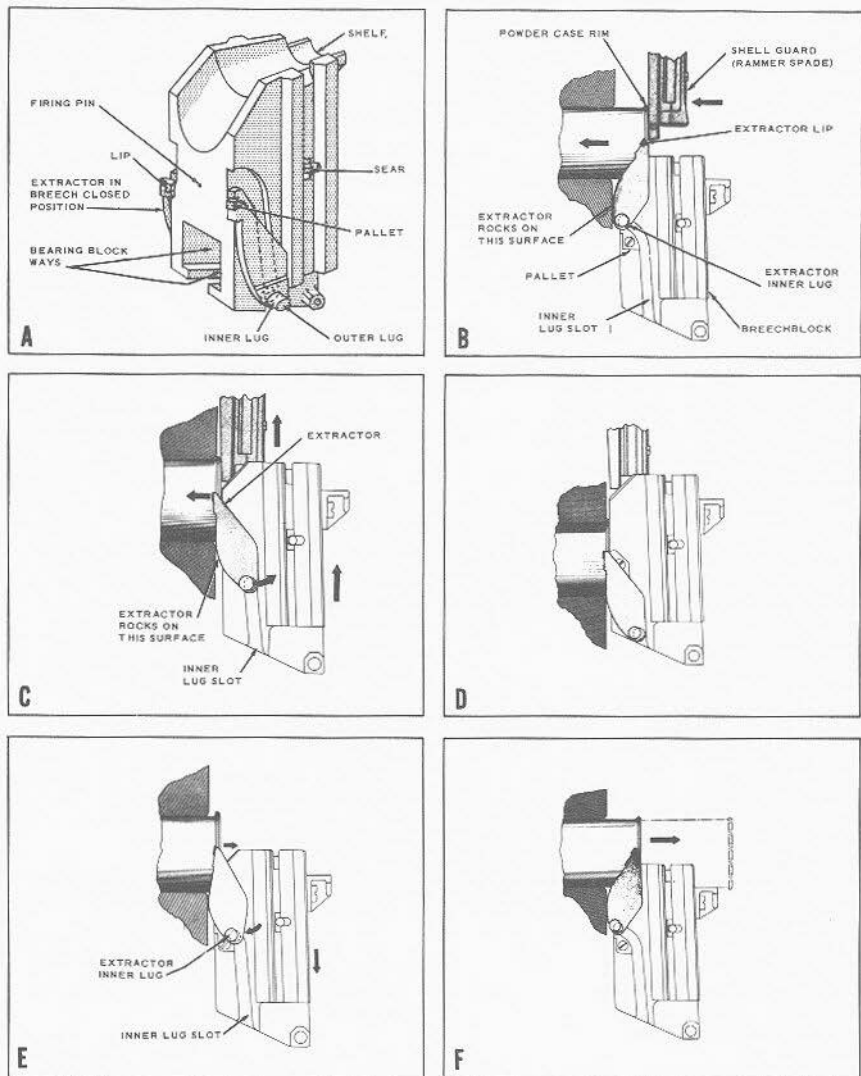

FIGURE 8B5.—5''/38 breechblock. A. Main parts. B, C, D, E, F. Steps in functioning.

gun housing forward. The first 6 inches of this counterrecoil motion is retarded only by the recoil fluid as it is displaced past the recoil piston. Then the plungers of the recoil cylinder heads enter the open ends of the recoil pistons and produce their dashpot effect (as explained in chapter 5), as controlled by the needle valves.

When the gun is not in use, the housing is secured to the slide by a metal *safety link*. (It should always be disconnected before firing, but neither gun nor mount will be damaged if this is not done.)

### 8B8. Breechblock

The breechblock (fig. 8B5) is a vertical sliding wedge which fits into a rectangular well cut through the center of the housing from top to bottom. Ribs on the left and right sides of the block match grooves in the breechblock guides of the housing and guide the block as it moves up and down to close or open the breech. They also function to transmit the recoil shock from the breechblock to the housing. The upper portion of the forward face of the block is beveled, and the breechblock guides slant forward slightly from bottom to top. The result is twofold. As the block rises it also moves slightly forward to wedge the cartridge case home, while the beveled forward face assists the wedging action. A bore penetrating the block from rear to face contains the firing mechanism. Additional bores house the sear, sear safety latch, retracting lever bearing blocks, and operating shaft central arm. Slots or grooves machined in the right and left sides of the block serve as camways for the extractor inner lugs. These slots are fitted at the upper end with pallets—shoulders against which the inner lugs bear when the block has been dropped.

### 8B9. Extractors

Extraction of the empty cartridge case is a mechanical operation accomplished by the extractors as the breechblock is lowered during counterrecoil. The two extractors are rocker arms, each with inner and outer lugs projecting from the opposing flat surfaces at its base. The outer lugs ride in kidney-shaped slots in the breechblock guides of the housing. In these slots the lugs can move in a fore-and-aft direction, but not up and down.

The extractors also have eccentric inner lugs which fit into slots machined in each side of the breechblock. As the block drops, these inner lugs ride in their slots and are forced forward by the curved portion. Since the extractors are rocker arms rocking on the breechface, the upper portion of each extractor is forced aft

when the inner lugs are forced forward. The lips on the extractors engage the rim of the cartridge case. The quick forward motion of the lower end of the extractors causes an accelerated flip of the extractor lips to the rear, thus extracting the case (fig. 8B5). Spring-loaded extractor plungers (fig. 8B6) push forward against the outer lugs and assist in extraction.

The breechblock is held down against the action of the operating spring by the inner lugs bearing on the pallets. (See fig. 8B5.) When the block is in its lowest position, the extractor inner lugs are in the curved portion of their slots and are held there by the extractor plungers, which are pushing forward on the outer lugs. The lower surfaces of the lugs and the upper surfaces of the pallets are flattened to provide good bearing surfaces.

The breech cannot be closed as long as the lugs bear on the pallets. However, when the gun is loaded, the rim of the case strikes the extractor lips and forces them forward. (See fig. 8B5.) The extractor rocker action moves the inner lugs aft against the action of the extractor plunger springs, until they clear the pallets and are in the vertical portion of the slots. The operating spring can then force the breechblock upward to close the breech.

### 8B10. Operating shaft

The vertical motion of the breechblock is controlled by the operating shaft (fig. 8B7), which rotates in bearing caps on the bottom of the housing. The operating shaft is rotated automatically by cam action during the firing cycle, or manually by movement of the hand-operating lever.

The operating shaft has cranks on both ends. A lug extends out from the operating-shaft crank at the left end to engage the operating-shaft cam plate for semiautomatic operation of the breech mechanism. The crank at the right end (hand-operating crank) has a projecting lug which engages a crank of the hand-operating mechanism for manual operation. Near the left end of the shaft is a curved, cam-like arm to which the operating-spring chain is attached. In the center is the operating-shaft central arm, made up of two parallel arms, with a pin passing through both arms. The pin also passes through the curved slot of the retracting lever which operates between the arms during shaft rotation. The ends of the pin project beyond the sides of the central arm and carry the bearing blocks. These bearing blocks slide in the inclined bearing-block ways (fig. 8B5) within the bottom of the breechblock. Thus rotation of the shaft causes vertical movement of the breechblock.

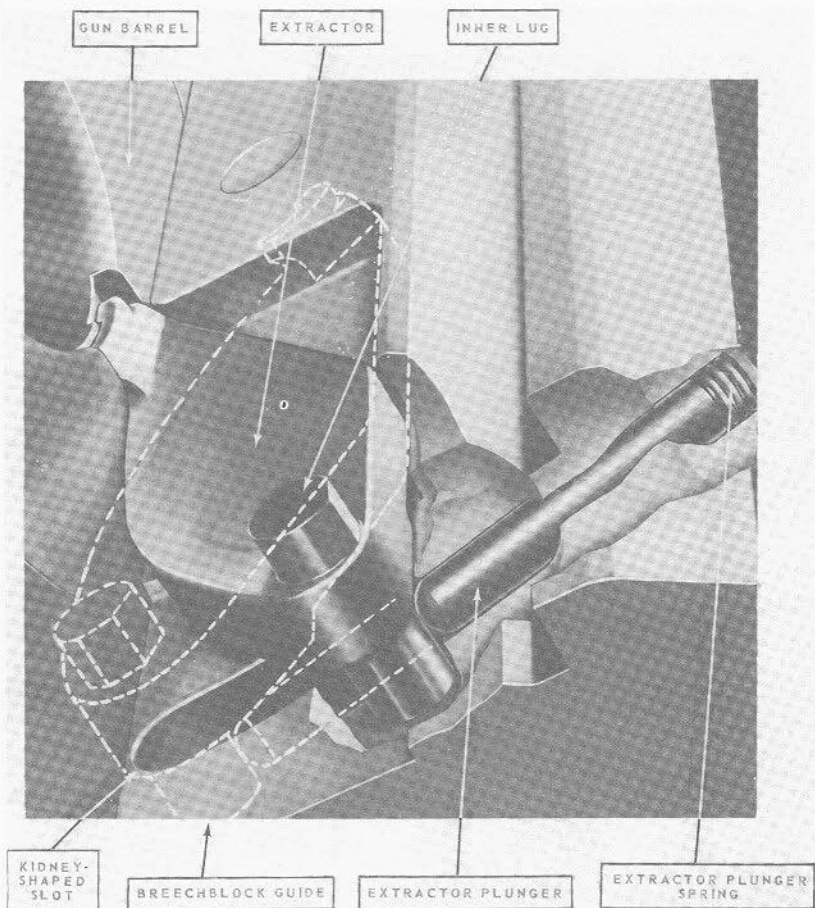

FIGURE 8B6.—Right extractor, 5"/38 gun.

**8B11. Salvo latch**

The salvo latch, shown in figure 8B8, is a positive-type latch, mounted on the left operating-shaft bearing. With the breechblock raised and the gun in bat-

tery, the latch is engaged with the latching lug on the operating-shaft crank. Engaged, it prevents the opening of the breech of an unfired gun by preventing rotation of the operating shaft unless the latch is tripped by hand. During gun recoil movement, the

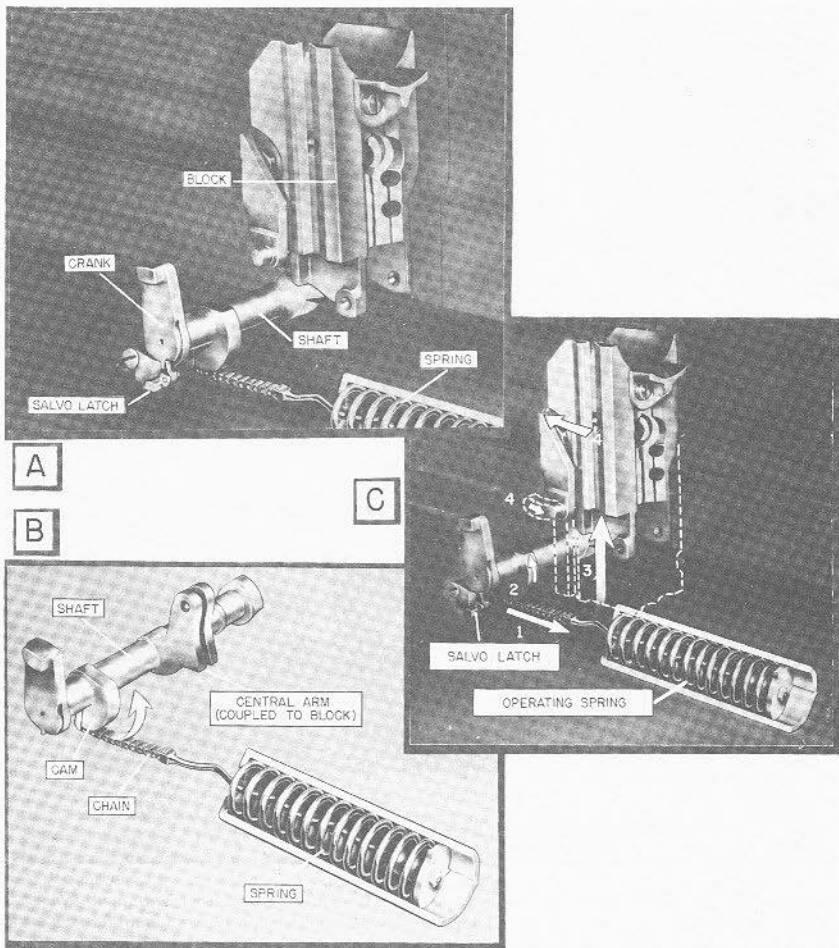

FIGURE 8B7.—Parts and functions of 5 1/8 inch/38 breech mechanism.

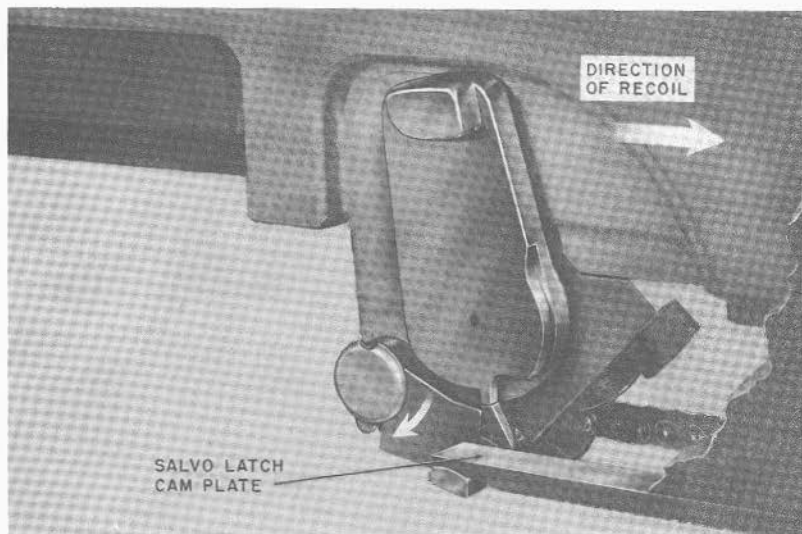
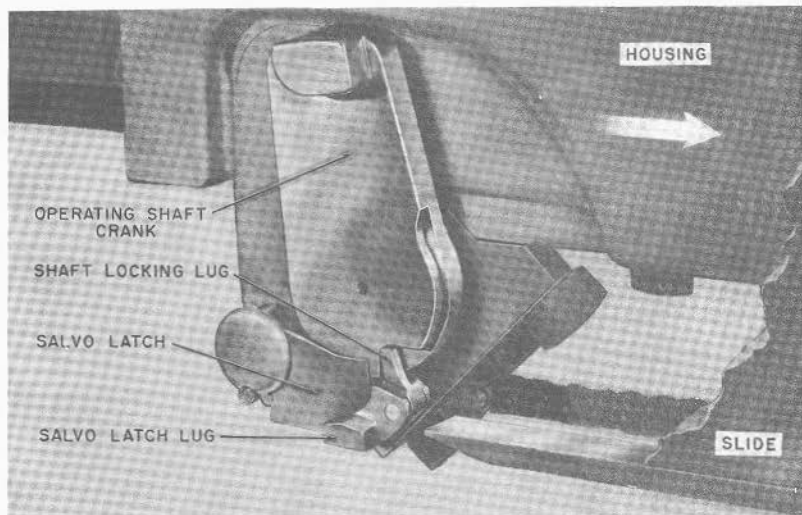

FIGURE 8B8.—5"/38 salvo latch.

latch-operating lug projecting from the salvo latch passes beneath the salvo-latch cam plate. This forces the salvo latch down, permitting the spring-loaded pawl to snap forward and retain the latch in its disengaged position by bearing against the lower surface of the latching lug. The operating-shaft crank is now free to rotate to permit opening of the breech. When the breechblock is closed again, rotation of the operating shaft causes the latching lug to rotate aft and force the salvo-latch pawl aft. This permits the salvo latch to rise under spring pressure and engage the latch lug, so that the breech is locked.

#### 8B12. Operating-spring assembly

This assembly consists of an operating chain, connecting rod, coil spring, adjusting nut, and cylindrical housing for the spring.

One end of the operating chain is attached to the operating shaft (fig. 8B7), while the other end is secured to the connecting rod. This rod passes through the coil spring and is attached to the after end of it by the adjusting nut. The housing which encloses

the spring is bolted to the lower part of the gun housing (fig. 8B7). Opening the breech compresses the spring, because the rotation of the operating shaft winds up the chain connection on the shaft, pulling on the adjusting nut on the other end of the spring. In this way the spring stores up the energy for closing the breech. The adjusting nut provides a means for varying the spring tension, which in turn regulates the force of the breech closing.

#### 8B13. Cam plate

A pivoted cam plate, mounted in the inner left face of the slide, as shown in figure 8B9, controls the rotation of the operating shaft by means of a crank arm at the left end of the shaft. During recoil, the crank pushes the cam plate outward toward the slide about the pivot pin. This movement compresses a spring placed between the cam plate and the slide. The operating shaft does not rotate at this time. At the instant the crank moves abaft the cam plate, the spring snaps the cam plate back into position.

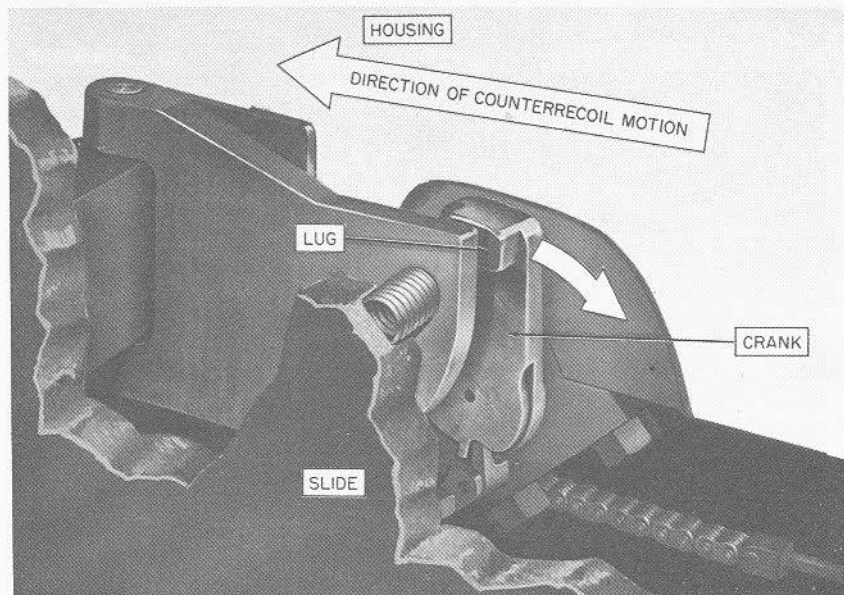

FIGURE 8B9.—5"/38 operating-shaft cam plate.

During counterrecoil, the lug on the operating-shaft crank strikes the curved portion of the cam plate and is forced downward by it. This motion of the crank rotates the operating shaft and lowers the breechblock.

The central inboard section of the cam plate tapers down to a wedge-shaped groove which is opposite the position of the lug on the crank when the gun is in battery and the breechblock is open. This groove permits the crank to rise as the breechblock closes.

A movable cam-plate retractor, has a cam surface which positions the cam plate against the slide so that the cam plate will be inoperative. The breechblock must then be lowered by a handcrank. The cam-plate retractor can be moved forward to the position designated by symbol S (single) for manual operation or pulled rearward to the position designated by symbol A (automatic) for semi-automatic operation, in which the cam plate will open the breech during counter-recoil.

#### 8B14. Hand operating lever

Since the hand operating lever on the 5"/38 caliber gun is not a recoiling part, it is necessary to provide a mechanical linkage which acts to engage the operating shaft when the gun is in battery and still permits the shaft to move freely in recoil. The linkage is mounted and pivoted on the right outside face of the slide, as shown in figure 8B10.

The hand operating lever is linked to a latch bell crank which projects in from the side of the slide. With the gun in battery, the latch bell crank contacts the hand-operating crank at the right end of the breech-operating shaft in such a way that rotation of the latch bell crank (in a counterclockwise direction by the hand-operating lever) will cause rotation of the breech-operating shaft and the lowering of the breechblock.

The hand-closing latch is provided to permit manual closing of the breech during action in case there is a failure in the breech-operating spring or connecting rod.

#### 8B15. Firing mechanism

The firing mechanism provides for percussion and electrical firing. Electrical firing requires that the firing pin be insulated from the gun, but be in contact with the primer when the breechblock is closed. Percussion firing with the pin resting on the primer is obtained by striking the pin with a plunger. The arrangement of the firing mechanism in the cocked position is shown in figure 8B11, part A.

The *retracting lever* is pivoted in the *breechblock extensions*. The vertical arm of the retracting lever engages a flange on the *firing-pin unit*. A pin carried

in the operating-shaft central arm passes through the slot in the lower arm of the retracting lever. When the breechblock crank rotates to lower the breechblock, the pin rides in the slot and forces the retracting lever to rotate and cock the firing-pin unit. It is to be noted that cocking is accomplished when the block drops.

The firing-pin unit, shown in figure 8B11, part A, is held in the breechblock by the mechanism lock. In the fired (uncocked) position, the *firing plunger* rests against the shoulder on the *firing pin*. During cocking, the retracting lever pulls the *cocking handle* and firing pin aft, thereby drawing the firing plunger to the rear and compressing the firing spring. The *cocking sleeve*, attached to the plunger, moves aft until the cocking-sleeve lug just passes the *sear shoulder*. At the same time, the *contact spring* is compressed.

As the breechblock closes, the retracting lever allows the contact spring to move the firing pin forward until it gently but firmly contacts the primer *after* the block is fully closed. During the movement of the firing pin, the sear shoulder engages the cocking-sleeve lug, holding the cocking sleeve and firing plunger in the cocked position. As the breechblock finishes closing, the central arm of the operating shaft raises the sear safety latch, disengaging its lug from the groove in the sear. The pin is then in position to pass the current for electrical firing, and ready to transmit the blow of the firing plunger for percussion firing (part A of fig. 8B11).

Percussion firing is initiated by the pointer, who presses a foot treadle. Through a system of linkages and push rods (discussed in the next article), the sear is pushed inward against its spring. This releases the cocking-sleeve lug through the sear notch. The firing spring drives the cocking sleeve and firing plunger forward, and the blow of the plunger drives the firing pin into the primer, thus firing the gun.

The gun cannot be fired until the breech is *fully* closed, because until then, (1) the firing pin does not touch the primer, (2) the sear is locked by the *sear safety latch*, and (3) the sear is out of alignment with the *inner push rod* of the foot firing linkage.

#### 8B16. Foot-firing linkage and firing stop mechanism

The foot-firing mechanisms of both guns are operated by a foot treadle mounted on the outboard side of the left carriage. They are controlled by the pointer's right foot when it is desired to fire the guns by percussion. As the pointer depresses the treadle, its action is transmitted through a system of cranks and levers to the outer push rod located in the slide. See part B of

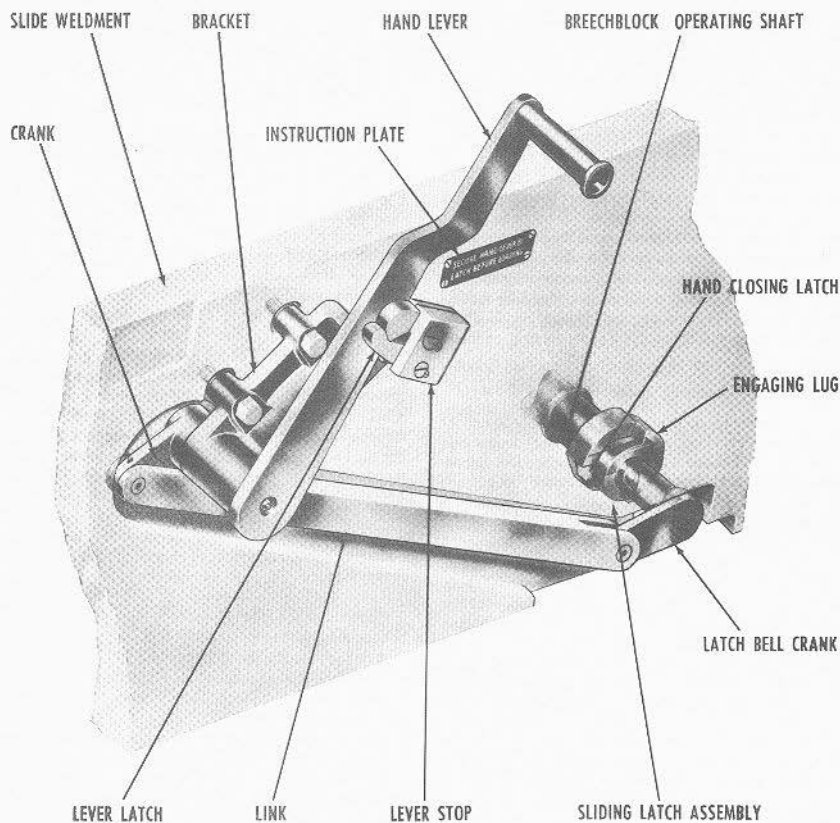

FIGURE 8B10.—5"/38 hand-operating mechanism.

figure 8B11. Movement of this push rod pivots the trip plate inward. This moves the inner push rod (in the housing) inward. The end of this rod is in contact with the sear when the breech is fully closed. Movement of the inner push rod displaces the sear, and the gun fires.

To ensure that the firing rod can be rotated only when the gun is not pointed into own ship, a *firing stop mechanism* is used. The principles of this mechanism were explained in chapter 5, and the mechanism as it is installed on 5-inch mounts is shown in figure 8B11,

part B. It functions to interrupt fire both by percussion and electrically, whenever the axis of the bore is aligned with some part of the ship's structure.

A spring-loaded plunger that bears against a circular cam plate permits fire when it is in contact with a recessed part of the cam plate surface, and stops fire when in contact with a raised part of the cam plate surface. The pattern to which the cam is cut is plotted individually for each gun mount.

As the gun is elevated, the plunger is positioned vertically by the elevation input rod and rack. As the

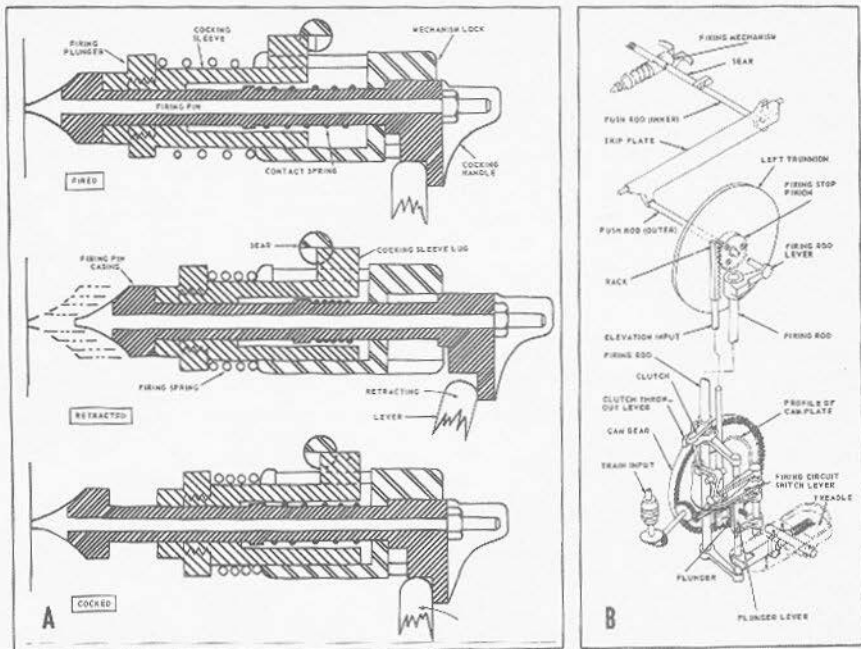

FIGURE 8B11.—5"/38 firing system. A. Firing mechanism. B. Foot-firing linkage and firing stop mechanism.

mount is trained, the profile cam is rotated by the bevel gears and pinion to correspond with the position of the mount. Thus the position at which the plunger strikes the profile cam will be determined by the elevation and train of the gun.

If the plunger rides on a portion of the cam which is not recessed, the clutch throw-out lever and clutch lever do not contact each other. The pointer pressing the treadle does *not* move the firing rod, and he cannot fire the gun. If, on the other hand, the plunger rides on a recessed portion of the profile cam, the bell crank will move the linkage so that the clutch throw-out lever and clutch lever are in contact, and motion of the pointer's foot on the treadle will be transmitted to the firing rod, and thus the gun will be fired. The profile cam must be so cut that when it is positioned by an angle of elevation and train of the gun which would damage own ship, the plunger will strike a nonrecessed surface of the cam.

The movement of the plunger is also transmitted to

a switch in the electric firing circuit when the plunger rides out of the recessed surface of the profile cam.

### 8B17. Gas ejector system

Gas ejectors function to prevent the entry of powder gases into gun mounts, to safeguard against the danger of flarebacks, and to assist in maintaining a rapid rate of fire by clearing the bore of gases. Air under pressure of approximately 75 psi is piped to the gun mount from the ship's supply. It moves through tubing and air passages bored in the gun housing to nozzles located in the breechblock guideways and pointed toward the gun bore. During counterrecoil of the gun, a gas ejector valve, located in the forward and top of the housing is cammed open and the gas ejection action begins. The valve is tripped and closed by action of the rammer operating shaft as the next round is rammed. A hand lever permits manual opening and closing of the valve.

**8B18. Gun operating cycle**

When the gun is fired, the following cycle of operation takes place.

The force of the expanding gases causes the barrel and housing assemblies to move rearward in recoil within the slide. During the first part of recoil, the salvo latch is disengaged and the operating shaft is then free to rotate. The braking or retarding action of the recoil and counterrecoil systems stops the rearward action, and the recuperator moves the recoiling parts forward again. This forward movement, in turn, is checked and smoothed by the dashpot and buffing action within the recoil cylinder.

During counterrecoil the operating shaft is rotated upon contact with its cam plate. This rotation drops the breechblock, retracts the firing pin, sets the sear, and compresses the operating spring. As the breech opens, the outer lugs of the extractors are thrust forward by their plungers while the inner lugs are moved forward by their slotted camways in the breechblock. The lips of the extractors snap to the rear, extracting the empty case, and the inner lugs come to rest on the pallets, holding the breechblock down against the pressure of the operating spring. During the initial

movement in counterrecoil, the gas ejector valve is tripped to open position.

When the next round is rammed, the cartridge case trips the extractors, rocking the inner lugs off the pallets. The gas-ejector valve is tripped to close by rotation of the rammer-operating shaft. The block rises, wedging the cartridge case, moving the retracting lever to permit the firing pin to contact the primer, and bringing the sear in line with the inner push rod of the foot firing mechanism. Simultaneously, as the operating shaft rotates, the latching lug on the shaft picks up the salvo-latch pawl and enables the salvo latch to lock the breech. The gun is now ready to fire the next round.

**8B19. Rammer mechanism**

The rammer assembly is a semiautomatic, electric-hydraulic unit mounted at one side of the loading tray on the upper rear portion of the slide. It is designed to function properly at any gun elevation.

The power unit consists of a 7½-hp electric motor which drives a hydraulic pump mounted in the oil supply tank.

The rammer itself (fig. 8B12) includes:

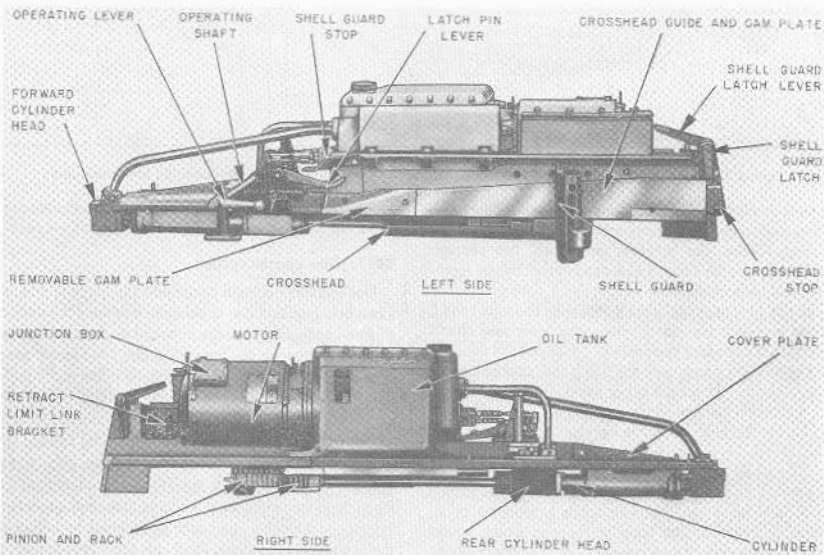

FIGURE 8B12.—5"/38 rammer, assembled arrangement.

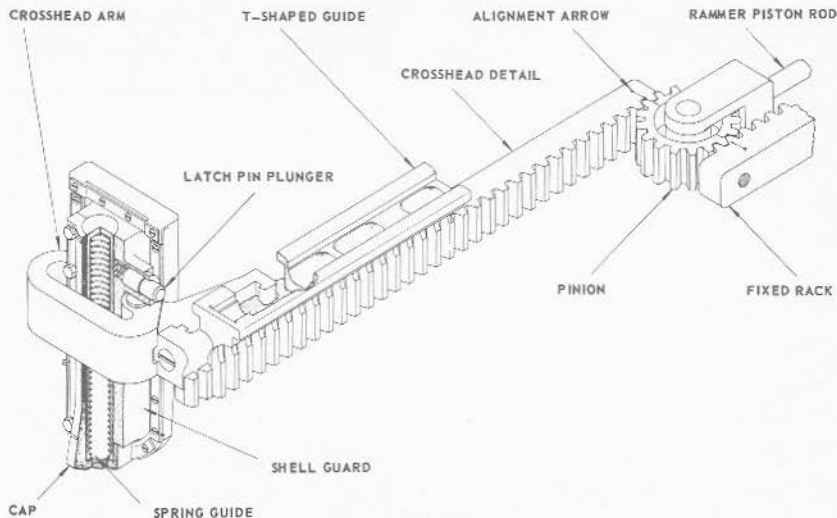

FIGURE 8B13.—5"/38 rammer pinion and rack arrangement.

1. a hydraulic cylinder
2. a piston and piston rod
3. a pinion secured to the after end of the piston rod by a yoke
4. a fixed rack (fig. 8B13) secured to the inner face of the slide
5. a crosshead, consisting of a crosshead detail (movable rack), a crosshead arm, and a shell guard or spade
6. control valves and operating levers

In open mounts the rack-and-pinion arrangement (No. 5) is omitted. The crosshead drives the spade direct.

The hydraulic pump introduces oil under pressure into the cylinder to drive the piston forward for ramming and aft for retracting. This motion is transmitted to the crosshead through the pinion which is meshed with both the fixed rack and the crosshead detail (movable rack). The rammer piston pulls the pinion forward about 26½ inches, forcing it to rotate between the two racks so that the crosshead is translated a distance equal to twice the linear travel of the pinion. This pinion arrangement permits the use of a shorter cylinder which can be completely enclosed within the shield.

The spade rams the projectile and case into the chamber at the same time. The face of the spade is

padded with rubber and backed with canvas to prevent damage to the base of the case during the ramming operation. The spade is mounted on the crosshead in such a manner that it can be moved upward about 5 inches against the action of a vertical spring placed between spade and crosshead. A spring-loaded plunger (plunger latch) projects from the inboard side of the spade.

The *crosshead guide and cam plate* is mounted along one side of the loading tray. Its purpose is to guide and support the crosshead, and to provide cam surfaces upon which the plunger latch rides and hence controls the vertical motion of the spade. After a round is rammed, the breechblock rises and forces the spade upward about 3 inches. After the gun is fired, as the spade and crosshead move aft in retraction, the plunger latch rides up an inclined cam surface on the cam plate and the spade is raised an additional 2 inches. The upward movement of the spade, totaling about 5 inches, is sufficient to permit the ejected case to pass under the spade.

A projection on the forward left side of the crosshead engages with a rammer interlock mechanism at the end of the ram stroke, latching the crosshead to the housing. The interlock mechanism is a spring-loaded catch partly enclosed in the safety-link bracket. The crosshead is unlatched by relative motion between

housing and slide during the first part of recoil as the rammer interlock is forced to the left by the unlatching cam on the cam plate. A lever is attached to permit manual release.

Control valves, operated partly by hand and partly automatically through a control shaft and linkage, mounted as in figure 8B14, control the motion of the piston. Movement of the control shaft and linkage positions hydraulic valves which cause the piston to ram, retract, or remain at neutral. An operator can control the rammer at any point in the cycle by moving the control lever.

Near the end of the retract stroke, the crosshead engages a retract-control rod connected to the control valves by a linkage. When the rammer forces the retract-control rod a short distance aft, the linkage and valves are returned to neutral position and retraction is stopped.

When a round is rammed and the breechblock rises, forcing the spade upward, the spade plunger latch actuates the latch-pin lever. The latch-pin lever is connected to the control mechanism so that upward movement of the lever positions the control valve to neutral, releasing the ram pressure.

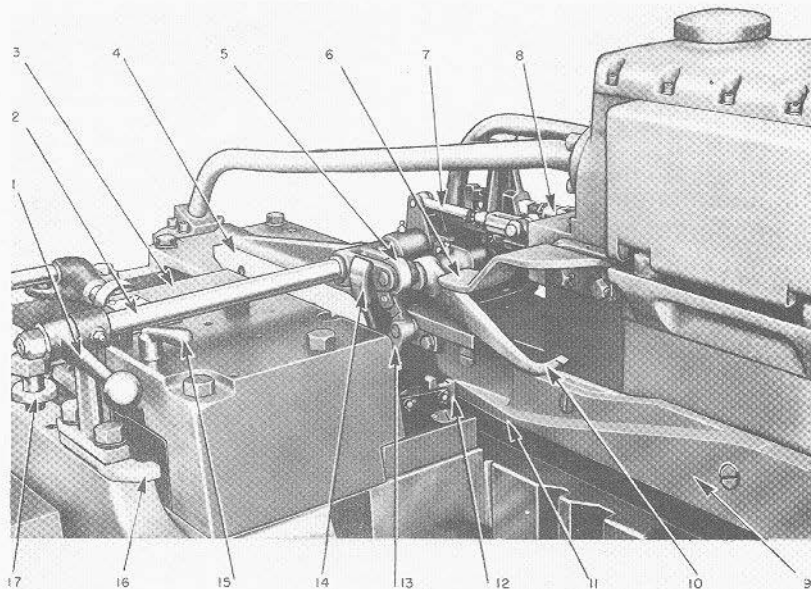

## LEGEND

- |                               |   |
|-------------------------------|---|
| 1 - OPERATING LEVER           | 10 - LATCH PIN LEVER                          |
| 2 - OPERATING SHAFT           | 11 - RAMMER INTERLOCK CAM SURFACE             |
| 3 - SAFETY LINK BRACKET       | 12 - RAMMER INTERLOCK                         |
| 4 - RETRACTION CAM            | 13 - GAS EJECTOR INTERMEDIATE LEVER           |
| 5 - RETRACTION CAM FOLLOWER   | 14 - RAMMER INTERLOCK MANUAL<br>RELEASE LEVER |
| 6 - SHELL GUARD STOP          | 15 - GAS EJECTOR HAND LEVER                   |
| 7 - AUTOMATIC PILOT VALVE ROD | 16 - GAS EJECTOR TRIP PLATE                   |
| 8 - OPERATING VALVE PUSH ROD  | 17 - SAFETY LINK (STOWED POSITION)            |

FIGURE 8B14.—5"/38 mount rammer controls.

Automatic retraction of the rammer is accomplished by means of a cam follower attached to the control shaft which rides over the cam mounted on the upper part of the housing. The retraction cam moves rearward during recoil of the gun, operating the cam follower which rotates the control shaft to the retract position.

### 8820. Ramming cycle

Assume that the cartridge case and projectile have been placed in the loading tray and that the spade is behind the case in position for ramming. The projectile man throws the hand control lever into the RAM position; the spade moves forward, forcing the ammunition into the gun; and the crosshead is locked to the housing by the crosshead interlock latch. (Fig. 8B14.) When the rim of the cartridge case strikes the extractors, the breechblock rises and forces the spade upward. As the spade rises, the plunger latch forces the latch-pin lever upward. This action returns the control valve to the neutral position.

After the gun is fired, the following actions take place during the first part of recoil: (1) The crosshead rides back with the recoiling gun and housing; (2) the crosshead unlatching cam pushes against the crosshead interlock, latch, releasing the crosshead; and (3) the rammer control shaft is positioned for retraction by the retraction cam, and the rammer continues to retract under its own power.

During retraction, the plunger latch rides on the inclined cam surface on the cam plate, and the spade is raised to provide the necessary clearance for the ejected case. Near the end of the retract stroke, the crosshead engages the retract-control rod. When the rammer forces the retract-control rod a short distance aft, the control valves are returned to the neutral position and retraction is stopped. The spade is held in its upper position by a latch which must be released manually by means of the spade-release lever before the spade can drop into position to start another ramming cycle.

There are two inclined cam surfaces on the forward part of the crosshead guide and cam plate which are not used in ordinary operation. The plunger latch is raised above these surfaces by the rising breechblock, and rides past them during recoil, directly to the crosshead guide and cam plate. The lower of the two cam surfaces is used when exercising the rammer with the breech mechanism idle and the breech open. Then the spade is not raised by the breechblock, but is raised by the latch riding the lower cam surface. The upper cam surface is included in the design as a precautionary measure. If the ram stroke is started with the spade in its *up* position, the spade plunger latch will

ride the upper cam surface. This prevents damage, should the breechblock be closed.

### 8B21. Loading operation

Assume that the gun crew has been firing. After the ejected case has cleared the loading tray, the *gun captain* depresses the *spade release lever* to drop the spade.

The *powder man* takes a powder case out of the powder hoist, removes the primer-protecting cap, and places the case on the loading tray. The *projectile man* removes a projectile from the projectile hoist and places it on the loading tray just forward of the case. The projectile man then pulls the rammer lever to RAM, and the charge is rammed home. After the gun fires, the hot case is ejected through the case ejection chute for angles of fire up to 40°. For higher angles of fire, the hot case must be removed manually by the hot-case man.

### 8B22. Carriage, stand, and roller path

The general arrangement of these parts is shown in figure 8B15.

The carriage is an assembly of the base-ring type. The right and left gun carriages are secured to the four fore-and-aft girders which are supported by the base ring. The base ring supports the twin guns, their elevating and training drives, hoists, sights, shield, and other parts of the rotating assembly. The upper roller path is fitted into the base ring.

The stand is a large, circular steel casting with a flange at the bottom around the outer circumference for bolting to the gun foundation. It is designed to accommodate the training circle and lower roller path.

The upper roller path furnishes a bearing surface for the horizontal rollers and the radial rollers. A radial bearing surface secured to the inner vertical surface of the stand serves as the other bearing surface of the radial bearings. The horizontal rollers bear on the lower path, permitting the mount to rotate. Bronze separators support and separate the rollers.

Secured to the base ring are four holding-down clips, designed to fit under the training circle with a small amount of clearance. They serve to steady the mount during rotation and firing, and to hold the mount to the roller path.

### 8B23. Training and elevating gear

These assemblies, illustrated in figure 8B16, are electric-hydraulic power drives of similar type in arrangement, operation, and control, but different in size and capacity. The training gear is driven by a 40-horsepower motor and the elevating gear by a 10-

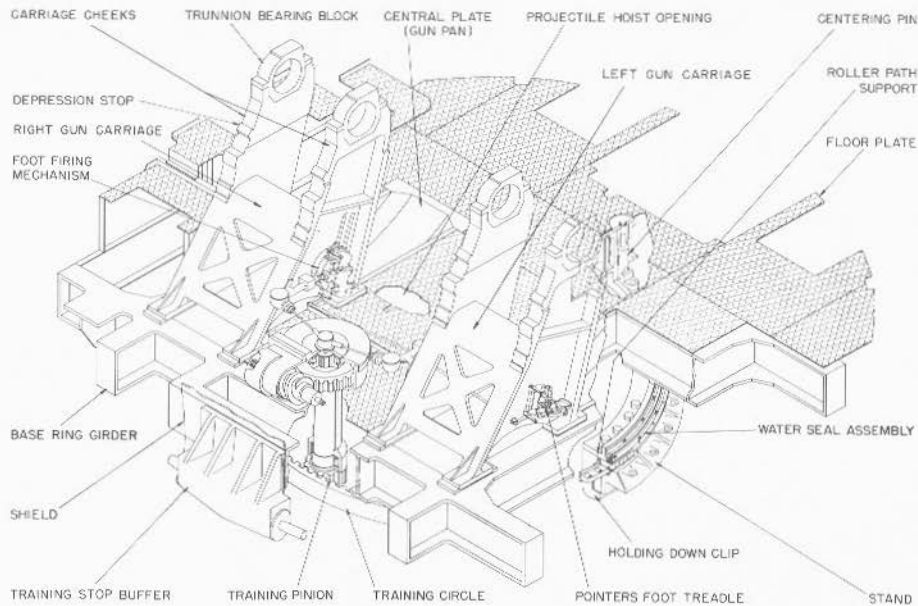

FIGURE 8B15.—5<sup>1</sup>/<sub>8</sub> twin-mount stand and carriage.

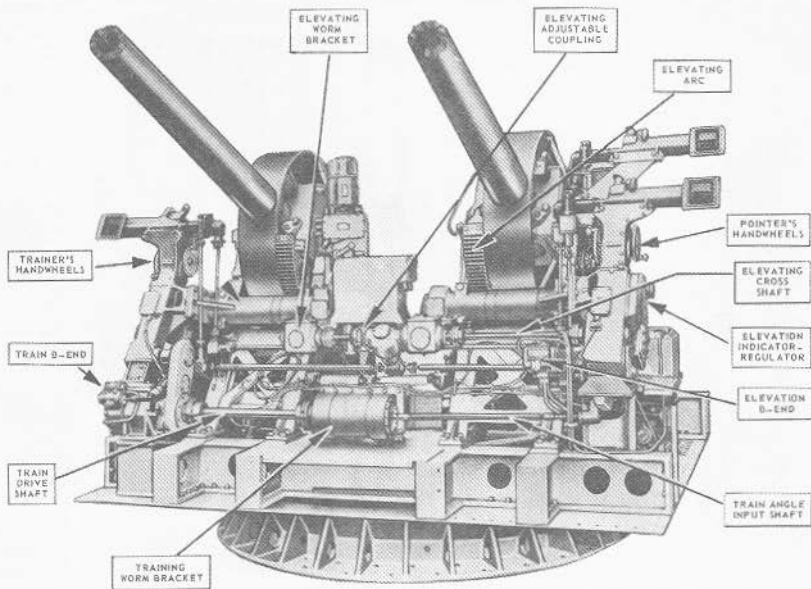

FIGURE 8B16.—5"/38 twin-mount elevating and training gear.

horsepower motor. Each has its own hydraulic transmission unit.

Each transmission unit consists of a hydraulic pump connected by pressure lines to a hydraulic motor. The output of the pump to the motor is controlled by an indicator-regulator or by a control unit. Through each transmission unit, the constant-speed, unidirectional input from the electric motor is converted into a reversible, variable-speed output to the respective elevating arcs or training rack. Further discussion of automatic control equipment is found in chapter 10.

Both pointer and trainer have two shift levers available. One of these is a *speed selector*, which permits a selection of either high speed or low speed operation. The other lever provides a choice of 4 methods of *gun movement control*, 3 of which employ power drive while the fourth is a manual operation. The 4 methods of gun movement control are as follows:

1. *Automatic.* This is remote director control of the hydraulic pump by electrical signals transmitted to the indicator-regulators of the elevating or training assemblies. The speed selector lever must be in the **HIGH SPEED** position if automatic control is selected.

2. *Local.* In this mode, rotation of the pointer's or trainer's handwheel positions a servo device which in turn positions an A-end tilt box of the appropriate drive. This type of control, then, is similar to automatic, except that rotation of the handwheels takes the place of the electrical signals from the remote point. Either high or low speed may be selected.

3. *Hand.* This is power drive control using the handwheels with their shafts and gears to position the A-end tilt box without the intermediate use of the servo mechanism. Either high or low speed may be selected.

4. *Manual.* This is manual drive of the gun movement, with the handwheels geared directly to the training rack or elevating arc. The hydraulic transmission and the power drive are bypassed and hence inoperative. Normally, only low speed is employed in manual.

The selector levers of the pointer and trainer operate independently, so that a different gun movement control or speed may be employed in train from the control or speed in use in elevation.

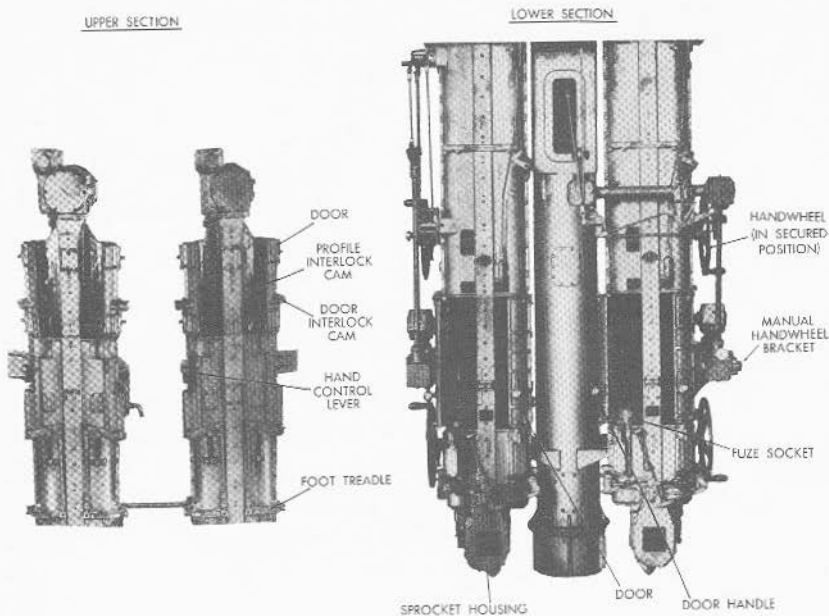

FIGURE 8B17.—5''/38 projectile hoist.

#### 8B24. Projectile hoists

The twin mount is equipped with right and left hoists of similar design. They are semi-automatic endless-chain, enclosed, dual-tube hoists with electric-hydraulic drive. An auxiliary manual drive is provided for emergency use. Figure 8B17 shows the upper end of the hoists in the gun mount and the lower end in the handling room. Each hoist is separately driven and controlled, but an indicator-regulator simultaneously adjusts fuze settings for both hoists through shafts and gears.

The hoist drive consists of a 10-hp electric motor, a hydraulic pump enclosed in a tank, a motor unit, and a control unit. The hydraulic pump is connected to the hydraulic motor by pressure lines.

The hydraulic motor is geared to a chain-driving sprocket in the upper end of the hoist. A lower idler sprocket is enclosed in the lower sprocket housing. An endless *power chain* or *hoist chain* is held between the two sprockets as shown in figure 8B18. On either

side of the power chain are *fuze-setting drive chains*. These will be discussed later.

Two projectile flights (fuze sockets) are attached to the power chain of each hoist. The flights are so placed that 1 is at the upper end of 1 tube when the other is at the lower end of the opposite tube. The upper and lower position of the flights are the limiting points of chain movement.

The control gear shown in figure 8B19 consists of a system of linkages from the top and the bottom of the hoist to the hydraulic control unit. At the bottom of the hoist, a control cam protrudes into each hoisting tube. A projectile placed in one of these tubes depresses the cam and causes its clutch to engage the shaft to the starting lever. Then, when the hoist door is closed on that projectile, the shaft is turned, actuating the starting valve.

At the top of the hoist, a projectile-interlock cam protrudes into each tube. If a projectile is at the top of the hoist, the cam will be depressed, positioning the interlock valve in neutral, so that the power

NOTE - ARROWS INDICATE DIRECTION OF ROTATION TO INCREASE FUZE SETTING TIME.

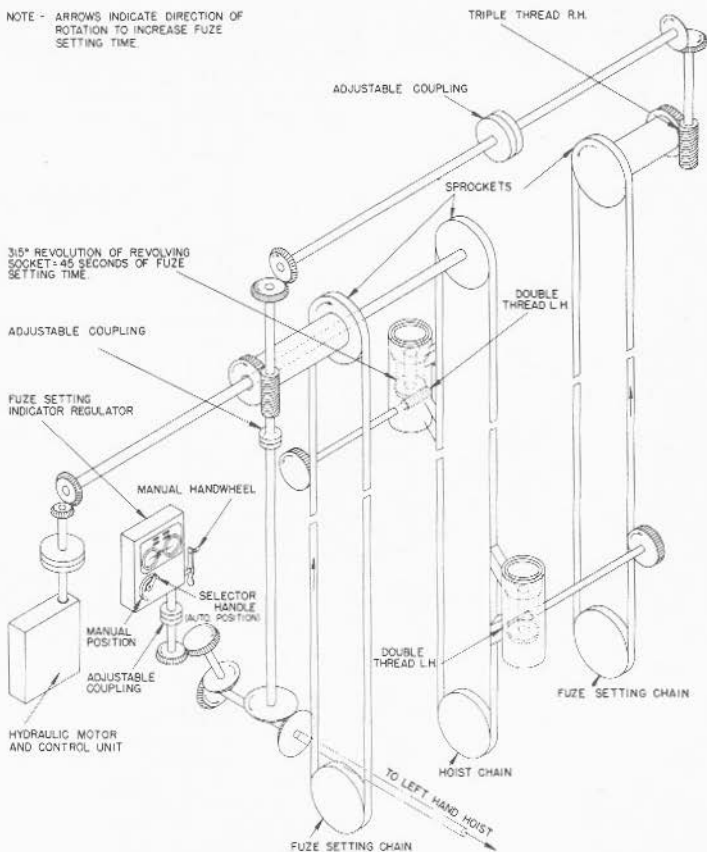

FIGURE 8B18.—5''/38 projectile hoist. Hoisting and fuze-setting gear. (Schematic.)

drive cannot hoist. The doors at the top of the hoist are also equipped with interlock cams. When either door is open, its cam acts to prevent hoisting.

The control cam and interlock cams thus provide safety features which will prevent the power drive from functioning:

1. When the projectile is being placed in the hoist.
2. When the loaded flight reaches the top position.
3. While the projectile is being removed from the hoist.

Assume that a projectile is in its flight at the top of the hoist and that the other flight is empty and at the bottom of the hoist. With the projectile-interlock cam at the top depressed, the hydraulic unit is maintained in neutral. Now a projectile is manually loaded in the other tube and the lower door is closed. The depressed control cam and the closed door actuate the starting valve, but the interlock valve prevents a hoisting cycle. The projectile at the top is then manually removed. This removal of the projec-



tile frees the interlock cam and forces the upper door open. As long as the door is open, the door interlock cam prevents hoisting. When the projectile clears the door, the door snaps closed under spring pressure, and the door interlock is released. The hydraulic motor drives, the projectile rises, and the empty flight goes down. As the projectile reaches the top of the hoist, the interlock cam is depressed, placing the hydraulic controls in neutral. The above cycle will continue as long as shells are loaded and removed. A handwheel, geared to the power-drive output shaft through a clutch, provides an auxiliary manual drive to be used in case of power failure.

Projectiles are manually loaded and removed from the hoist. Manually operated upper and lower projectile-ejector mechanisms facilitate removal. This type of hoist furnishes the gun mount with a rapid, continuous supply of projectiles.

The fuze-setting mechanism consists of (1) a fuze-setting indicator-regulator, (2) fuze-setter chains, and (3) projectile flights. These three components, shown schematically in figure 8B18, are called *regulator*, *fuze chains*, and *flights* in the following discussion.

The regulator is a device which sets the fuze by controlling the position of the fuze chains. It is mounted at an angle on the carriage inboard of the right gun. The regulator can be set for either manual or automatic control by means of a selector lever.

In *manual* control, the gun-crew fuze setter turns

the *manual handwheel* to actuate the chain-setting drive, and the time setting is effected by one of the following methods:

1. By matching pointers, in which case the fuze setter matches pointers on 2 sets of regulator dials, one set of which is actuated by electrical signals from the computer in the director system, and the other set by rotation of the manual handwheel.

2. By setting the desired fuze time on the regulator dials, in which case the manual handwheel is turned until the dials indicate the fuze time opposite fixed index marks. This method is used when the computer is disconnected from the regulator.

In *automatic* control, the manual handwheel is disengaged, and the fuze chains are automatically positioned by an electric power drive in the regulator. The power drive is controlled by electrical signals from the computer. The gun-crew fuze setter has no control over the regulator in automatic control.

A flight consists essentially of an *outer socket* attached to the hoist chain, and an *inner socket* so mounted on ball bearings that it can rotate within the outer socket. (Fig. 8B20, left.) The inner socket is geared to a *sprocket* which engages the fuze chain. The fuze chains are endless chains mounted on the outboard sides of the hoist chain.

A fuze is set by rotating the *time-ring lug* (fig. 8B20, right). The projectile must be placed on the hoist with the fuze *fixed lug* in the V-slot to obtain correct settings. The initial fuze setting is *SAFE*, and

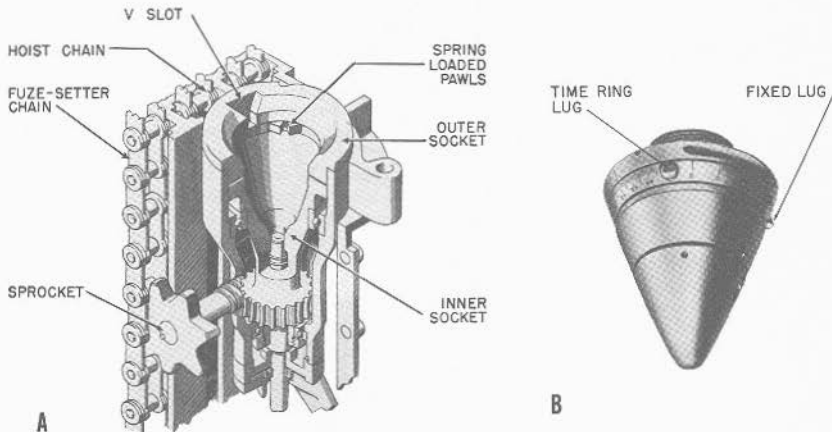

FIGURE 8B20.—Fuze-setting mechanism, 5<sup>1</sup>/<sub>8</sub> caliber gun. A. Projectile flight. B. Fuze.

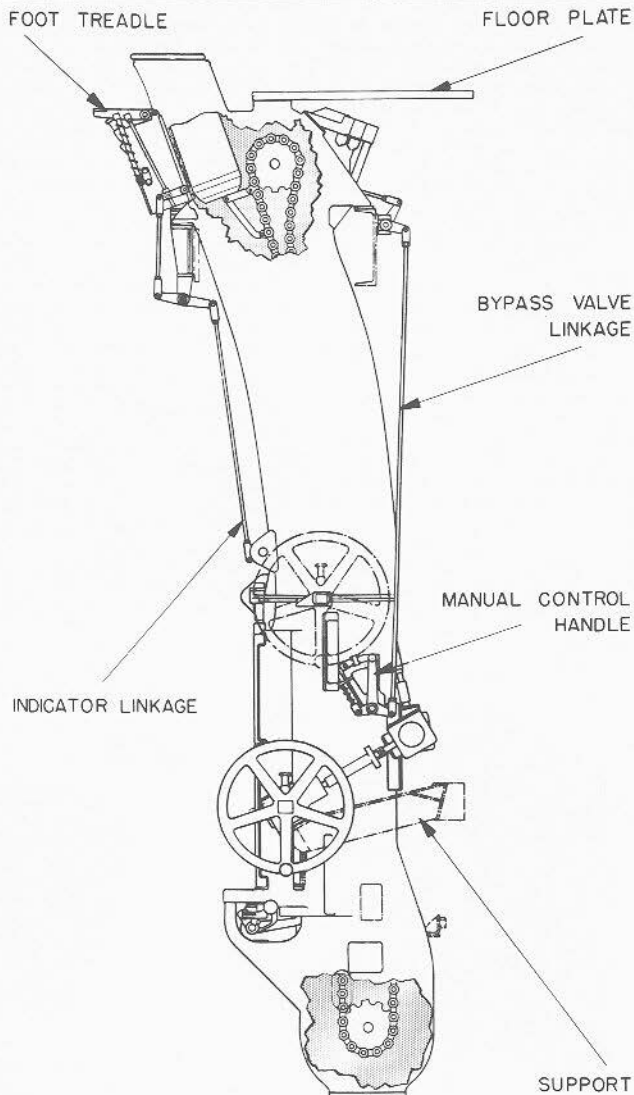

FIGURE 8B21.—Endless-chain powder hoist.

during the fuze-setting operation the time ring is rotated from the maximum time setting *down* to the setting required.

The pawls on the inner socket will engage the time-ring lug when these parts are in alignment. Further rotation of the socket, after engagement, sets the fuze. During hoisting, the point in the flight travel at which engagement does take place depends upon the fuze setting desired.

The sprocket transmits fuze-setting adjustment from the fuze chain to the time fuze in the following ways:

1. By movement of the flight with respect to the fuze chain when the projectile is hoisted. The gearing is so arranged that movement of the flight from the lower to the upper position causes the inner socket to rotate almost exactly one revolution in a direction to *reduce* the time setting on the fuze. A rotation of  $315^\circ$  is equivalent to 45 seconds fuze-setting time.

2. By movement of the fuze chain. This is controlled by the regulator.

From the above discussion it is apparent that if a high fuze setting is desired, the regulator must so position the fuze chain that the pawls will engage the time-ring lug late in the hoisting cycle. The time ring will then be turned a small amount during the remainder of the flight travel and the setting will be high. On the other hand, the pawls are positioned for early engagement in making low fuze settings. Thus, in obtaining a given fuze setting, it is only necessary to make the setting on the regulator which positions the fuze chain, and then hoist the projectile.

Changes in fuze setting may be introduced at any time while the projectile is in the hoist by changing the setting on the regulator. The fuze will be set for the time indicated by the regulator when the projectile is lifted out of the flight, even though it has remained at the delivery end of the hoist for some time.

Projectiles without mechanical time fuzes, such as VT-fuzed or target projectiles, can be hoisted by this equipment. Such projectiles may even be hoisted interspaced with mechanical time fuze ammunition, if so desired, for, having no fuze lugs, the VT-fuzed or target projectiles are unaffected by the fuze-setting mechanism of the hoist. Such a situation occurs in AA firing when mechanical time fuzes are fired interspaced with VT fuzes to aid in spotting the burst onto the target.

#### 8B25. Powder hoist

The twin mount is equipped with right and left hoists of similar design (fig. 8B21). They are semi-automatic endless-chain, enclosed, single-tube hoists with electric-hydraulic drive. A manual drive is pro-

vided for emergency use. Figure 8B21 shows the upper hoist location.

Each hoist is driven and controlled by an electric-hydraulic drive. This drive consists of an electric motor, pump, and tank unit connected by piping to a hydraulic motor and control unit.

The hydraulic motor is geared to a chain-driving sprocket in the upper end of the hoist. An idler sprocket is mounted in the lower end. A conveyor chain, provided with five flights uniformly spaced, is held between the sprockets. It is reversible, for hoisting or lowering powder cases. A HOIST-STOP-LOWER hand-operated control lever, connected to the hydraulic control unit, regulates the direction of motion.

The control gear (fig. 8B22), linked to the hydraulic control unit, is similar to that of the projectile hoist. This control equipment regulates the hoisting and lowering limit of each flight supporting a powder case, and prevents hoisting or lowering when it is unsafe. A handwheel, geared to the power-drive output shaft through a clutch, provides an auxiliary drive to be used in case of power failure.

Cases are manually loaded and removed from the hoist, and the hoist furnishes the gun mount with a rapid, continuous supply of powder cases.

#### 8B26. Sights and sight assembly

Movable prism-type telescopes are mounted at the pointer's, checker's, and trainer's stations. Figure 8B23 shows the location of the telescopes and the sight setter's indicator. The telescopes are located within hooded sight ports which project through the side shield plates.

The elevating prisms in the three telescopes are all moved simultaneously by a system of interconnecting shafts and gears in response to rotation of the sight-angle handcrank. Similarly, all the deflection prisms are positioned by the deflection handcrank. Since the telescopes are mounted on the carriage instead of the slide, the elevating prisms must be rotated by the elevating gear, as the gun elevates, to maintain the vertical angle which has been set between the LOS and axis of the bore. In deflection setting, however, since both the sight and guns move together as the mount is trained, the lateral angle between the telescope and axis of the bore is maintained, once it has been set. Adjustable couplings in the shafting provide for independent adjustment of any one of the telescopes or the indicator dials.

The sight setter's indicator has 2 sight-angle dials (1 high-speed and 1 low-speed), 2 deflection dials (1 high-speed and 1 low-speed), and a range dial as shown in figure 8B24. The sight-angle and de-

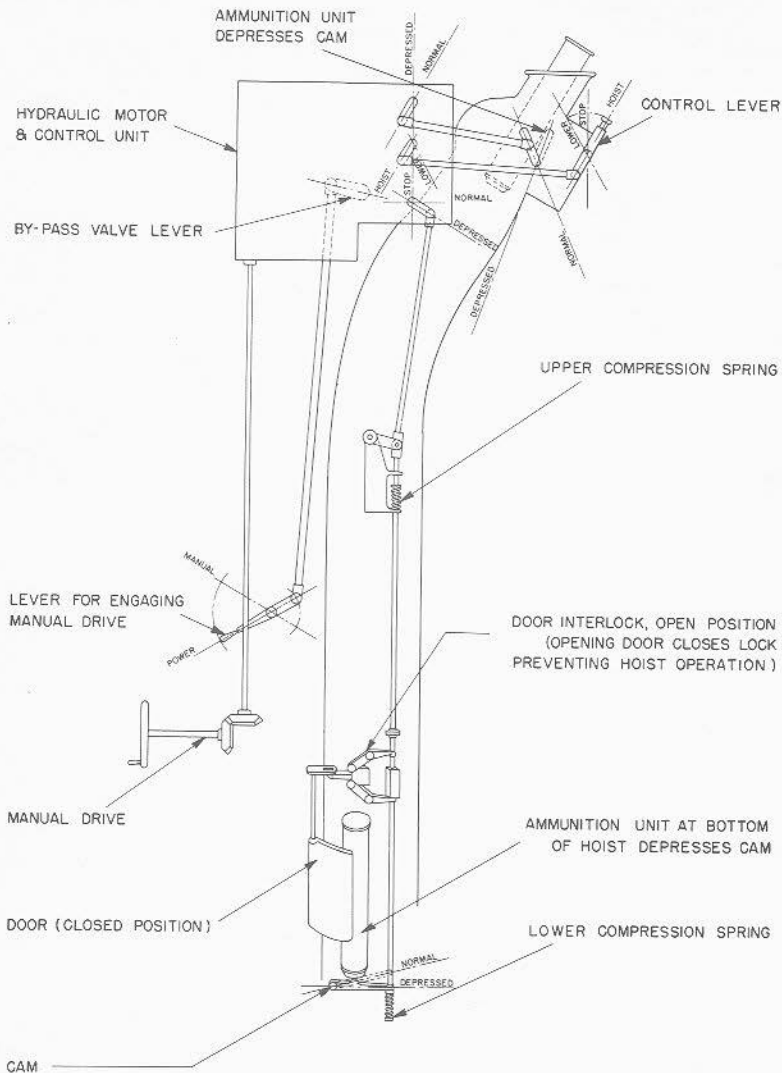

FIGURE 8B22.—5 1/8 caliber powder hoist, hydraulic system control.

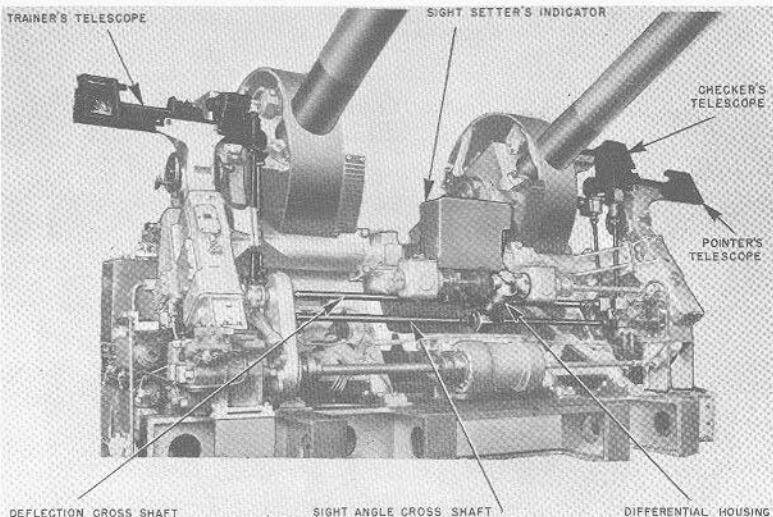

FIGURE 8B23.—Sights in 5"/38 twin mount.

deflection dials consist of two dials each; an inner dial is electrically operated from the computer. The inner dials have a position index mark, but no graduated scale. The sight-angle high-speed outer-ring dial is graduated in minutes of arc, and the low-speed outer dial in 100 minutes of arc. The deflection high-speed outer-ring dial is graduated every mil, and the low-speed outer dial every 100 mils. The outer sight-angle and deflection ring dials are operated by the sight-angle and the deflection handcranks. The range dial is geared to the sight-angle handcrank and has spiral graduations every 100 yards, with readings increasing inwards radially in a clockwise direction. When the dials are at zero position in deflection and elevation, the index of each of the dials matches a fixed index. Sights are set by the sight setter in one of two ways. If the computer is furnishing sight angle and deflection electrically, the proper setting is obtained by turning the handwheels until index marks on the outer ring dials match with the index marks on the inner dials which are positioned by the computer. If sight angle and deflection are received by voice transmission, the handwheels are turned until

the ring dials show the desired settings opposite the fixed pointers. In the latter method, the sight-angle settings desired might be expressed in yards, and this setting would then be made on the range dial.

Since the telescopes are mounted on the carriage instead of the slide, the elevating prisms are rotated as the gun elevates as well as by changing sight-angle inputs. The two variable quantities, gun elevation order and sight angle, are combined in a differential to produce this effect. The net result keeps the vertical angle between the line of sight and the axis of the bore in agreement with the angle set on the sight-angle dials for any position of the gun in elevation.

#### 8B27. Types of mounts and shields

There are four main types of 5"/38 mount assemblies:

1. Enclosed twin mount with ammunition-handling room beneath the mount. The type of mount is the standard installation on battleships, cruisers, and destroyers. It is also used on the island (starboard) side of *Essex* class aircraft carriers. This is the type with which this chapter has been concerned up to now.

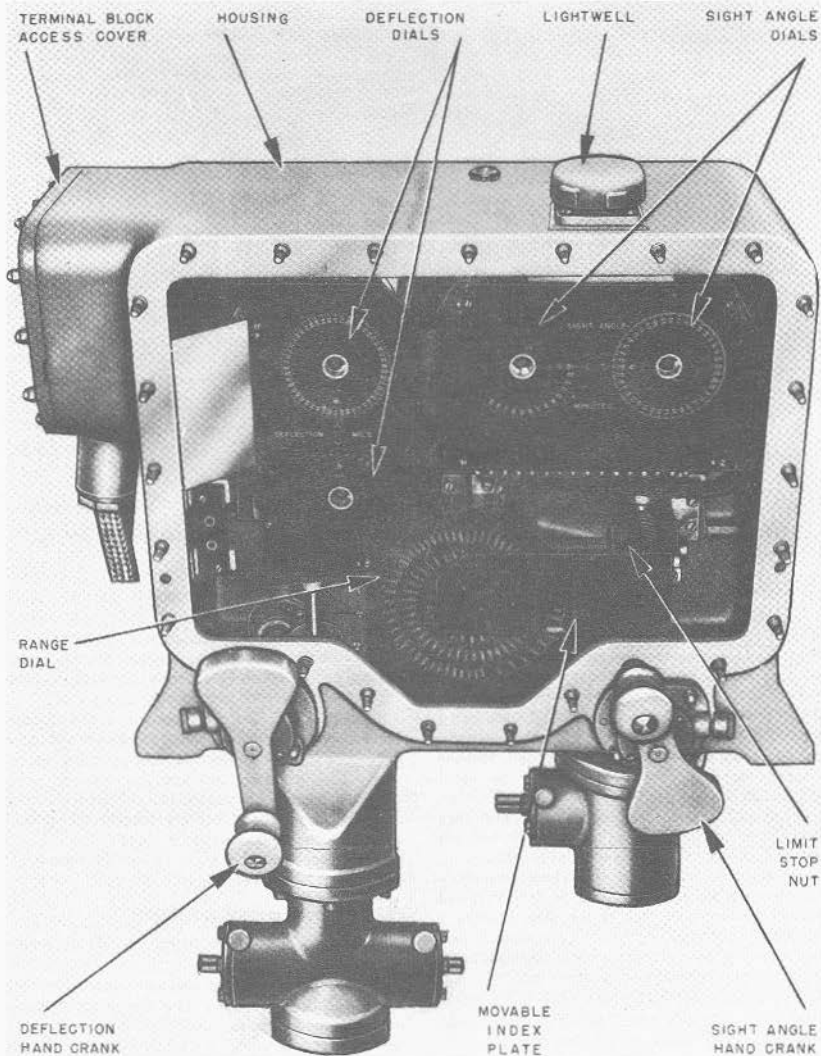

FIGURE 8B24.—Sight setter's indicator on 5 1/8 twin mount. (Front plate of indicator removed.)

2. Enclosed single mount with ammunition-handling room beneath the mount. The enclosed single mount is the old standard destroyer-type mount. It is now found on the many mincraft and auxiliaries which have been developed from the older classes of destroyers, as well as on most of the destroyer escorts in the Fleet and many large auxiliaries (repair ships, destroyer tenders, etc.).

3. Open single mount with ammunition-handling room beneath the mount. This mount was specially developed for installation in the walkways on the port side of aircraft carriers. It is also occasionally found on auxiliary vessels.

4. Open single mount without ammunition-handling room. Mounts of this type can be installed on ships without extensive reconstruction. For that reason it is a type of installation frequently used on converted vessels originally of merchant types. There are no ammunition hoists associated with this mount.

#### **8B28. Other characteristics of 5"/38 caliber twin mounts**

All twin mounts are enclosed in a shield of armor plate which varies in thickness from  $\frac{1}{4}$  inch on destroyers to  $2\frac{1}{2}$  inches on battleships. The shield is a box-like structure about  $15\frac{1}{2}$  feet long, 15 feet wide, and  $10\frac{1}{2}$  feet high. It provides weather, blast, and splinter protection for the crew.

There are doors on both right and left sides near the after end, through which the operating personnel enter or leave the gun room. Other doors and access cover plates are provided to make the operating mechanisms more accessible for inspection and repair. Two identical openings in the front plates provide gun ports. The case-ejector chutes lead to doors in the rear plate of the shield. A roof hatch is located near the after end of the gun mount. Where mount location renders it necessary, this hatch is equipped with a blast hood or shield. Sight hoods mounted on the side shield plates provide protective covering for the three telescopes. The hoods are fitted with hinged shutters and handcranks, so that they can be opened and closed from the inside. A ventilation system installed in the gun room supplies air to various parts of the mount and handling room.

All twin mounts are equipped with various types of electrical power installations.

All power motors have associated controllers and push-button arrangements to start and stop them. The power equipment also includes electric heaters for warming the gun room and the hydraulic equipment.

Illumination in the gun and handling room is supplied by the ship's general illumination circuit. This circuit also includes outlets for (1) battle lanterns, (2) window-wiper motors attached to each telescope, and (3) the battle illumination transformer.

The battle illumination system provides illumination by small lamps at all instruments and controls, such as telescopes, dials, each gun breech, and the bottoms of the projectile hoists.

The mount is provided with two sources of electricity for firing the guns: (1) a motor-generator (ship's power supply), and (2) a 6-volt battery located in the mount handling room. A selector switch mounted near the pointer's station controls the source. The firing circuit provides for electrical firing either locally or from a remote station.

Gun-elevation, gun-train, fuze-setting, and sight-setting electrical signals are supplied to the indicator-regulators and the sight setter's indicator in the mount by fire control circuits from the computer.

The communications facilities for the twin mount include (1) a voice tube between gun room and upper handling room, (2) an automatic telephone which is part of the ship's general communications system, (3) a battle telephone system (sound-powered telephone circuits) between mount and fire control stations, (4) an auxiliary sound-powered telephone circuit with call bell between the mount and the lower ammunition-handling room, and (5) a powerful loud-speaker which is connected to the director and plotting room.

Approximately 27 men are required to man all stations in the mount and the upper handling room. Additional personnel in the lower handling room and magazines are required when fire is to be sustained for considerable periods.

#### **8B29. 5"/38 caliber single mounts**

Aside from the number of guns installed, there are four significant differences between the various 5"/38 caliber single mount assemblies and the 5"/38 caliber twin mount assembly. These differences are in (1) the rammer, (2) the sight mechanism, (3) the power drive, and (4) the ammunition-handling arrangements.

The rammer on the 5"/38 caliber single mount is not equipped with the 2 to 1 gear ratio arrangement described in article 8B19. The rammer piston travels the same distance in its cylinder that the crosshead and spade move during the ramming stroke.

Although final results are the same, sights on single mounts are different in design from those on the twins. There is no differential for adding gun elevation and

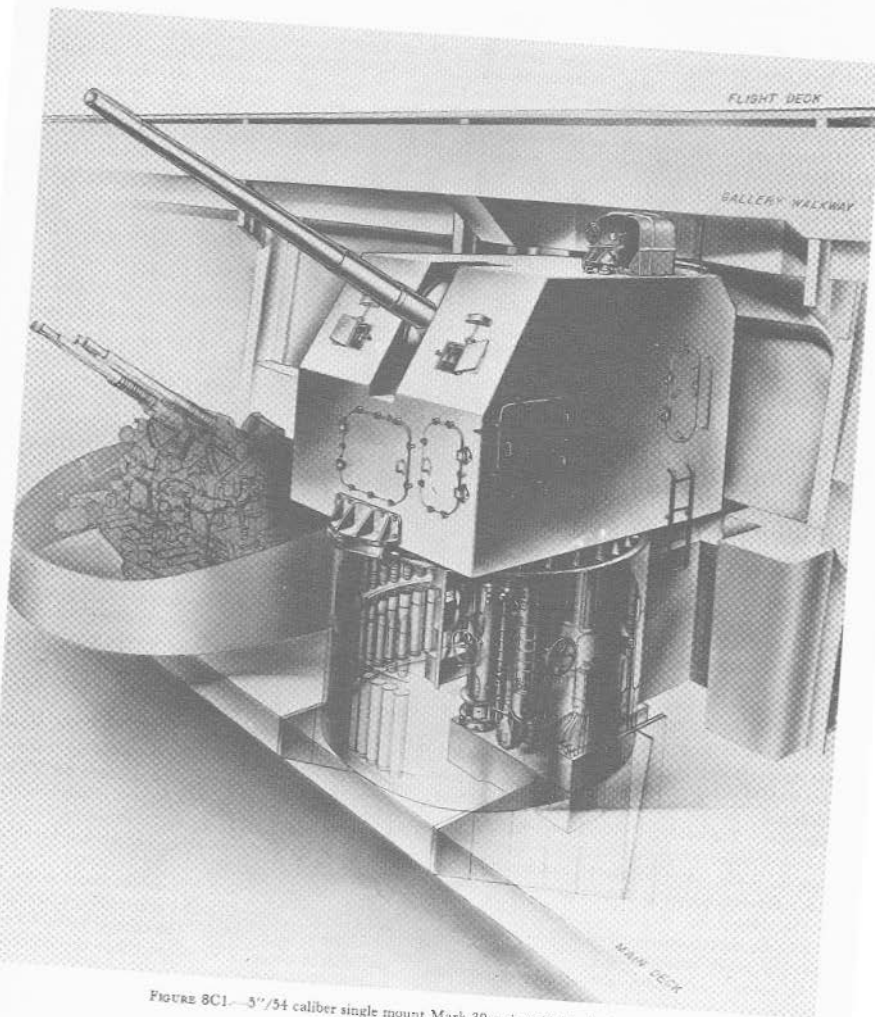

FIGURE 8C1.—3"/54 caliber single mount Mark 39 as installed in *Midway* class.

sight angle. Instead, the linkages to the sight prisms on enclosed single mounts are driven by a large sight driving gear inside the large circular housing next to the slide. This gear in turn is driven by a banjo-shaped assembly which moves in elevation with the slide. In the banjo are a worm and worm gear mechanically connected to the sight angle crank. Turning the crank causes this gear train to rotate a pinion meshed with the sight driving gear, which in turn positions the sight prisms.

Sights on single open mounts are in general similar to those on single enclosed mounts, except on open mounts not equipped with movable-prism telescopes. On such mounts, the mechanical linkage briefly described above positions the pads on which the sight telescopes are mounted.

### C. Five-Inch 54-Caliber Assembly

#### 8C1. General

The 5"/54 mount Mark 39 is an enclosed, dual-purpose, semiautomatic, rapid-fire, tray-loading, base-ring type single gun mount. It is a mount resembling the 5"/38 caliber single enclosed mount. It differs, however, from that basic type in its elevation and train power drives, and its ammunition service. And its sights are like those of 5"/38 twin mounts.

#### 8C2. Design development

The 5"/54 caliber mount, shown in figure 8C1, is a design developed primarily for the USS *Midway* class carriers. It will also be installed on certain other new-construction vessels. Installations on each *Midway* class ship consist of 9 port and 9 starboard mounts, placed outboard below the level of the flight deck.

The mounts are supported on cylindrical foundation bulkheads similar to turret foundations. These foundations are structurally supported on sponsons extending from the ship's hull, with sponson platforms mounted flush with the main deck. The foundation bulkhead forms the upper ammunition-handling room enclosure.

#### 8C3. Mount arrangement

The general design (see figs. 8C2 and 8C3) and functional arrangement of the 5"/54 caliber gun and mount are patterned after the 5"/38 caliber single and twin enclosed mounts.

Several different types of power drive are used with single mounts, depending upon the type of mount and the ship upon which installed. On ships which are equipped with fire control installations the drives are such as to provide for automatic control, local control, and manual control. On many converted merchant ships only local and manual controls are available.

The 5"/38 caliber single mounts of the handling-room type are equipped with projectile hoists of the same type as used in twin mounts. There are, however, no powder hoists. Powder is passed from the upper handling room to the gun room through a scuttle. Mounts of other than the handling-room type are not equipped with hoists, but do have a fuze setter located outboard of the projectile man's station.

This mount has an enclosed gun room arrangement with shield, gun, slide, and hoists mounted on a base-ring type carriage above an ammunition-handling room. The carriage is supported and rotates on bearings on a conventional stand. Carriage and gun are arranged for empty-case ejection from the gun through chute and doors in the carriage overhang to the main deck level of the sponson. Gun room and handling room are weather-sealed and power-ventilated.

#### 8C4. Elevating and training gears

The power drives for elevating the gun and training the mount are separate high-speed all-electric amplidyne units (chapter 10 discusses the operation of amplidyne units) controlled by electric signals either from a remote computer (when in automatic) or from the local handwheel stations. The elevating and training gears are equipped for auxiliary manual drive. The elevating and training power-drive generating equipment is remotely located in the ship at the second platform. The limits of gun laying motion are from 10° depression to 85° elevation, with a maximum train of 190°.

#### 8C5. Ammunition

This gun uses semifixed ammunition consisting of a 70-pound projectile and a case assembly weighing 32 pounds. The powder charge itself weighs 18

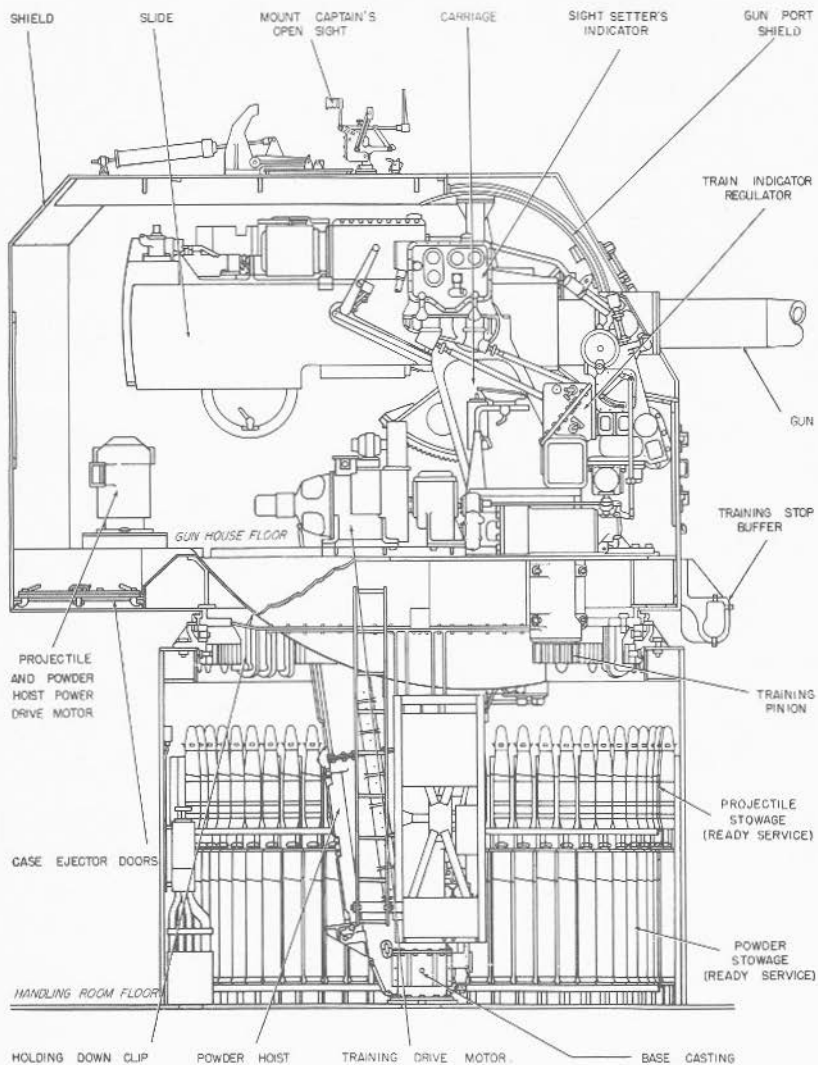

FIGURE 8C2.—5"/51 caliber mount—right side, longitudinal section.

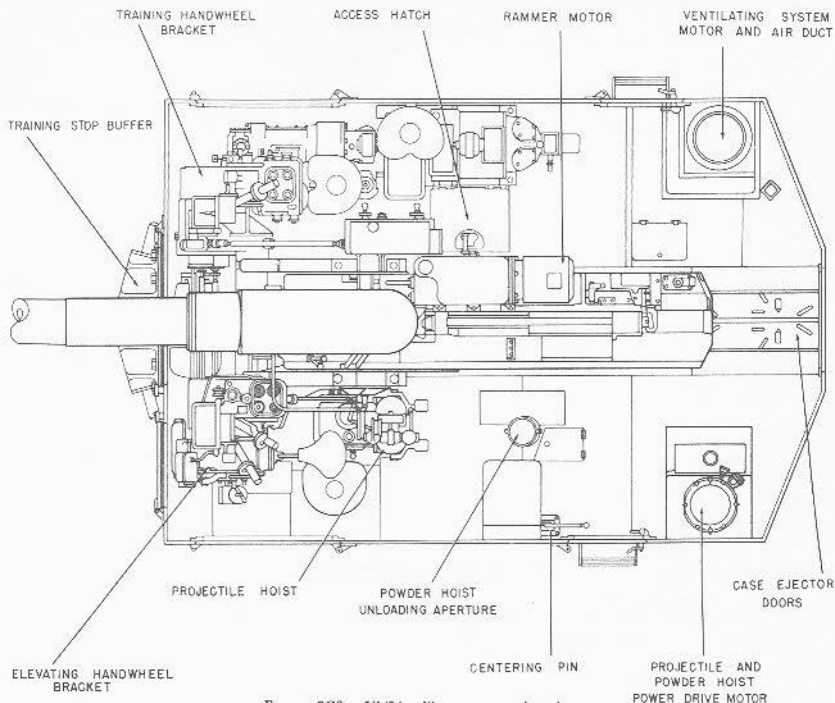

FIGURE 8C3.—5"/54 caliber mount—plan view.

pounds. The gun and its crew are capable of a sustained firing rate of about 15 to 18 rounds per minute.

#### 8C6. Ballistic data

The mount is designed for use against surface and airborne targets. The gun has a horizontal range of about 26,000 yards and a maximum vertical range of

49,000 feet. Initial velocity of service rounds is 2,650 feet per second.

#### 8C7. Personnel

A minimum crew of 16 men, 10 for the gun room and 6 for the handling room, is required for ammunition service, gun loading, gun laying, and sight operations.